

DESCRIPTION

Add stylish, contemporary lighting with minimal effort with these 1x1 surface mount LED panels. Unlike traditional LED panels that require a grid ceiling, these fixtures mount directly to dry wall ceilings.

FEATURES

- Edge-lit design allows for an overall slimmer design that eases the installation process and modernizes the space
- Total depth of only 0.98-inches; includes the driver box
- 0-10V dimming

LISTINGS

- UL rated for damp locations

PERFORMANCE

- CRI: 80
- CCT: 4000K or 5000K
- LED L70 Life Hours: 50,000

THERMAL

- -4°F to 104°F (-20°C to 40°C) operating temperature

ELECTRICAL

- THD: <20%
- Power Factor: >0.9
- Input Voltage: 120-277V
- Surge Protection: 1kV
- Dimmable power supply (0-10V)

INSTALLATION

- Designed for surface mounting (mounting accessories included); See installation instructions for more information on how to install these fixtures.

CONSTRUCTION

- Aluminum housing with white or black finish
- PMMA lens protects LEDs while evenly distributing light

Project name	Type
Catalog number	
Comments	Voltage
Approved by	Date



WARRANTY

- 5-year limited warranty; see pltsolutions.com for warranty details

APPLICATIONS

- Offices
- Hallways
- Classrooms
- Multipurpose Areas
- Conference Rooms

PERFORMANCE SUMMARY

Item #	Size	Watts	Lumens	LPW	CCT	CRI	Dimming	Voltage	Finish
PLT-90463	1x1	18	1888	105	4000K	80	0-10V	120-277V	White
PLT-90464	1x1	18	1942	108	5000K	80	0-10V	120-277V	White
PLT-90465	1x1	18	1834	102	4000K	80	0-10V	120-277V	Black
PLT-90466	1x1	18	1887	105	5000K	80	0-10V	120-277V	Black

DIMENSIONS

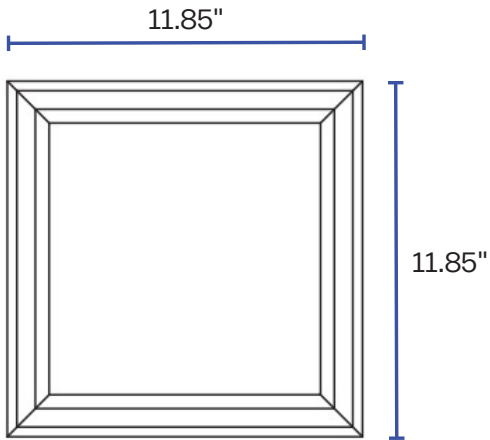

DIMENSIONS

Length: 11.85"
 Height: 0.98"
 Width: 11.85"
 Weight: 1.09 lbs

