



## LED T5 TYPE B TUBES

### WARNING, CAUTION, SAFETY AND INSTALLATION INSTRUCTIONS

#### WARNING

- Installation, service, and maintenance of luminaries should be performed by a qualified licensed electrician.
- Follow these instructions and notes to ensure that the product is installed and operated in a safe condition.
- There are tubes, operation instructions, and field applied double-ended or single-ended applications labels in this retrofit kit.

#### CAUTION

- Do not make or alter any holes in the wiring enclosure or electrical components during installation.
- Type B Lamp – intended for operation in luminaries with traditional fluorescent-type lamp holders wired directly to the branch circuit. This includes both factory-wired luminaries as well as those converted for this purpose under a retrofit program.
- Not for emergency lighting.
- Installers should not disconnect existing wires from the lamp holder terminals to make new connections at the lamp holder terminals. Instead, installers should cut existing lamp holder leads away from the lamp holder and wire new electrical connections to the lamp holder lead wires by employing applicable connectors.
- Install this kit only in the luminaires that have the construction features and dimensions shown in the photography and/or drawings and where the input rating of the retrofit kit does not exceed the input rating of the luminaire.
- To avoid a potential fire or shock hazard, do not use this retrofit kit in luminaires employing shunted bi-pin lampholders. NOTE: Shunted lamp holders are found only in fluorescent luminaires with Instant-start ballasts. Instant-start ballasts can be identified by the words “Instant Start” or “I.S.” marked on the ballast. This designation may be in the form of a statement pertaining to the ballast itself, or may be combined with the marking for the lamps with what the ballast is intended to be used, for example F40T12/IS. For more information, contact the LED luminaire retrofit kit manufacturer.
- THIS RETROFIT KIT IS ACCEPTED AS A COMPONENT OF A LUMINARIE WHERE THE SUITABILITY OF THE COMBINATION SHALL BE DETERMINED BY AUTHORITIES HAVING JURISDICTION.
- LED Retrofit Kit installation requires knowledge of luminaires electrical systems. If not qualified, do not attempt installation. Contact a qualified electrician.
- Only use the control provided with or specified by these instructions to control this lamp. This lamp will not operate properly when connected to a standard (incandescent) dimmer or dimmer control. Only operate with specific dimmer PLTSPA manufactured by PLT Solutions.
- The units covered by this report were intended to retrofit surface mount, Type IC or non-IC recessed mount Listed fluorescent luminaries that use a maximum of four tubular lamps. The minimum lamp compartment dimensions are listed below:

Model Number	Minimum Lamp Compartment Dimensions [Length x Width x Height] [in]	Lamp Quantity
PLTSPN122 / PLTSPN123 PLTSPN124 / PLTSPN125 PLTSPN222 / PLTSPN223 PLTSPN224 / PLTSPN225	36.2 x 22.4 x 2.95	4
PLTSPH122 / PLTSPH123 PLTSPH124 / PLTSPH125 PLTSPH222 / PLTSPH223 PLTSPH224 / PLTSPH225	23.2 x 12.99 x 2.36	4



## Wiring Diagrams

### Single-ended Wiring Instructions

The below ballast wiring represents typical configurations. The actual ballast wiring varies according to ballast model. The socket should be non-shunted.

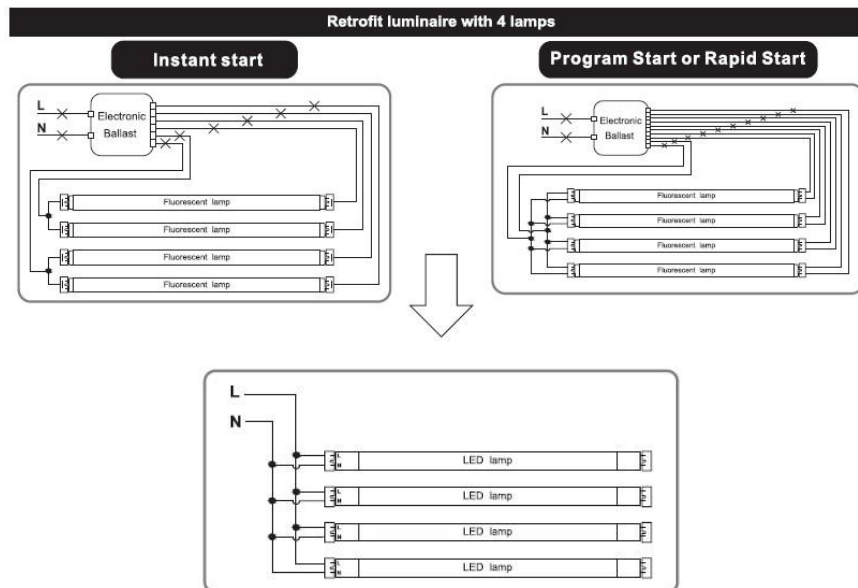
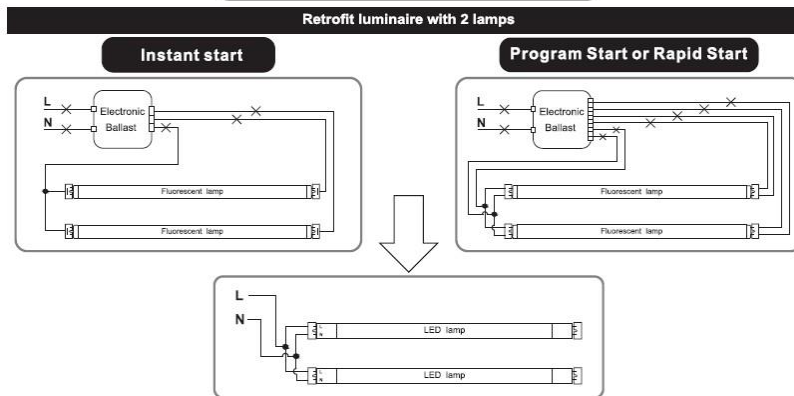
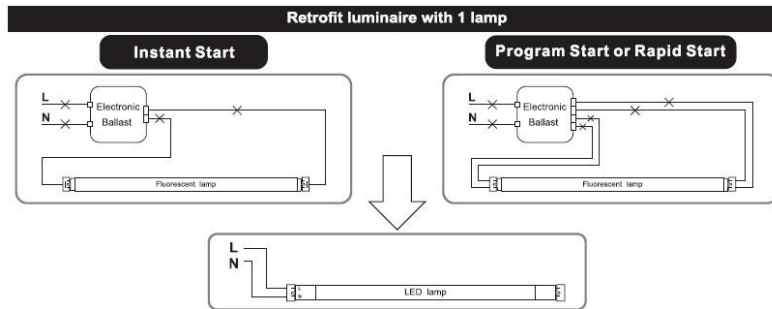



# LED T5 TYPE B TUBES

## WARNING, CAUTION, SAFETY AND INSTALLATION INSTRUCTIONS

### Double-ended Wiring Instructions

The bellow ballast wiring represents typical configurations. The actual ballast wiring varies according to the ballast model. If the sockets are in good conditions, you do not need to change them to change them, regardless of the type. Make sure one side of the fixture is connected to Live (L) and the other side to Neutral (N).

#### Retrofit luminaire with 1 lamp

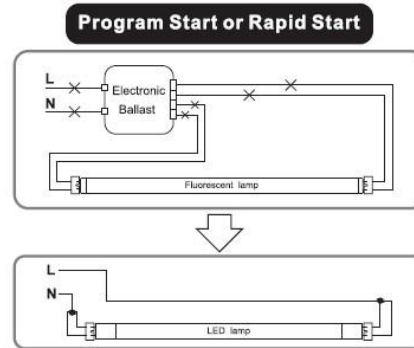
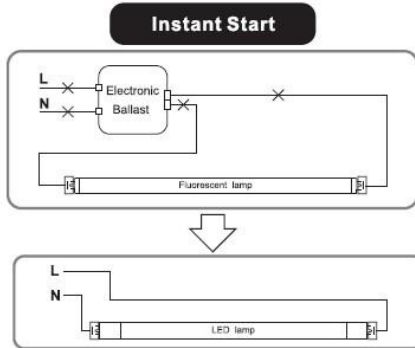

#### Retrofit luminaire with 2 lamps

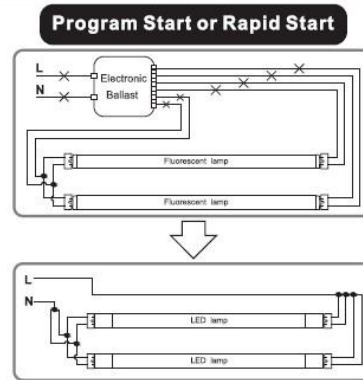
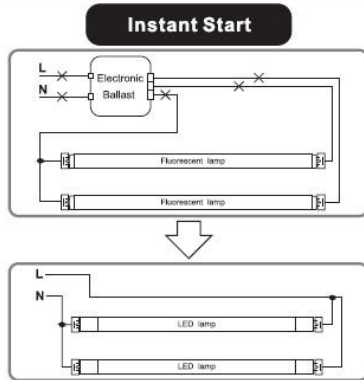

#### Retrofit luminaire with 4 lamps

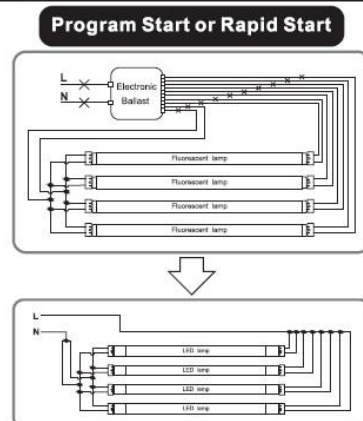
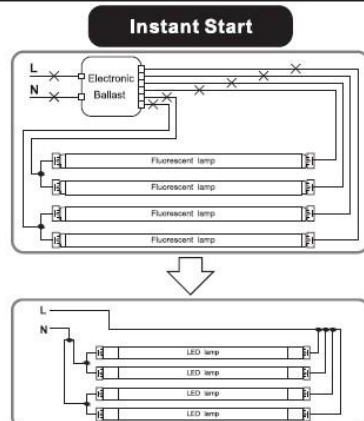



## FCC Warning

- This device complies with Part 15 of the FCC Rules. Operation is subject to the following two conditions: (1) this device may not cause harmful interference, and (2) this device must accept any interference received, including interference that may cause undesired operation.

## **⚠ WARNING**

- Before installing, servicing, or performing routine maintenance upon this equipment, follow these general precautions.
- To reduce the risk of death, personal injury, or property damage from fire, electric shock, falling parts, cuts/abrasions, and other hazards, read all warnings and instructions included with and on the fixture box and all fixture labels.
- Proper grounding is required to ensure safety.
- Power must be turned off at the breaker before installation or maintenance.
- This product must be installed in accordance with the applicable installation code by a person familiar with the construction and operation of the product and the hazards involved.
- Wear gloves and eye protection at all times while installing, servicing, or performing maintenance on the luminaire, and avoid direct eye exposure to the light source while it is on.
- To prevent wiring damage or abrasion, do not expose wiring to edges of sheet metal or other sharp objects.
- Do not install damaged product. Inspect luminaire for damage that may have occurred during transit. If damaged, contact the manufacturer immediately.
- These instructions do not purport to cover all details or variations in equipment nor to provide every possible contingency to meet in connection with installation, operation, or maintenance. Should further information be desired or should particular problems arise which are not covered sufficiently for the purchaser's or owner's purposes, contact the manufacturer.

## **⚠ ADVERTENCIA**

- Antes de instalar, reparar o realizar el mantenimiento de rutina de este equipo, siga estas precauciones generales.
- Para reducir el riesgo de muerte, lesiones personales o daños a la propiedad por fuego, descarga eléctrica, caída de piezas, cortes / abrasiones y otros peligros, lea todas las advertencias y instrucciones incluidas con y en la caja del dispositivo y todas las etiquetas del dispositivo.
- Se requiere una conexión a tierra adecuada para garantizar la seguridad.
- Se debe apagar la energía en el disyuntor antes de la instalación o el mantenimiento.
- Este producto debe ser instalado de acuerdo con el código de instalación aplicable por una persona familiarizada con la construcción y operación del producto y los peligros involucrados.
- Utilice guantes y protección para los ojos en todo momento durante la instalación, el servicio o el mantenimiento de la luminaria, y evite la exposición directa de los ojos a la fuente de luz mientras está encendida.
- Para evitar daños o abrasiones en el cableado, no exponga el cableado a bordes de láminas de metal u otros objetos afilados.
- No instale un producto dañado. Inspeccione la luminaria en busca de daños que puedan haber ocurrido durante el tránsito. Si está dañado, comuníquese con el fabricante de inmediato.



## LED T5 TYPE B TUBES

### WARNING, CAUTION, SAFETY AND INSTALLATION INSTRUCTIONS

- Estas instrucciones no pretenden cubrir todos los detalles o variaciones en el equipo ni proporcionar todas las posibles contingencias a cumplir en relación con la instalación, operación o mantenimiento. Si desea obtener más información o si surgen problemas particulares que no están suficientemente cubiertos para los propósitos del comprador o propietario, comuníquese con el fabricante.