



12" COLOR SELECTABLE LED SURFACE MOUNT DOWNLIGHT W/ EMERGENCY BACKUP

WARNING, CAUTION, SAFETY AND INSTALLATION INSTRUCTIONS

WARNING

- Installation, service, and maintenance of luminaries should be performed by a qualified licensed electrician.

CAUTION

- This fixture must be surface mounted to a junction box or a non-combustible surface at a minimum height of at least 13' (4 meters).

NOTICE

- Tools required: Phillips screwdriver, wire cutters, pliers, wrench
- The installer should prepare necessary accessories and spare parts (not provided), including junction box and screws.

Package Contents

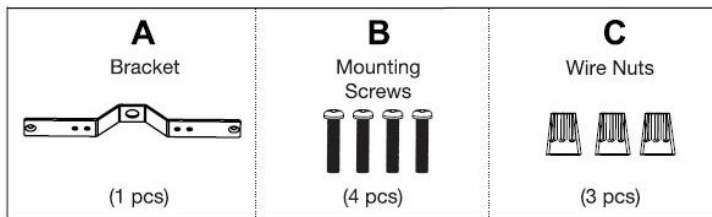

Installation Instructions

1. Turn OFF power at the circuit breaker. Typical junction box wiring has only white & black switched wires controlled by a wall switch for on/off or dimming.

Ensure the junction box has an additional set of UNSWITCHED WIRES (continuous) main power wires available. If necessary, add these wires as shown. Label these additional wires so the correct connections can be made.

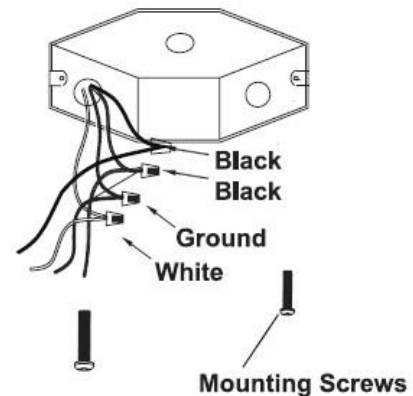



12" COLOR SELECTABLE LED SURFACE MOUNT DOWNLIGHT W/ EMERGENCY BACKUP

WARNING, CAUTION, SAFETY AND INSTALLATION INSTRUCTIONS

2. Screw the emergency backup unit up into the junction box using the 2 x 8/32 screws provided. Then using the wire unit provided, connect the three cables available for connection into the junction box.

For a standard installation:

- a. Connect the "switched line" to the black switched power cable coming from the junction box.
- b. Connect the "continuous main power" from the battery backup box to the continuous main black wire from the junction box.
- c. Connect the "neutral" white wire from the battery backup together with the other two neutral wires from the junction box.

If the fixture is going to be used as 24/7 lighting or just as an emergency light, see Wiring Diagrams for Continuous Power Applications Section and follow instructions.

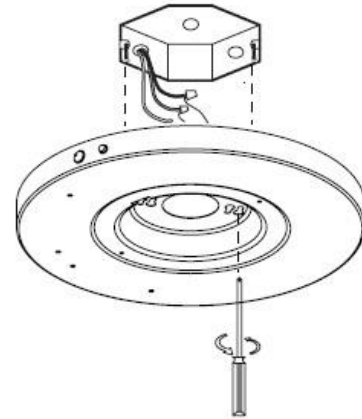

3. Screw the bracket that locks the mounting plate into the emergency backup to the unit using the 2 screws provided.

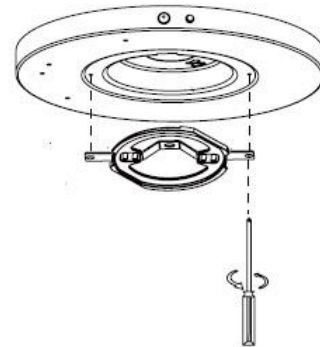

4. Make electrical connections from the LED fixture to the battery backup.
 - a. Use the orange connector already supplied and attached to the unit.
 - b. Be sure to connect the ground wire coming out of the light fixture.
 - c. Move the CCT switch to the desired Kelvin selection before moving on to Step 5.

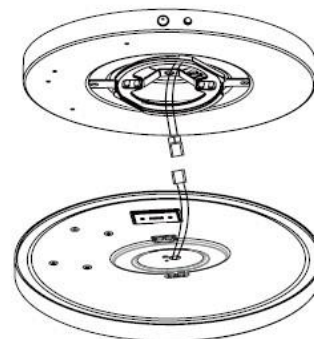



12" COLOR SELECTABLE LED SURFACE MOUNT DOWNLIGHT W/ EMERGENCY BACKUP

WARNING, CAUTION, SAFETY AND INSTALLATION INSTRUCTIONS

5. Feed all wires up into the battery backup box and raise the light fixture up to the ceiling. Align the mounting tabs on the back of the fixture with the indents on the mounting bracket. Using the stickers on the fixture (mounting tab reference point) and on the ceiling bracket as a reference point, lift the fixture up to the emergency backup and rotate clockwise until the fixture is secured (45° turn until it locks into place).

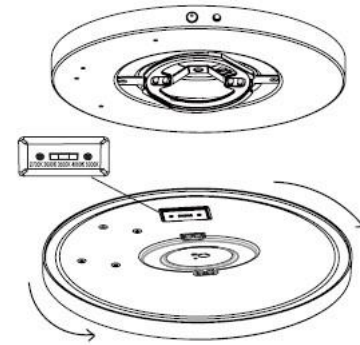

120V Fixture

Wiring Diagrams for Continuous Power Applications

If the battery backup up is used for a system with 24/7 lighting OR as a dedicated emergency light only (light is OFF in normal conditions), only continuous UNSWITCHED power is needed at the junction box. There is no need for switched wires.

Option 1 – as 24/7 lighting

1. Connect the two black wires (labeled as “Continuous Main Power” and “Switched Line”) from the battery backup to the black main wire in the junction box and connect the white (“Neutral”) to the white wire from the box wires.
2. Screw the emergency backup unit up into the junction box using the 2 x 8/32 screw provided, then go to Step 4 of the Installation Instructions.

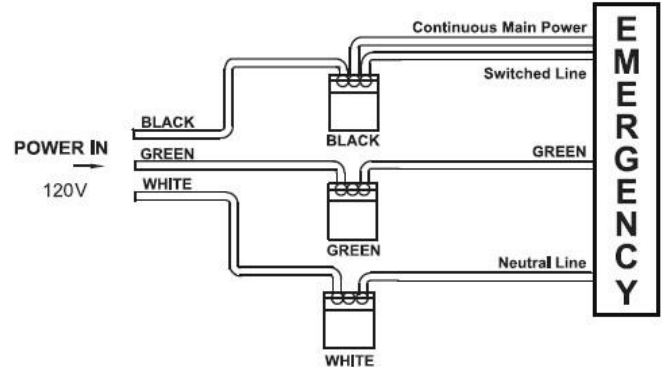

Option 2 – as emergency light only

1. Connect the black wire (labeled as “Continuous Main Power”) from the battery backup to the black main wire in the junction box and connect the white (“Neutral”) to the white wire from the battery backup fixture to the junction box.
2. Screw a wire nut over the “Switched Line” and leave unconnected. Then screw the emergency backup unit up into the junction box using the 2 x 8/32 screws provided, then go to Step 4 of the Installation Instructions.

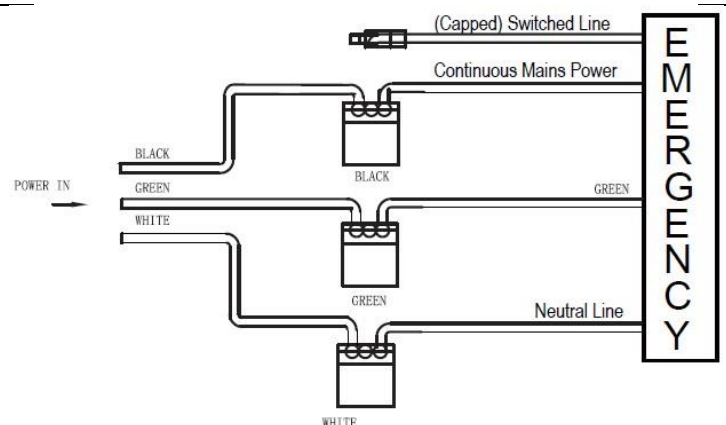



12" COLOR SELECTABLE LED SURFACE MOUNT DOWNLIGHT W/ EMERGENCY BACKUP

WARNING, CAUTION, SAFETY AND INSTALLATION INSTRUCTIONS

Test Button Functions

While main power is on:

- A quick press of the test button (<6 seconds) simulates a “main power outage” or “emergency mode”. The light will turn on and run off battery power.
 - o As the system runs and checks the battery power and circuit connections, the LED indicator light will flash green at 1 cycle/second.
- Pressing the test button for >6 seconds puts the unit into the annual self-check mode, which has a 90-minute run time.
 - o NOTE: The system will completely discharge the battery during this mode. To exit the mode, press the test button.
 - o As the system runs the monthly self-check on the battery and circuit connections, the LED indicator will flash green at 3 cycle/second.

While in emergency mode (during power outage):

- Pressing the test button for <1 second shuts off the unit. Press the test button again to turn it back on.
- Pressing the test button for >6 seconds completely shuts off the emergency output. In this state, the system will not function unless the main power is restored.

LED Indicator Colors & Functions

RED	Battery is charging
GREEN	Battery is fully charged
YELLOW	Check system - Possible battery replacement needed, or system maintenance required
GREEN FLASHING	Monthly or annual test mode is running
OFF	Indicates a power outage. - When battery backup unit in emergency mode, the LED indicator will be OFF.
Minimum Charge Time	24 Hours

⚠ WARNING

- Before installing, servicing, or performing routine maintenance upon this equipment, follow these general precautions.
- To reduce the risk of death, personal injury, or property damage from fire, electric shock, falling parts, cuts/abrasions, and other hazards, read all warnings and instructions included with and on the fixture box and all fixture labels.
- Proper grounding is required to ensure safety.
- Power must be turned off at the breaker before installation or maintenance.
- This product must be installed in accordance with the applicable installation code by a person familiar with the construction and operation of the product and the hazards involved.



12" COLOR SELECTABLE LED SURFACE MOUNT DOWNLIGHT W/ EMERGENCY BACKUP

WARNING, CAUTION, SAFETY AND INSTALLATION INSTRUCTIONS

- Wear gloves and eye protection at all times while installing, servicing, or performing maintenance on the luminaire, and avoid direct eye exposure to the light source while it is on.
- To prevent wiring damage or abrasion, do not expose wiring to edges of sheet metal or other sharp objects.
- Do not install damaged product. Inspect luminaire for damage that may have occurred during transit. If damaged, contact the manufacturer immediately.
- These instructions do not purport to cover all details or variations in equipment nor to provide every possible contingency to meet in connection with installation, operation, or maintenance. Should further information be desired or should particular problems arise which are not covered sufficiently for the purchaser's or owner's purposes, contact the manufacturer.

⚠ ADVERTENCIA

- Antes de instalar, reparar o realizar el mantenimiento de rutina de este equipo, siga estas precauciones generales.
- Para reducir el riesgo de muerte, lesiones personales o daños a la propiedad por fuego, descarga eléctrica, caída de piezas, cortes / abrasiones y otros peligros, lea todas las advertencias y instrucciones incluidas con y en la caja del dispositivo y todas las etiquetas del dispositivo.
- Se requiere una conexión a tierra adecuada para garantizar la seguridad.
- Se debe apagar la energía en el disyuntor antes de la instalación o el mantenimiento.
- Este producto debe ser instalado de acuerdo con el código de instalación aplicable por una persona familiarizada con la construcción y operación del producto y los peligros involucrados.
- Utilice guantes y protección para los ojos en todo momento durante la instalación, el servicio o el mantenimiento de la luminaria, y evite la exposición directa de los ojos a la fuente de luz mientras está encendida.
- Para evitar daños o abrasiones en el cableado, no exponga el cableado a bordes de láminas de metal u otros objetos afilados.
- No instale un producto dañado. Inspeccione la luminaria en busca de daños que puedan haber ocurrido durante el tránsito. Si está dañado, comuníquese con el fabricante de inmediato.
- Estas instrucciones no pretenden cubrir todos los detalles o variaciones en el equipo ni proporcionar todas las posibles contingencias a cumplir en relación con la instalación, operación o mantenimiento. Si desea obtener más información o si surgen problemas particulares que no están suficientemente cubiertos para los propósitos del comprador o propietario, comuníquese con el fabricante.