



## COLOR/WATTAGE SELECTABLE LED T8 U-BEND HYBRID TUBES

### WARNING, CAUTION, SAFETY AND INSTALLATION INSTRUCTIONS

#### WARNING

- Installation, service, and maintenance of luminaires should be performed by a qualified licensed electrician.
- Check lamp before installation. If there is any damage, do not install. If the glass lamp tube is broken, the lamp must be disposed of immediately.
- There are tubes, operation instructions, and field applied double-ended or single-ended labels in this retrofit kit.

#### CAUTION

- Installers should examine all parts that are not intended to be replaced by the retrofit kit for damage and replace any damaged parts prior to installation of the retrofit kit.
- **TYPE A LAMP** – intended for direct substitution of a fluorescent lamp and operation from the integral ballast without any modifications to the fluorescent luminaire.
  - Do not install this lamp in a pre-heat luminaire.
  - This lamp only operates on electronic ballasts. If the lamp does not light when the luminaire is turned on, remove the lamp from the luminaire and contact the manufacturer.
  - If the lamp or luminaire exhibits undesirable operation such as buzzing and flickering, immediately turn off the power, remove the lamp from the fixture, and contact the manufacturer.
  - This product may cause interference to radio equipment and should not be installed near maritime safety communications equipment or other critical navigation or communication equipment operating between 0.45-30 MHz.
- **TYPE B LAMP** – intended for operation in luminaires with traditional fluorescent-type lampholders wired directly to the branch circuit. This includes both factory-wired luminaires as well as this converted for this purpose under a retrofit program.
  - Do not make or alter any holes in the wiring enclosure or components during installation.
  - Installers should not disconnect existing wires from lampholder terminals to make new connections at lampholder terminals. Instead, installers should cut existing lampholder leads away from the lampholder and make new electrical connections to lampholder lead wires by employing applicable connectors.
  - Install this kit only in the luminaires that have the construction features and dimensions shown in the photographs and/or drawings, and where the input rating of the retrofit kits does not exceed the input rating of the luminaire.
  - To avoid potential fire or shock hazard, do not use this retrofit kit in luminaires employing shunted bi-pin lampholders. Instant-start ballasts can be identified by the words “Instant Start” or I.S.” marked on the ballast. This designation may be in the form of a statement pertaining to the ballast itself or may be combined with the marking for the lamps with which the ballast is intended to be used. For example, F40T12/IS.
  - Suitable for use with the following emergency equipment: PRECISION LIGHTING & TRANSFORMER, INC., model PLTSP91, PLTSP92
- **THIS RETROFIT KIT IS ACCEPTED AS A COMPONENT OF A LUMINAIRE WHERE THE SUITABILITY OF THE COMBINATION SHALL BE DETERMINED BY AUTHORITIES HAVING JURISDICTION. PRODUCT MUST BE INSTALLED BY A QUALIFIED ELECTRICIAN IN ACCORDANCE WITH THE APPLICABLE AND APPROPRIATE ELECTRICAL CODES. THE INSTALLATION GUIDE DOES NOT SUPERSEDE LOCAL OR NATIONAL REGULATIONS FOR ELECTRICAL INSTALLATIONS.**



# COLOR/WATTAGE SELECTABLE LED T8 U-BEND HYBRID TUBES

## WARNING, CAUTION, SAFETY AND INSTALLATION INSTRUCTIONS

### NOTICE

- Keep lamps away from flames and high temperatures. Do not place any objects on lamps.
- Clean luminaire with a dry cloth. Do not clean lamps with corrosive chemicals.
- **Minimum Compartment Dimensions** - The units covered by this report were intended to retrofit surface mount, Type IC or non-IC recessed mount listed fluorescent luminaires that use a maximum of 4 tubular lamps. The minimum lamp compartment dimensions are:

<b>Model Number</b>	PLTSPM136	
<b>Min. Lamp Compartment of Luminaire, Overall Dimensions, inch</b>	<b>Length</b>	47.6
	<b>Width</b>	20.9
	<b>Height</b>	3.9
<b>Maximum LED Lamp Quantity in Luminaire</b>	4	

### Installation Instructions

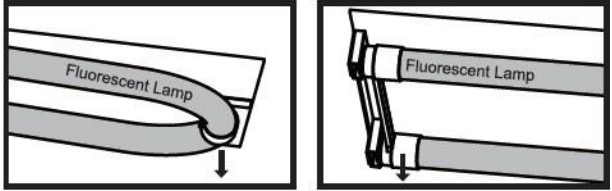
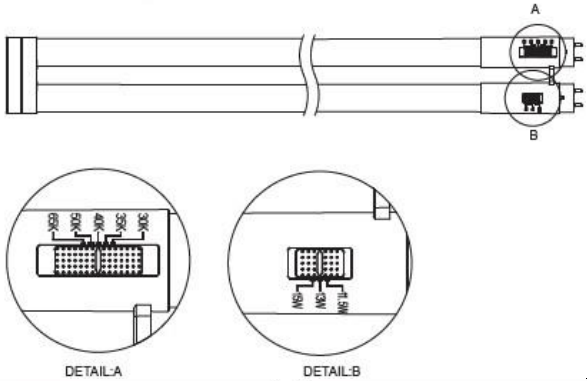
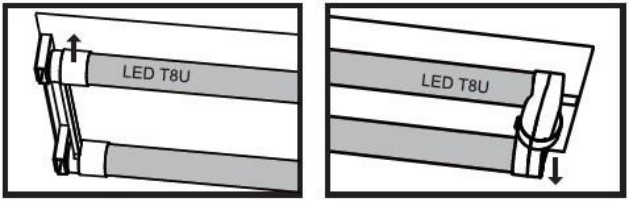
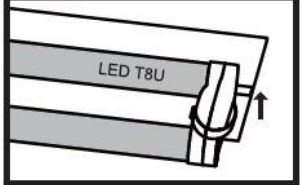
<ol style="list-style-type: none"> <li>1. Make sure the power is OFF.</li> <li>2. Remove lens or diffuser (if applicable).</li> <li>3. Remove existing fluorescent lamps from the luminaire.</li> </ol>	
<ol style="list-style-type: none"> <li>4. If installing the LED lamp as a Type A (plug-and-play) lamp, move on to step 5.</li> </ol> <p>If using the lamp as a Type B (ballast bypass), the ballast must be removed, and the fixture rewired. See the Ballast Bypass Wiring Diagrams section for how to wire the fixture. <ol style="list-style-type: none"> <li>5. A) Move the paddle to the desired color temperature.</li> <li>B) Move the paddle to the desired wattage.</li> </ol> </p>	
<ol style="list-style-type: none"> <li>6. Place LED lamp in the luminaire, ensuring that the front points away from the back of the luminaire, and insert lamp pins into the luminaire lamp holders.</li> </ol>	
<ol style="list-style-type: none"> <li>7. Insert lamp holder on the other side of the lamp pins into the metal hook of the luminaire.</li> <li>8. Place the lens or diffuser back in place (if applicable).</li> <li>9. Turn the power ON.</li> </ol>	



## Ballast Bypass Wiring Diagrams

### Single-ended Wiring

The below ballast wiring diagrams represent typical configurations. The actual ballast wiring varies according to the ballast model. The socket should be non-shunted.

#### Retrofit luminaire with 1 lamp

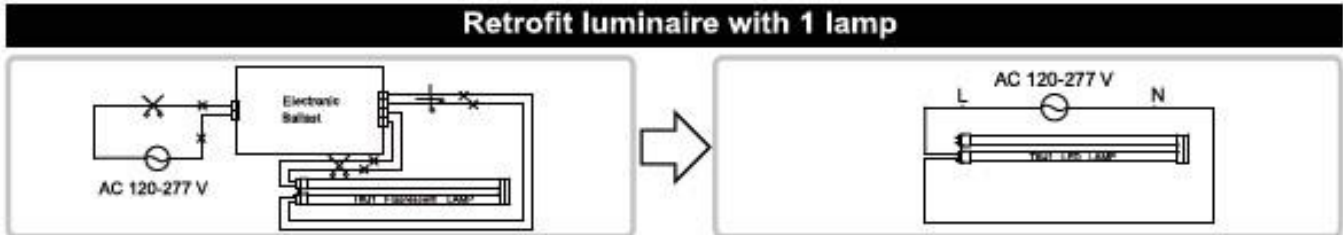

#### Retrofit luminaire with 2 lamps

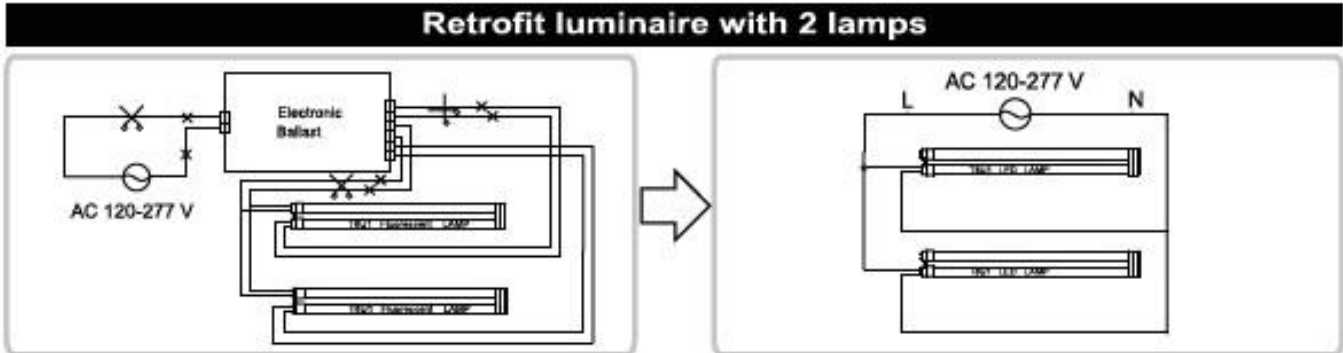

#### Retrofit luminaire with 4 lamps

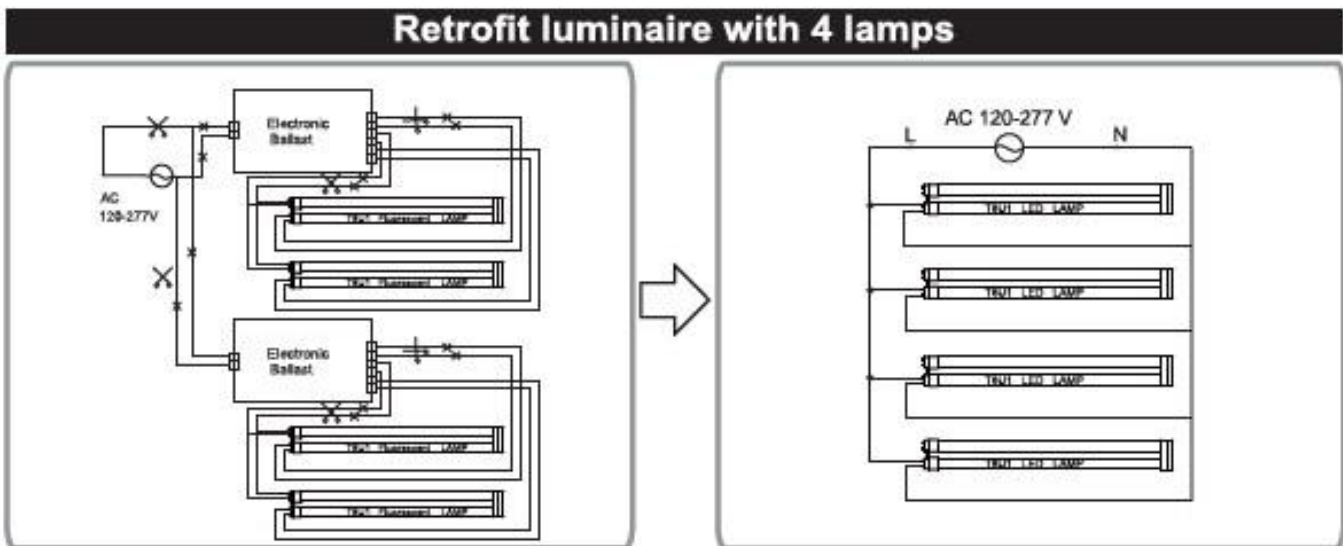



# COLOR/WATTAGE SELECTABLE LED T8 U-BEND HYBRID TUBES

## WARNING, CAUTION, SAFETY AND INSTALLATION INSTRUCTIONS

### Double-ended Wiring

The below ballast wiring diagrams represent typical configurations. The actual ballast wiring varies according to the ballast model. If the socket is in good condition, it does not need to be changed to operate double-ended lamps, regardless of the type of socket. Please make sure one side of the fixture is connected to Live (L) and the other side to Neutral (N).

#### Retrofit luminaire with 1 lamp

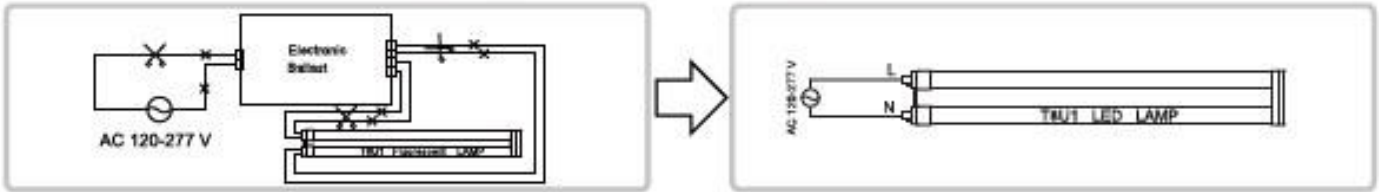

#### Retrofit luminaire with 2 lamps

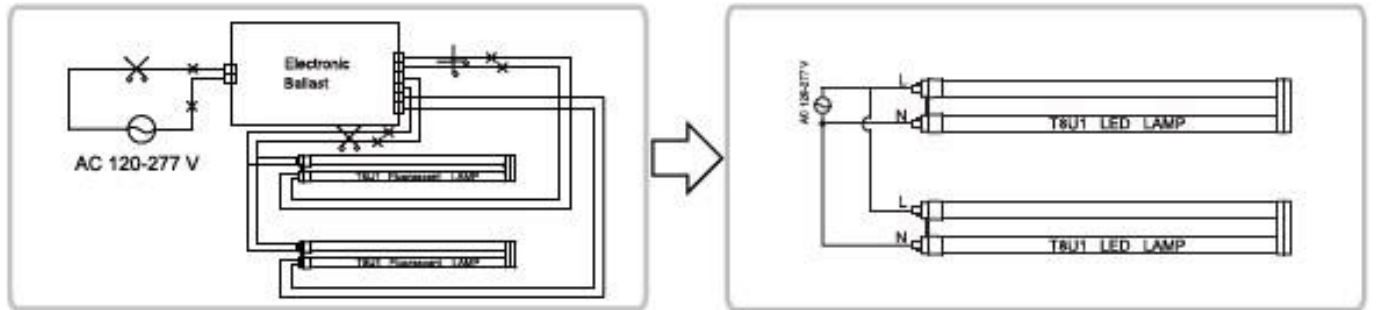

#### Retrofit luminaire with 4 lamps

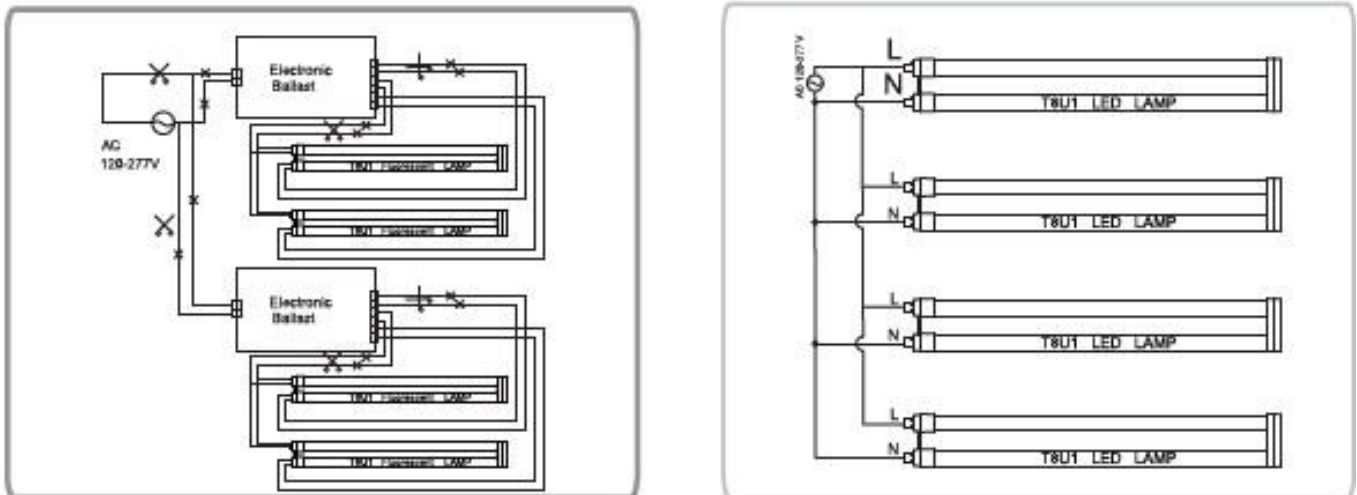



## Emergency Driver Wiring Diagrams

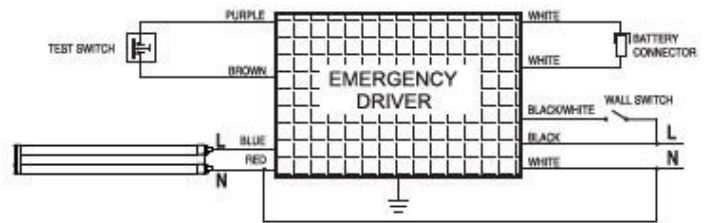
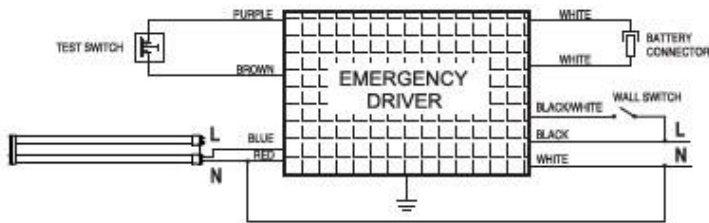

## FCC Warning

- This device complies with Part 15 of the FCC Rules when used as TYPE B lamp. Operation is subject to the following conditions: (1) this device may not cause harmful interference, and (2) this device must accept any interference received, including interference that may cause undesired operation.

## ⚠ WARNING

- Before installing, servicing, or performing routine maintenance upon this equipment, follow these general precautions.
- To reduce the risk of death, personal injury, or property damage from fire, electric shock, falling parts, cuts/abrasions, and other hazards, read all warnings and instructions included with and on the fixture box and all fixture labels.
- Proper grounding is required to ensure safety.
- Power must be turned off at the breaker before installation or maintenance.
- This product must be installed in accordance with the applicable installation code by a person familiar with the construction and operation of the product and the hazards involved.
- Wear gloves and eye protection at all times while installing, servicing, or performing maintenance on the luminaire, and avoid direct eye exposure to the light source while it is on.
- To prevent wiring damage or abrasion, do not expose wiring to edges of sheet metal or other sharp objects.
- Do not install damaged product. Inspect luminaire for damage that may have occurred during transit. If damaged, contact the manufacturer immediately.
- These instructions do not purport to cover all details or variations in equipment nor to provide every possible contingency to meet in connection with installation, operation, or maintenance. Should further information be desired or should particular problems arise which are not covered sufficiently for the purchaser's or owner's purposes, contact the manufacturer.

## ⚠ ADVERTENCIA

- Antes de instalar, reparar o realizar el mantenimiento de rutina de este equipo, siga estas precauciones generales.
- Para reducir el riesgo de muerte, lesiones personales o daños a la propiedad por fuego, descarga eléctrica, caída de piezas, cortes / abrasiones y otros peligros, lea todas las advertencias y instrucciones incluidas con y en la caja del dispositivo y todas las etiquetas del dispositivo.
- Se requiere una conexión a tierra adecuada para garantizar la seguridad.
- Se debe apagar la energía en el disyuntor antes de la instalación o el mantenimiento.



## COLOR/WATTAGE SELECTABLE LED T8 U-BEND HYBRID TUBES

### WARNING, CAUTION, SAFETY AND INSTALLATION INSTRUCTIONS

- Este producto debe ser instalado de acuerdo con el código de instalación aplicable por una persona familiarizada con la construcción y operación del producto y los peligros involucrados.
- Utilice guantes y protección para los ojos en todo momento durante la instalación, el servicio o el mantenimiento de la luminaria, y evite la exposición directa de los ojos a la fuente de luz mientras está encendida.
- Para evitar daños o abrasiones en el cableado, no exponga el cableado a bordes de láminas de metal u otros objetos afilados.
- No instale un producto dañado. Inspeccione la luminaria en busca de daños que puedan haber ocurrido durante el tránsito. Si está dañado, comuníquese con el fabricante de inmediato.
- Estas instrucciones no pretenden cubrir todos los detalles o variaciones en el equipo ni proporcionar todas las posibles contingencias a cumplir en relación con la instalación, operación o mantenimiento. Si desea obtener más información o si surgen problemas particulares que no están suficientemente cubiertos para los propósitos del comprador o propietario, comuníquese con el fabricante.