

BLK1000

Installation Instructions 1000 Lumen Emergency LED Retrofit Kit



bodine

! IMPORTANT SAFEGUARDS !

WHEN USING ELECTRICAL EQUIPMENT, BASIC SAFETY PRECAUTIONS SHOULD ALWAYS BE FOLLOWED, INCLUDING THE FOLLOWING:

READ AND FOLLOW ALL SAFETY INSTRUCTIONS

1. **WARNING** – Risk of fire or electrical shock. Luminaire wiring and electrical parts may be damaged when drilling for installation of LED retrofit kit. Check for enclosed wiring and components.
2. **WARNING** – Risk of fire or electrical shock. LED retrofit kit installation requires knowledge of luminaires electrical systems. If not qualified, do not attempt installation. Contact a qualified electrician.
3. **WARNING** – Risk of fire or electric shock. Install this kit only in luminaires that have the construction features and dimensions shown in the drawings and where the input rating of the retrofit kit does not exceed the input rating of the luminaire.
4. **WARNING** – To prevent wiring damage or abrasion, do not expose wiring to edges of sheet metal or other sharp objects.
5. **WARNING** – Only those open holes indicated in the photographs and/or drawings may be made or altered as a result of kit installation. Do not leave any other open holes in an enclosure of wiring or electrical components.
6. This product is for use with an emergency LED lighting load in compliance with NFPA-101 and NEC 700.12.
7. Make sure all connections are in accordance with the National Electrical Code or Canadian Electrical Code and any local regulations.
8. To reduce the risk of electric shock, disconnect both normal and emergency power supplies before servicing. Follow the instructions in the OPERATION section to disable the output of this LED driver.
9. This emergency driver is intended to be mounted and enclosed within a luminaire and is suitable for both factory or field installation. For field installation, please see "Step #1 Determine Suitability" on Page 2 of these instructions.
10. This product is suitable for use in damp locations where the luminaire's ambient temperature is 0°C minimum, +30°C maximum. Product is also suitable for installation in sealed and gasketed fixtures. Product is not suitable for heated air outlets and wet or hazardous locations. Maximum allowable case temp is 65°C. See unit label for Tcase measurement location.
11. An unswitched AC power source is required (120-277 VAC, 50/60 Hz).
12. Do not install near gas or electric heaters.
13. Do not attempt to service the battery. A sealed, no-maintenance battery is used that is not field replaceable. Contact the manufacturer for information on service.
14. The use of accessory equipment not recommended by the manufacturer may cause an unsafe condition.
15. Do not use this product for other than intended use.
16. Servicing should be performed by qualified service personnel.
17. Equipment should be mounted in locations and at heights where it will not be subjected to tampering by unauthorized personnel.
18. For Canadian application the output terminals should be in compliance with the accessibility requirement of the Canadian Electric Code.
19. This device complies with part 15 of the FCC Rules. Operation is subject to the following two conditions: (1) this device may not cause harmful interference, and (2) this device must accept any interference received, including interference that may cause undesired operation.
20. This product must be grounded. See the wiring diagrams for details.
21. The retrofit kit is accepted as a component of a luminaire where the suitability of the combination shall be determined by authorities having jurisdiction. Product must be installed by a qualified electrician in accordance with the applicable and appropriate electrical codes. The installation guide does not supersede local or national regulations for electrical installations.
22. This LED retrofit kit shall only be used with UL Listed recessed or surface mounted, closed type luminaires with lens with minimum dimensions W=3.5", L=24", D=4.75".
23. This LED Retrofit kit shall be installed at a maximum mounting height of 21.88 feet.

SAVE THESE INSTRUCTIONS



**THIS PRODUCT CONTAINS A RECHARGEABLE LITHIUM-ION BATTERY.
THE BATTERY MUST BE RECYCLED OR DISPOSED OF PROPERLY.**

INSTALLATION



Make sure the necessary branch circuit wiring is available. An unswitched source of power is required. The emergency driver must be fed from the same branch circuit as the AC driver. Ensure all warnings have been read and understood prior to installation.

Installation of this emergency LED retrofit kit will vary based on the luminaire type, however, generally follow these steps:

STEP #1 ► DETERMINE SUITABILITY

This product is suitable for retrofit field installation with included LED module on luminaires including LED luminaires, fluorescent lamps and others.

Ensure there will be sufficient light output in the end application. Estimate the egress lighting illumination levels by doing the following:

- A. The emergency LED retrofit kit provides 1000 lumens of output light in emergency mode to light the path of egress. The LED module provided with this kit has a lumen per watt rating of 181 lm/w typically.
- B. Using the 1000 lumen output of the LED module included with the kit and industry standard lighting design tools, calculate the anticipated illumination levels in the path of egress.

NOTE: After installation, it will be necessary to measure the egress lighting illumination levels to ensure it complies with national, state, and local code requirements.

VERIFY ALL PARTS ARE PRESENT FOR THE LED RETROFIT KIT

- > **Ensure all parts listed for the emergency LED retrofit kit are within the kit before beginning installation.**

Parts in the kit are the following: (1) BLK1000 driver, (1) 1000-Lumen LED module, (1) Black 18AWG wire for AC mains hot connection, (1) White 18AWG wire for AC mains neutral connection, (1) plenum-rated two-wire connection for the module, (1) test switch, and (4) sheet metal screws.

STEP #2 ► INSTALLING THE EMERGENCY LED RETROFIT KIT

MOUNTING HEIGHT: This emergency LED retrofit it has a maximum mounting height of 21.88 feet. Many factors influence emergency illumination levels, such as the luminaire design and the environmental, therefore end use verification is necessary. The level of illumination must be measured in the end application to ensure the requirements of NFPA 101 and local codes are satisfied. This emergency LED retrofit kit shall be installed at a max mounting height of 21.88 feet.

- A. **Figure 1** illustrates the parts of a luminaire. Luminaires may differ from the one illustrated here. Verify all parts and connections before beginning installation.

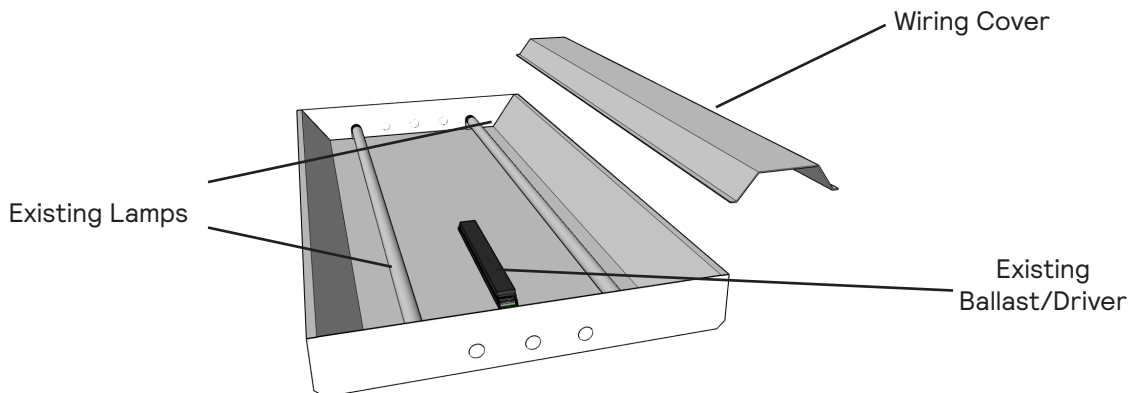

Figure 1. Luminaire and components, pre-modification

- B. Remove AC mains from the luminaire. Verify power is disconnected.
- C. If the lamp has a lens/cover, remove it to access the internals of the luminaire. If lamps are connected to the luminaire, remove them. Open and remove the driver/ballast cover.

- D. For the installation of the emergency driver and LED module, you will need to drill holes in the positions illustrated in **Figure 2** ((2) 1/8" holes for driver, (2) 1/8" holes for module, and one 1/2" hole for test switch). If the luminaire differs from the one illustrated here:
- The emergency driver can be installed near the the ballast.
 - Ensure the LED module location is visible from the ground.
 - After drilling holes, ensure edges of holes are grommetted or deburred.

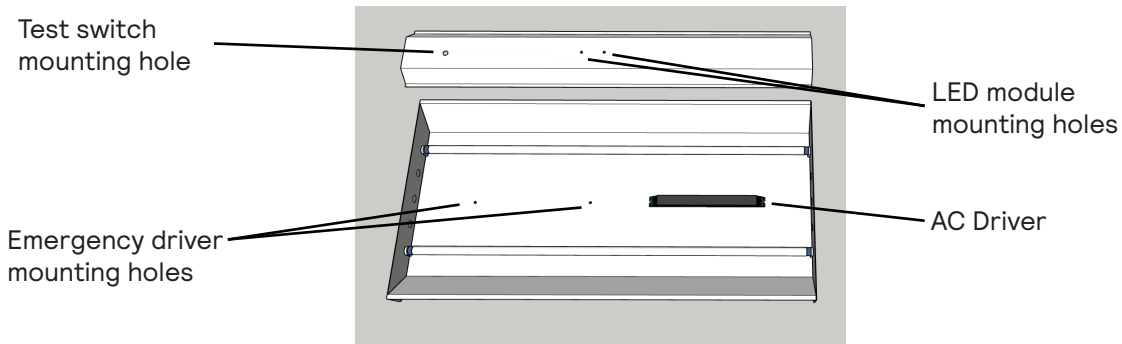

Figure 2. New hole location details

- E. Install the emergency driver utilizing 2 of the 4 screws provided into the driver channel per **Figure 3**. Install the LED module utilizing 2 of the 4 screws provided into the ballast cover on the visible side of the ballast cover per **Figure 3**. Ensure secure installation of both emergency driver and LED module.

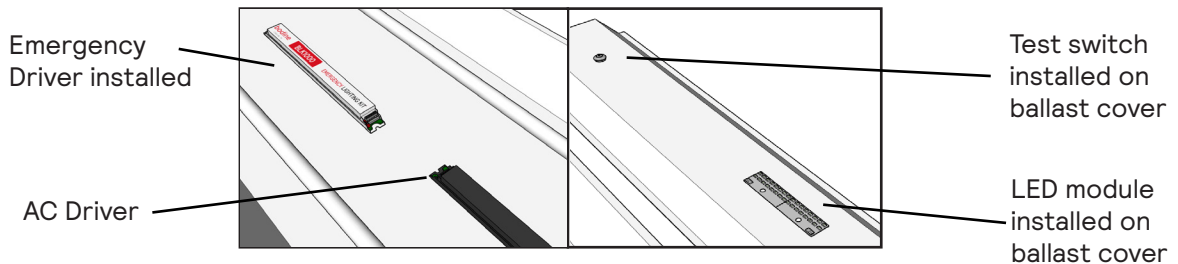

Figure 3. Installation location (driver to left and module to right)

- F. For wiring instructions, please refer to the **wiring diagram on Pg. 5**.

- G. Once wired, prepare to install the test switch. Once your test switch has been installed (per STEP #3), reinstall the ballast cover. Your luminaire should appear similar to **Figure 6**.

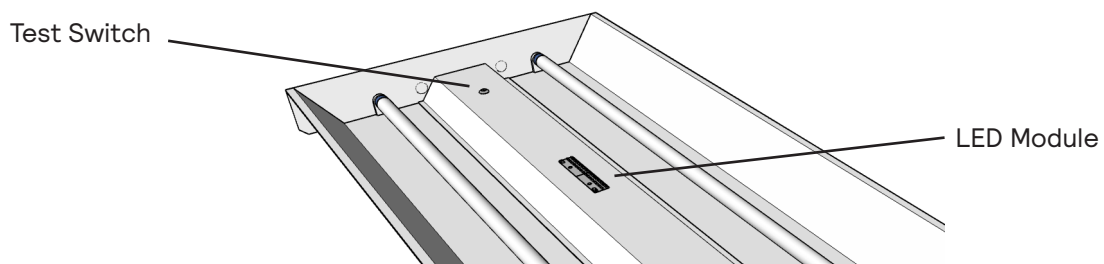
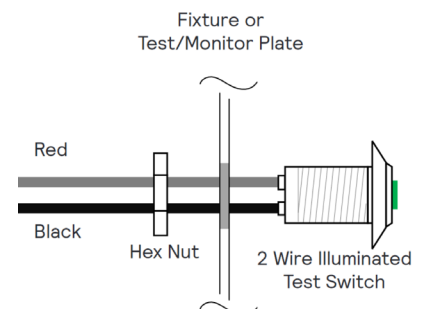

Figure 6. Completed Luminaire

STEP #3 ► INSTALLING THE ILLUMINATED TEST SWITCH

- > Mount the supplied Illuminated test switch in a location that is visible and accessible by maintenance personnel. The test switch mounts through a 1/2" hole which may need to be made in the luminaire or could come pre-punched by the luminaire supplier.
- > Connect the test switch per wiring diagrams provided on these instructions.
- > If wired correctly, the indicator light should be ON when AC power is supplied to the fixture indicating that the unit is charging. After installing, mark with the "PUSH TO TEST" and "CHARGING INDICATOR LIGHT" labels.



STEP #4 ► TESTING OPERATION

- > Make sure all connections are in accordance with the National Electrical Code and any local regulations.
- > After installation of the emergency LED retrofit kit is complete, supply AC power to the luminaire.
- > At this point, the Charging Indicator Light should illuminate indicating the internal battery is charging.
- > After the emergency LED retrofit kit has been charged for one-hour, an automatic commission test will be performed. The emergency driver will switch to the emergency mode for 30 seconds and store in its memory the current level of the connected load. If, during future self-test this level deviates by more than 25%, an error will be triggered.
- > A short-term discharge test may be conducted after the emergency LED retrofit kit has been charged for one hour. Charge for 24 hours before conducting a long-term discharge test. Refer to OPERATION.
- > In a readily visible location, attach the label "CAUTION - This Unit Has More Than One Power Connection Point. To Reduce The Risk Of Electric Shock, Disconnect Both The Branch Circuit-Breakers Or Fuses And Emergency Power Supplies Before Servicing."

OPERATION

Applying AC power to the emergency LED retrofit kit driver activates the charger circuit, and supplies power to the control/monitor circuit and charging indicator light. When AC power fails, the emergency driver of the kit automatically switches to emergency mode, powering the 1000 lumen LED module for a minimum of 90 minutes. When AC power is restored, the emergency driver of the kit returns to charging mode, and normal operation of the luminaire resumes.

To deactivate the unit for storage or shipping, press and hold the test button while the unit is in emergency mode until the LED load is turned off.

MAINTENANCE

This self testing emergency LED retrofit kit automatically performs required routine testing. Results are reported to maintenance personnel via the indicator light.

Note: Maintenance personnel should periodically check the indicator light. If the indicator light is flashing, follow steps in the Troubleshooting Guide.

SELF-TESTING OPERATION

Self-test select features:

A slide switch is used to enable and disable the self-test feature of the product.

Switch Position	Function
ON	Self-test feature Enabled
1	Self-test feature Disabled

This unit contains a control/monitor circuit that if enabled automatically performs a 30-second discharge test once a month and a full 90-minute discharge test once a year. During routine testing, the self-testing emergency driver simulates an AC power failure causing the unit to automatically switch to emergency mode. The unit will monitor the operation of the LED load, battery voltage, and emergency duration. If the emergency system functions properly, then the unit will return to normal mode. Should the unit detect any problems, the indicator light will flash per failure condition (see Troubleshooting Guide) until the condition has been corrected and the unit passes the next test.

To reset a failure indication, briefly push the Test Switch. If the condition has not been corrected by the next scheduled test, the unit will once again detect the failure and signal the failure indicator.

To perform a manual self-diagnostic test, push and hold the Test Switch for minimum of 5 seconds. Once the test switch is released, the emergency driver will perform a 30 second diagnostic test. During this test, unit will monitor the operation of the LED load, and battery voltage. If the emergency system functions properly, the unit will return to normal mode. Should the unit detect any problems, the indicator light will flash per failure condition (see Troubleshooting Guide) until the condition has been corrected and the unit passes the next test.

TROUBLESHOOTING GUIDE

If the unit has encountered a problem after installation, then the Illuminated Test Switch will flash the error code with the indicator light. Count the number of times the indicator is OFF to read the number of flashes. Then use the troubleshooting steps to solve the issue.

Bi-Color indicator (color/flashing)	ERROR	CORRECTIVE ACTION
Green/ No Flashes	None	The unit is operating correctly, and the internal battery is fully charged
Green/ Slow Flashes	None	<ol style="list-style-type: none"> The Unit is charging. The main light is operating normal. The Unit is running a self-diagnostic test. The LED Load is operating in Emergency level.
OFF	None	In emergency mode, or emergency run-time is ended and unit is de-activated.
Red / 2x Flashes	Battery	<p>Indicates that a self-test/self-diagnostic test did not meet full duration</p> <ol style="list-style-type: none"> Charge the unit for the rated recharge time and perform a manual self-diagnostic test. If error is still present, then the battery is past it's useful life and should be replaced.
Red / 3x Flashes	Charging	<ol style="list-style-type: none"> Check input AC mains wiring of Unswitched Hot, Neutral and Ground. Verify Voltage and Frequency are stable and match the product's input rating on the label
Red / 4x Flashes	LED Load, Commissioning	<p>During a self-test/self-diagnostic test, the unit detected the LED load has changed more than 25% from the initial commissioned value.</p> <ol style="list-style-type: none"> Replace the LED Load and perform a manual self-diagnostic. If error is still present, then recalibrate the commission value by deactivating the unit. Apply AC mains to activate unit and it will recommission itself after one hour. Check for Open or Short circuit on the output connections.
Red / 5x Flashes	Temperature	<p>Product temperature is beyond its rated temperature range.</p> <ol style="list-style-type: none"> Ensure unit is within the rated temperature range stated on the product label. Confirm by measuring at the Tc point on the product label.

WIRING DIAGRAM

EMERGENCY DRIVER AND AC DRIVER MUST BE FED FROM THE SAME BRANCH CIRCUIT

TYPICAL SCHEMATICS ONLY. MAY BE USED WITH OTHER DRIVERS. CONSULT THE FACTORY FOR OTHER WIRING DIAGRAMS.

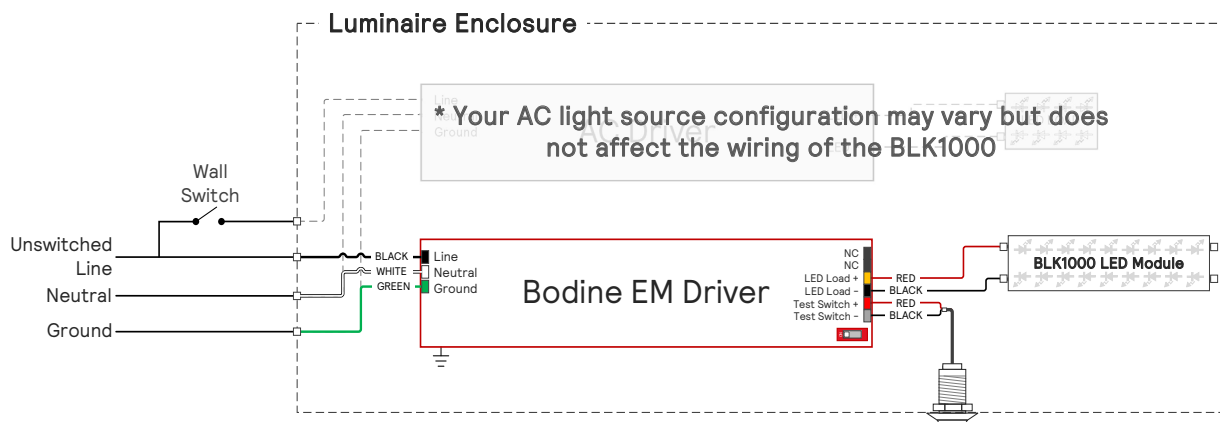

NOTE:

For short-term testing of the emergency function, the battery must be charged for at least one hour. The emergency driver must be charged for at least 24 hours before conducting a long-term test.