

# Installation Instruction

---

## WARNING

- To reduce the risk of death, personal injury or property damage from fire, electric shock, falling parts, cuts/abrasions, and other hazards read all warnings and instructions included with and on the fixture box and all fixture labels.
- Before installing, servicing, or performing routine maintenance upon this equipment, follow these general precautions.
- Commercial installation, service and maintenance of luminaires should be performed by a qualified licensed electrician.
- For the installation: If you are unsure about the installation or maintenance of the luminaires, consult a qualified licensed electrician and check your local electrical code.
- To prevent wiring damage or abrasion, do not expose wiring to edges of sheet metal or other sharp objects.
- Do not make or alter any open holes in an enclosure of wiring or electrical components during kit installation.

## WARNING

- Turn off electrical power at fuse or circuit breaker box before wiring fixture to the power supply.
- Turn off the power when you perform any maintenance.
- Verify that supply voltage is correct by comparing it with the luminaire label information.
- All wiring connections should be capped with UL approved wire connectors.

## CAUTION

- Avoid direct eye exposure to the light source while it is on.
- Account for small parts and destroy packing material, as these may be hazardous to children.
- Risk of burn. Disconnect power and allow fixture to cool before handling fixture.

**NOTICE:** Green ground screw provided in proper location. Do not relocate.

**NOTICE:** Minimum 90° supply conductors.

**NOTICE:** Specifications and dimensions subject to change without notice.

**NOTICE:** Suitable for Dry or Damp location, Type IC.

---

Any further questions or interests, please visit



[www.pltsolutions.com](http://www.pltsolutions.com)

# Installation Instruction

---

## INSTRUCTIONS:

Always turn off the power supply from main circuit breaker first!

Figure 1

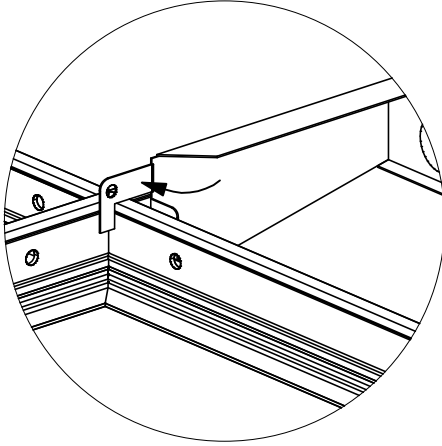

Figure 2

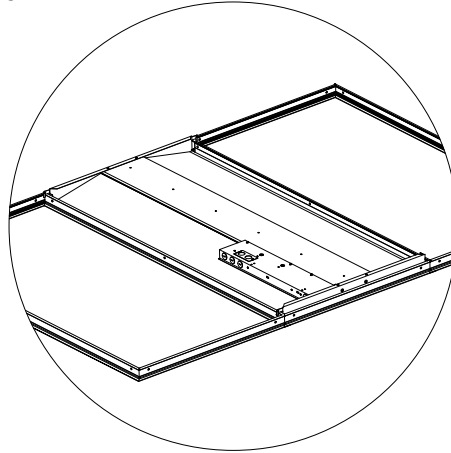

Figure 3

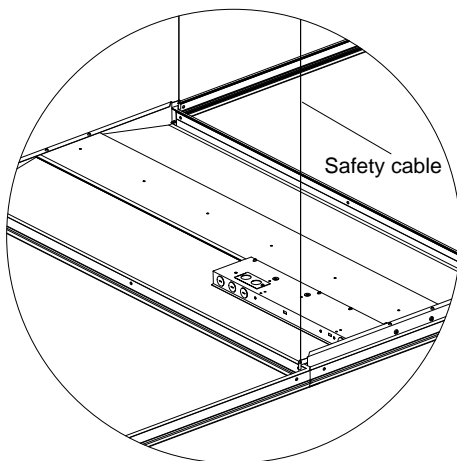
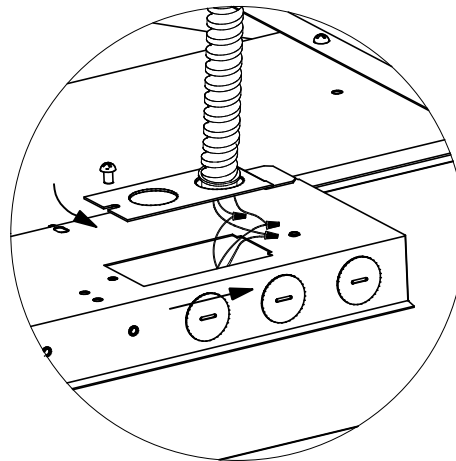

Figure 4



## Installation Steps:

Figure 1: Bend out mounting tab 90 degrees on each corner.

Figure 2: Lay fixture into T-gird grid.

Figure 3: Use hanger wire to tie off appropriately in accordance with local building code.

Figure 4: Install conduit containing the line, neutral, and ground conductors to the knockout of the cover plate. Make all electrical connections to the fixture. Attach the wiring access cover plate.



Any further questions or interests, please visit

[www.pltsolutions.com](http://www.pltsolutions.com)



# Installation Instruction

## Emergency Driver and Battery

- Emergency Battery Back-up, EM Model: HT-EM-10W-120-277-FT-XXXX

Notice: Always turn off the power supply from main circuit breaker first!

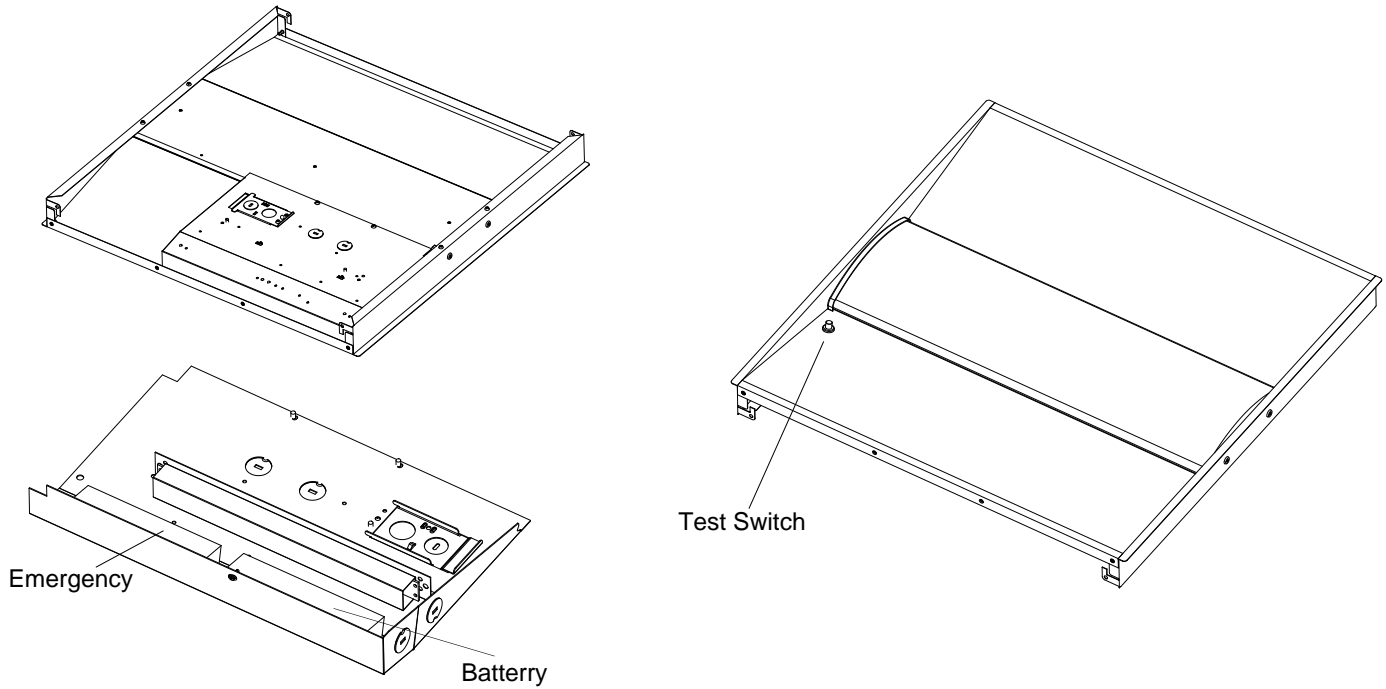

## General Wiring Diagram

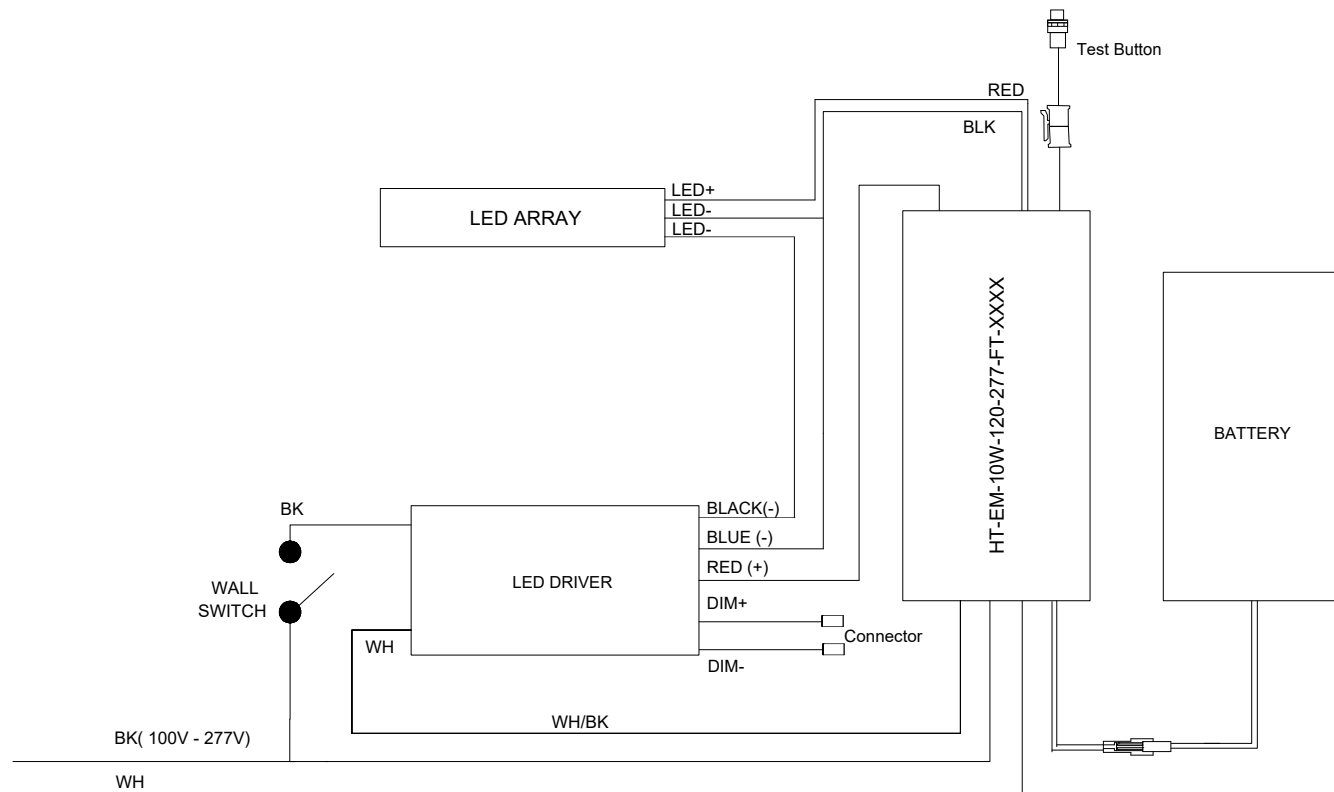

Any further questions or interests, please visit

[www.pltsolutions.com](http://www.pltsolutions.com)

# Installation Instruction

---

## TEST SWITCH INDICATOR STATUS:

LED Indicators Status	EM Driver Status/Mode
• Solid Green	• System OK/AC OK
• Red indicator flashing, 4S ON, 1S OFF	• Low battery voltage,Self-Diagnostic failed
• Green indicator, 1S ON, 1S OFF	• Self-Diagnostic mode
• The indicators light OFF	• Power grid turn off,Emergency mode
• Alternate brightness of red and green,1S RED,1S GREEN	• Load Open
• Red indicator flashing, 1S ON, 1S OFF	• Load short,Self-Diagnostic mode
• Alternate brightness of red and green,4S RED,1S GREEN	• Self-Diagnostic and the output current exceeds 25% of the rated value

## Self-Diagnostic mode

- |  |
|--|
| • 1.Each month auto self diagnaostic           |
| • 2.Each Year auto self diagnaostic 90 mintues |

## Self-Diagnostic Mode Enable and Disable operation method

**Dip Switch** enable position and Learned LED load will enable Self-Diagnostic function , other situations are disabled.

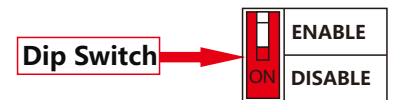

## Recharge time

-12hours

## Operation time

-90 minutes with 1000-1500 lumens output

The fixture can be switched off by connected wall switch. When emergency conditions (main power off), use wall switch to turn on the fixture which will be running in emergency mode.



Any further questions or interests, please visit

[www.pltsolutions.com](http://www.pltsolutions.com)

# Installation Instruction

---

PLEASE READ CAREFULLY AND FOLLOW ALL INSTRUCTIONS FOR YOUR OWN SAFETY

- IMPORTANT:** An un-switched AC power source of 100VAC to 277VAC is required for the yellow/black and white leads.
- IMPORTANT:** A switched or un-switched AC power source of 100VAC to 277VAC is acceptable for the black lead only.
- This device is designed for use in fixtures listed for **damp location**.
- CAUTION:** Do not use outdoors.
- CAUTION:** The use of accessory equipment not recommended by the manufacturer may cause an unsafe condition.
- CAUTION:** Make sure all electrical connections conform to the National Electrical Code and all applicable local regulations.
- CAUTION:** Do not mount near gas or electric heaters.
- CAUTION:** Do not use this emergency driver with accessory equipment other than recommended by manufacturer; failure to follow this may cause an unsafe condition. Servicing should only be performed by qualified service personnel.
- CAUTION:** Do not use this emergency driver for other than intended use.
- CAUTION:** Battery is rechargeable LiFePo4 type and must be recycled or disposed of properly.
- CAUTION:** Equipment should be mounted in locations and at heights where it will not readily be subjected to tampering by unauthorized personnel.

## SAVE THESE INSTRUCTIONS

**TESTING SYSTEM:** The emergency battery requires a minimum charge time of one (1) hour before testing the circuit. A minimum of twelve (12) hours is required for a full charge.

**IMPORTANT:** In order to maintain proper operation and warranty coverage, the battery must be recharged once per year prior to installation.

**RATED EMERGENCY OPERATION:** Ninety (90) minutes for the 10W load

**Max. mounting height: \_\_17.7\_\_ ft ( \_\_5.39\_\_ m)" or the equivalent.**

Model: HT-EM-10W-120-277-FT-XXXX

Associated Target Luminaire: E485624 (**PRECISION LIGHTING & TRANSFORMER, INC.**), Model PLT-90352 and PLT-90353, with LED model BXEN-49E-11M-3AA, made by Bridgelux



Any further questions or interests, please visit

[www.pltsolutions.com](http://www.pltsolutions.com)