



# LED AREA LIGHT



## APPLICATION

Parking Areas| Automotive Dealerships| Roadways | Campuses| Streets Capes| Airports |  
Area security lighting | Building facades| Signs | Entryways





# LED AREA LIGHT

## GENERAL FEATURES

- Low-profile, stylish design with durable powder coat finish
- Powered by 0-10V dimming LED drivers
- Available with Type 3\* and Type 5 light distributions
- Quick install mounting arms: Slipfitter, Straight Arm, Trunion\*, U-bracket
- Ambient operating temperature: -40°C/-40°F to 45°C/113°F
- UL listed for wet locations, IP65
- Power Factor: >0.95
- THD: <20%
- Meets FCC Part 15, Part B, Class A standards for conducted and radiated emissions

## MOUNTING ARMS

PLT-13008  
Slipfitter

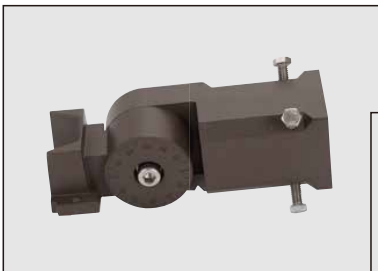

PLT-13007  
Straight Arm for Round or  
Square Poles



Trunion\*

PLT-13006  
Straight Arm for Square Pole



PLT-13004  
U-Bracket

\*Available via Special Order. Please call 1-800-624-4488.



# LED AREA LIGHT

## DIMENSIONS

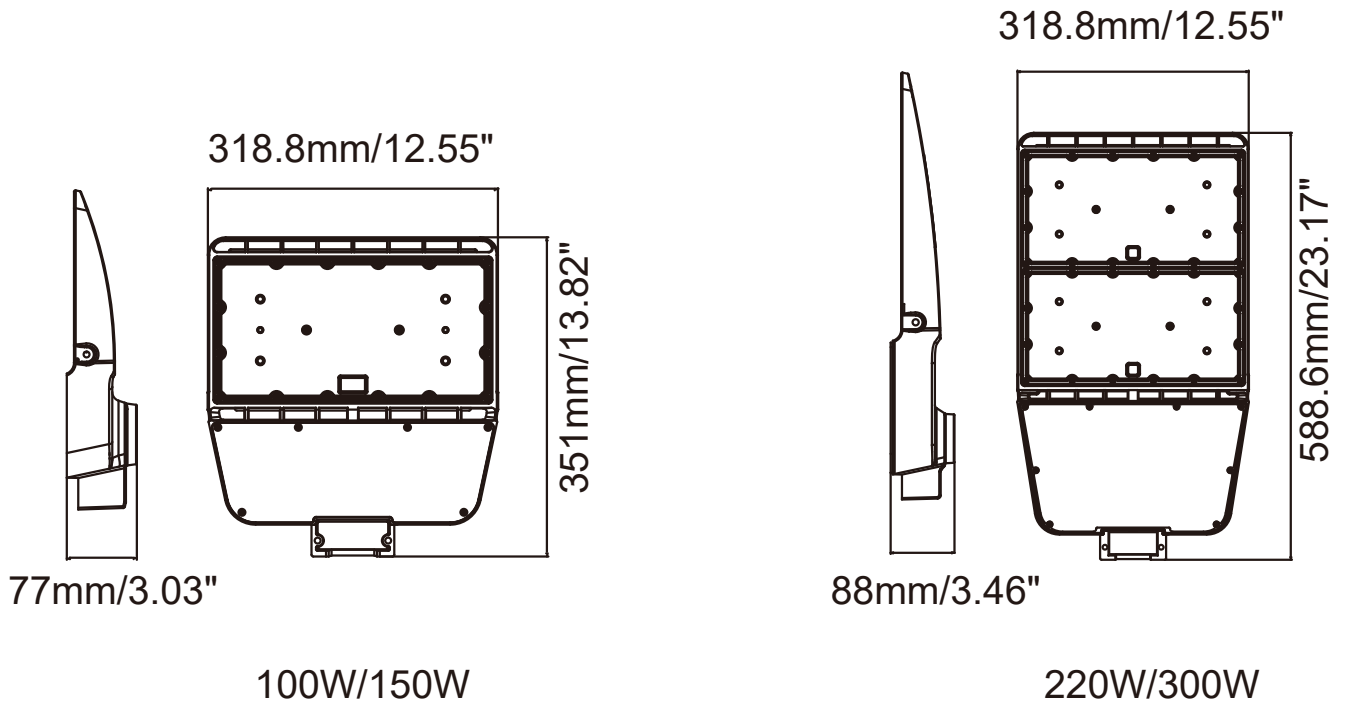

## ELECTRICAL SPECIFICATIONS

Model	Power	CCT	Lumen±5%	lm/w ±5%	Voltage	CRI	Type	Equivalence	Weight
PLT-13134	260W/ 280W/ 300W	3000K/ 4000K/ 5000K	45,000 Max	160*	120-277VAC	>70	Type5	1000W	13.56 lbs



# LED AREA LIGHT

## LIGHT DISTRIBUTIONS

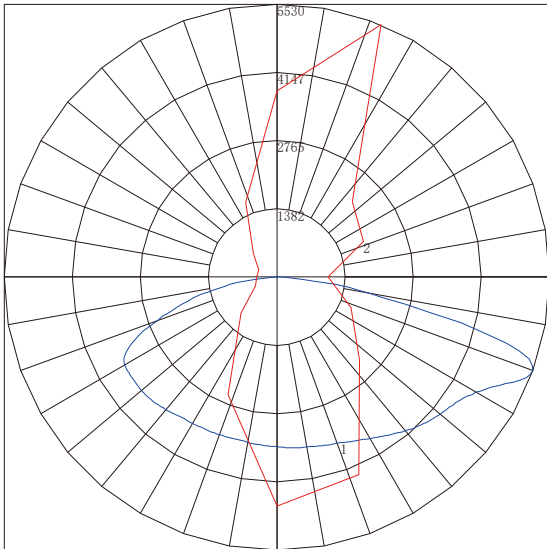

Type III\*

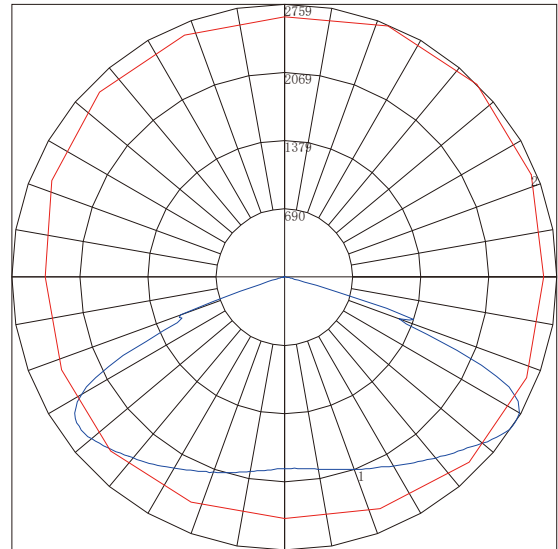

Type V

## GENERAL WIRE DIAGRAM

### LED DRIVER

