

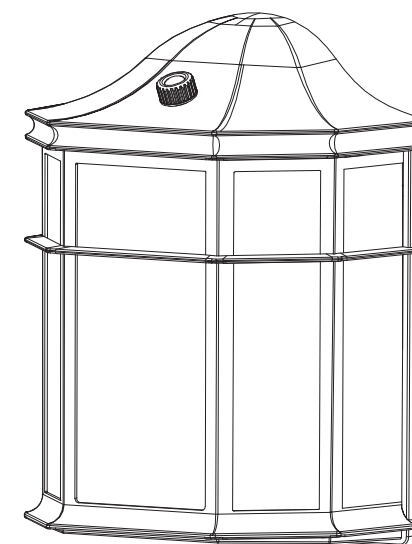

# LED Wall Pack

*Installation Instructions*



## PACKAGE CONTENTS

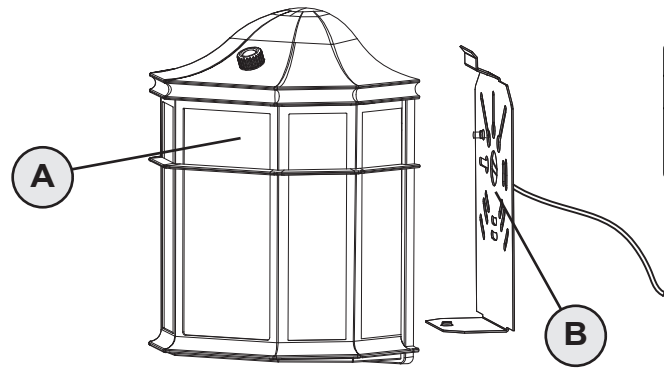

Part	Item Name	Qty.
A	Fixture	1
B	Mounting Plate (preassembled to fixture)	1

## HARDWARE CONTENTS

AA



Wire Nuts  
Qty. 3

BB



Junction Box  
Screws  
Qty. 4

## SAFETY INFORMATION

Please read and understand this entire manual before attempting to assemble, operate or install the product. Failure to do so could lead to electric shock, fire or other injuries that could be hazardous or even fatal.

- Be sure the electricity to the wires you are working on is shut off. Either remove the fuse or turn off the circuit breaker.
- Changes or modifications not expressly approved by the party responsible for compliance could void the user's authority to operate the equipment.
- This product must be installed in accordance with local, state and national electrical codes.
- Installation work shall be completed by a licensed installer that is familiar with the construction and operations of the product.

### CAUTION:

- The fixture body is one piece. Do not disassemble it.
- This product can NOT be dimmed, do not installed in a dimming switch circuit.

### NOTICE

- This device complies with Part 15 of the FCC Rules. Operation is subject to the following two conditions: (1) This device may not cause harmful interference, and (2) this device must accept any interference received, including interference that may cause undesired operation.

## SAFETY INFORMATION

- This equipment has been tested and found to comply with the limits for a Class B digital device, pursuant to part 15 of the FCC Rules. These limits are designed to provide reasonable protection against harmful interference in a residential installation. This equipment generates, uses and can radiate radio frequency energy and, if not installed and used in accordance with the instructions, may cause harmful interference to radio or television reception, which can be determined by turning the equipment off and on. The user is encouraged to try to correct the interference by one or more of the following measures:
  - Reorient or relocate the receiving antenna.
  - Increase the separation between the equipment and the receiver.
  - Connect the equipment into an outlet on a circuit different from that to which the receiver is connected.
  - Consult the dealer or an experienced radio/TV technician for help.

## PREPARATION

Before beginning assembly of product, make sure all parts are present. Compare parts with package contents list and hardware contents list. If any part is missing or damaged, do not attempt to assemble the product.

**Estimated Assembly Time:** 15 minutes.

Tools Required for Assembly (not included): Phillips screwdriver, flathead screwdriver, safety glasses.

## INSTALLATION INSTRUCTIONS

To ensure a safe and proper installation, ensure that power is disconnected to the supply wires.

1. Locate the thumbscrew in the bottom opening of the fixture (A), turn counter-clockwise and remove, set aside thumbscrew. Pull the bottom (near the location of the thumbscrew) of the mounting plate (B) away from fixture and slide out the upper tab to release the mounting plate (B). Set aside the fixture (A).

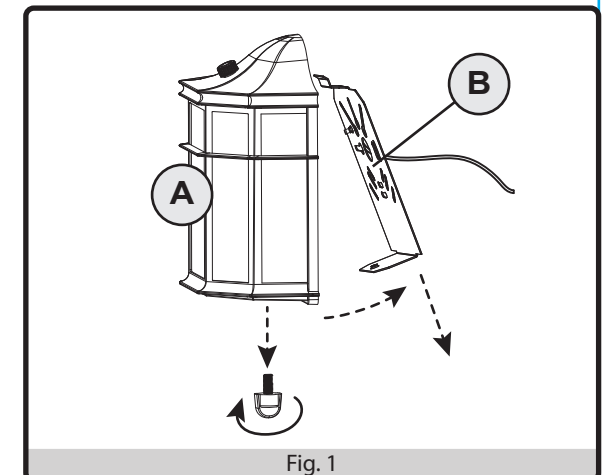

## INSTALLATION INSTRUCTIONS

2. Pull the supply wires from the junction box in the intended mounting surface through the center opening of the mounting plate (B), including the ground lead attached to the mounting plate (B). Secure Mounting plate (B) to junction box with junction box screws (BB), ensure the orientation is level before tightening screws.

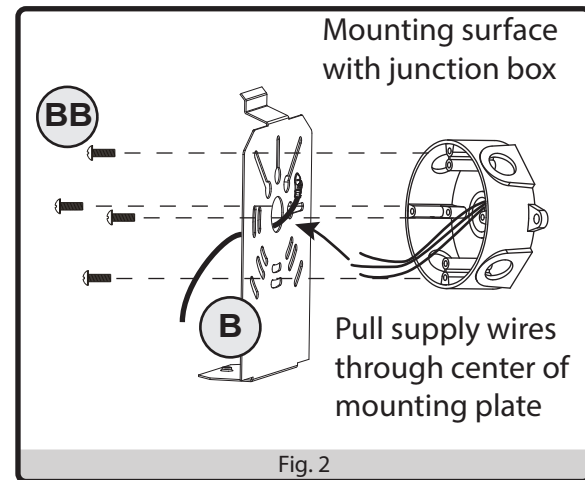

3. Connect the fixture wires to the supply wires -- black to black, white to white, and green to copper/bare. **WARNING:** If there is no ground supply wire, stop installation and consult a qualified electrician.

Once wire connections are made, secure each with a wire nut (AA).

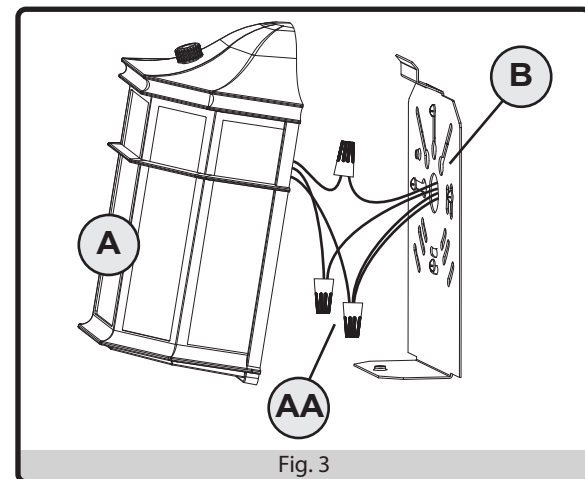

4. Insert the upper tab on mounting plate (B) through the slot on the back of the fixture (A) housing, then swing the bottom towards the mounting surface until flush. Replace the thumbscrew from step 1 above by turning clockwise back into the fixture until fixture is fully secured.

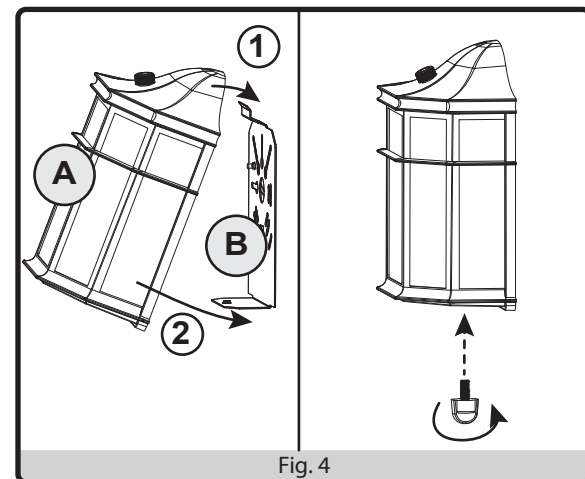

## CARE AND MAINTENANCE

Clean with a mild, non-abrasive glass cleaner and soft cloth. Do NOT use solvents or cleaners containing abrasive agents. When cleaning the fixture, make sure the power is turned off, and any liquid spray should be applied to the cleaning cloth and not sprayed directly onto the fixture itself.

## TROUBLESHOOTING

Problem	Possible Solution	Corrective Action
Fixture does not light.	1. Power is off. 2. Incorrect wire connection. 3. Defective wall switch.	1. Check circuit breaker or wall switch. 2. Check wire splices. 3. Replace switch.
Circuit breaker trips when light is turned on.	Crossed wires or power wire is grounded out.	Verify wires are correctly connected.

## WARRANTY

This fixture is warranted to perform free from defects for five years. If it fails to do so, you may return it with proof of purchase to 13445 12th St., Chino, CA 91710 for replacement.