



LED Tape Light Channel – Recessed Mount

DESCRIPTION

Create custom fixtures for your LED tape light with these recessed channels and their compatible accessories.

FEATURES

- Comes with opaque lens
- Channel and lens can be cut to desired length
- Embeds into flat surfaces for a seamless look
- Designed for LED tape light no wider than 15mm/0.59 in
- Requires additional accessories to complete installation; see Accessories section for full list of compatible accessories.

LISTINGS

- Indoor/dry locations
- RoHS

CONSTRUCTION

- Aluminum with either black or anodized finish
- Frosted PC lens protects the tape light while diffusing light output

INSTALLATION

- Recessed mount into flat surfaces; see Installation Instructions for more information.

WARRANTY

- 3-year limited warranty; see pltsolutions.com for warranty details

Project name	Type
Catalog number	
Comments	Voltage
Approved by	Date



APPLICATIONS

- Display Cases
- Covers
- Under Cabinets
- Shelves
- Staircase Steps



PERFORMANCE SUMMARY

Item #	Mounting	Beam Angle	Tape Light Max. Width	Finish	Length
PLT-12869	Recessed	100°	15mm	Black	6.6'
PLT-12870	Recessed	100°	15mm	Anodized	6.6'

ACCESSORIES

SKU	Description	Compatible With
PLT-12871	End Cap - Grey - 2 pack	PLT-12670
PLT-12872	End Cap - Black - 2 Pack	PLT-12869

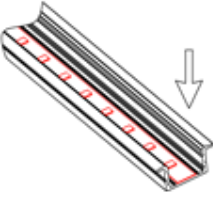
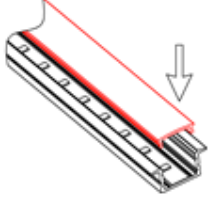
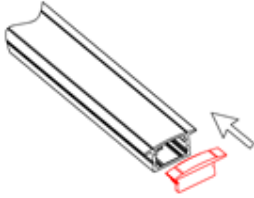
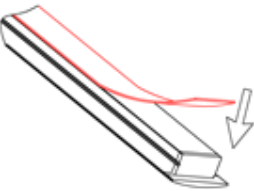
INSTALLATION

<p>1. Stick the LED strip to the channel.</p> 	<p>2. Press the diffused cover into place.</p> 	<p>3. Attach the end caps.</p> 
<p>4. Apply the adhesive tape to the back of fixture.</p> 	<p>5. Install the fixture on the surface.</p> 	<p>6. Installation complete</p> 

DIMENSIONS

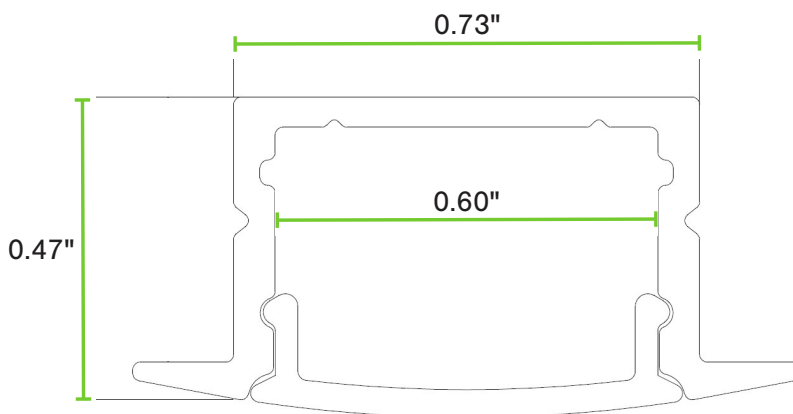

CHANNEL

Height - 0.47"

Width - 0.73"

Inner Channel Width - 0.60"

Length - 6.6'

Weight - 1.02 lbs