



# UFO LED HIGH BAY



## PRODUCT FEATURES

- 145lm/w fixture efficacy, high performance and reputable brand LED chip and driver
- Optimized aluminum alloy housing design for superior thermal management
- Clear polycarbonate lens with no risk of lamp breaking for safe industry applications
- Selectable CCT & Watt options to cut SKUs and inventory cost
- Compact size for easy operation and transportation
- 0-10V dimming
- 60\*/90/120\*deg lens options
- Plug & Play microwave sensor options\*; Aluminum reflector options\*
- UL Wet Location listed; IP65 and IK10 rated
- EM backup options\*
- LED L70 Life Hours - 50,000
- -40F to 113F Operating Temperature

\*Various customizable options available via Special Order. Call 1-800-624-4488.



# UFO LED HIGH BAY

## SPECIFICATIONS

Part No.	Power	Lumen output (+5%)	CCT	Dimming	Beam Angle	CRI	Input Voltage	Operation Temp.	Warranty	DLC
NPS-00190*	150W 150W/120W/100W Selectable	21750lm/17400lm/ 14500lm	3000K/4000K/ 5000K Selectable	0-10V	60°/90°/120°	80	120-277V	-45C to 45C -40F to 113F	5years	N/A
PLT-13005	240W 240W/220W/200W Selectable	37,200lm/34,100lm/ 32,000lm								5.1 Premium PLTBO212

## DIMENSIONS

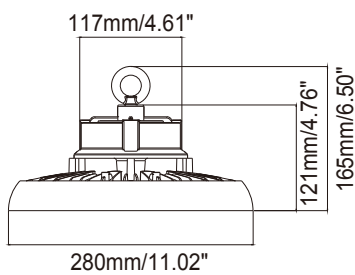
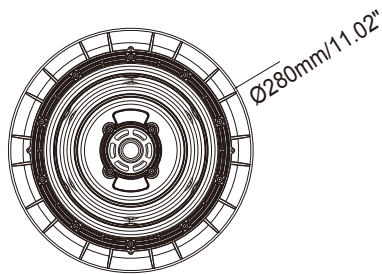

NPS-00190\*

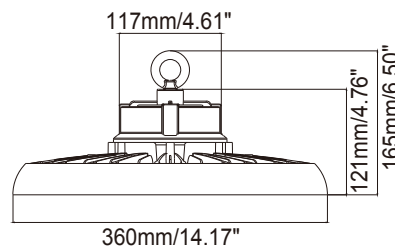
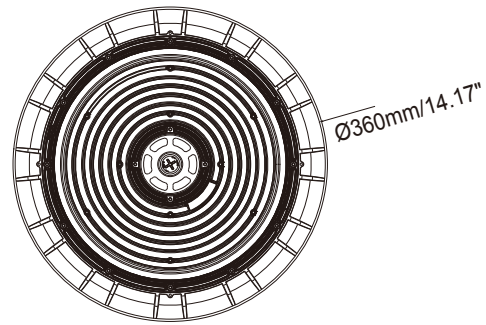

PLT-13005

## PHOTOMETRY

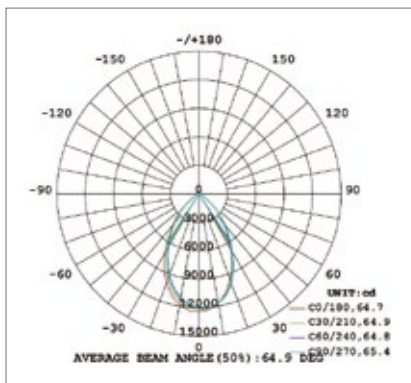

60°\*

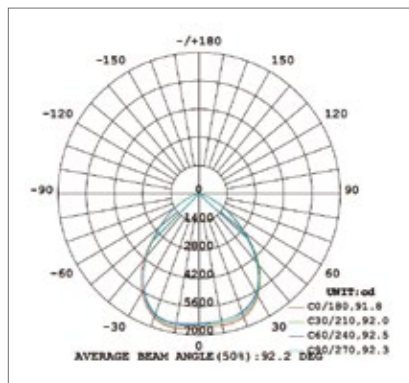

90°

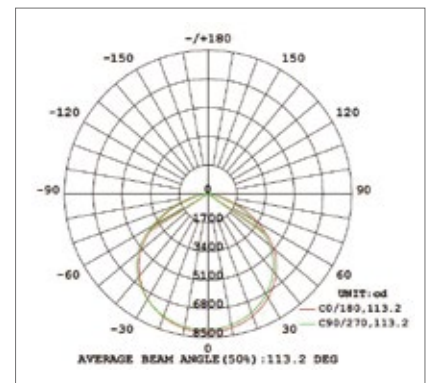

120°\*

\*Available via Special Order. Call 1-800-624-4488.



# UFO LED HIGH BAY

## WATT AND CCT SELECTABLE DIP SWITCH

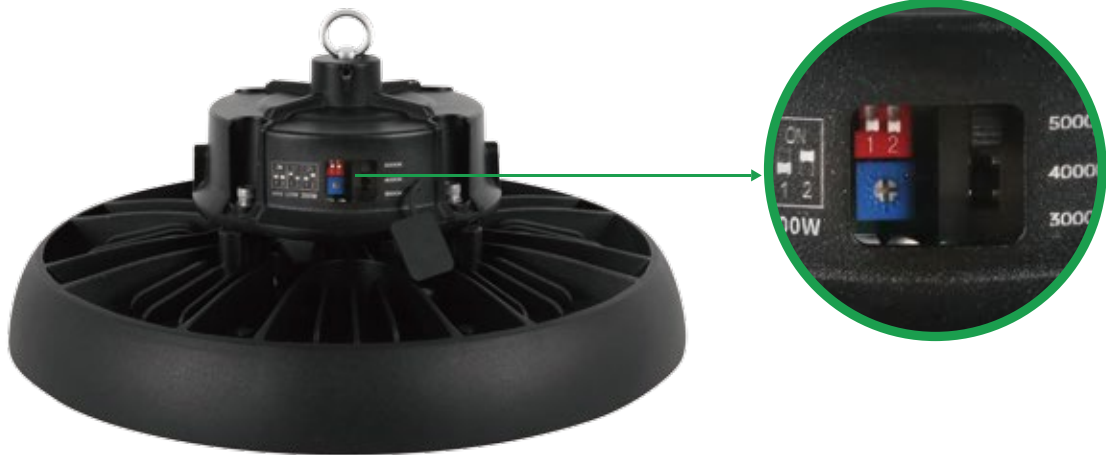

Watt Select:

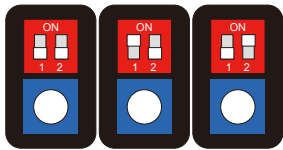

240W 220W 200W

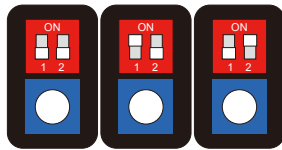

150W 120W 100W

CCT Select:

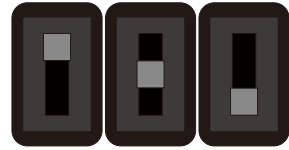

5000K 4000K 3000K

## ACCESSORIES



REMOTE CONTROL  
NPS-00191\*



MICROWAVE SENSOR  
NPS-00192\*



PIR SENSOR  
NPS-00193\*



EM BACKUP  
NPS-00194\*



REFLECTOR\*



YOKE MOUNT\*

\*Available via Special Order. Call 1-800-624-4488.



# UFO LED HIGH BAY

## EM BACKUP\* (NPS-00194)

### FEATURES

- UL listed for field or factory installation,CEC title 20 compliant
- Compliance with American NFPA 101 life Safety Code.
- Easy installation,no need to open up a luminaire to connect this device to the driver,connect with the led lamp directly.
- With built-in junction box.
- 2 -in- 1 LED test switch and indicator light included
- Manual testing via remote control (optional)
- Monthly/annual self-testing
- With multi-protection function:  
Battery overcharge protection; Battery over-discharge protection;  
Output overload protection; Short-circuit protection; Open load protection
- 5 years limited warranty



Em backup



Em backup for selectable CCT & Watt UFO

### MOUNTING CONFIGURATION

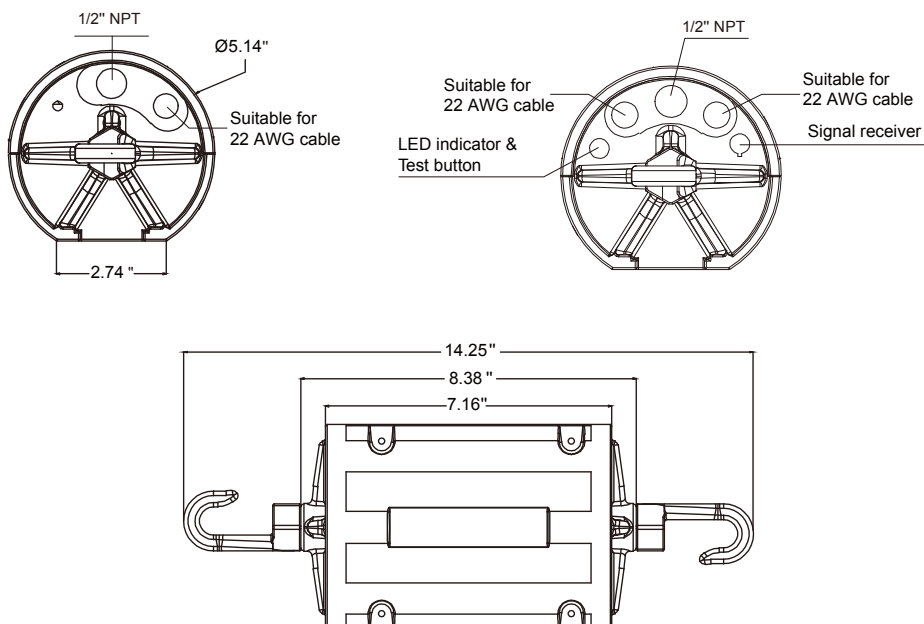

\*Available via Special Order. Call 1-800-624-4488.



# UFO LED HIGH BAY

## SELECTABLE TABLE

SKU	Wattage	CCT	Lumens	LPW
PLT-13005	200W	3000K	28,000	140
		4000K	32,000	160
		5000K	30,000	150
	220W	3000K	29,700	135
		4000K	34,100	155
		5000K	31,900	145
	240W	3000K	31,200	130
		4000K	37,200	155
		5000K	34,800	145