



COLOR/WATTAGE SELECTABLE LED STRIP FIXTURE SAFETY AND INSTALLATION INSTRUCTIONS

⚠ WARNING

- Before installing, servicing, or performing routine maintenance upon this equipment, follow these general precautions.
- To reduce the risk of death, personal injury, or property damage from fire, electric shock, falling parts, cuts/abrasions, and other hazards, read all warnings and instructions included with and on the fixture box and all fixture labels.
- Proper grounding is required to ensure safety.
- Power must be turned off at the breaker before installation or maintenance.
- This product must be installed in accordance with the applicable installation code by a person familiar with the construction and operation of the product and the hazards involved.
- Wear gloves and eye protection at all times while installing, servicing, or performing maintenance on the luminaire, and avoid direct eye exposure to the light source while it is on.
- Do not install damaged product. Inspect luminaire for damage that may have occurred during transit. If damaged, contact the manufacturer immediately.
- These instructions do not purport to cover all details or variations in equipment nor to provide every possible contingency to meet in connection with installation, operation, or maintenance. Should further information be desired or should particular problems arise which are not covered sufficiently for the purchaser's or owner's purposes, contact the manufacturer.

⚠ ADVERTENCIA

- Antes de instalar, reparar o realizar el mantenimiento de rutina de este equipo, siga estas precauciones generales.
- Para reducir el riesgo de muerte, lesiones personales o daños a la propiedad por fuego, descarga eléctrica, caída de piezas, cortes / abrasiones y otros peligros, lea todas las advertencias y instrucciones incluidas con y en la caja del dispositivo y todas las etiquetas del dispositivo.
- Se requiere una conexión a tierra adecuada para garantizar la seguridad.
- Se debe apagar la energía en el disyuntor antes de la instalación o el mantenimiento.
- Este producto debe ser instalado de acuerdo con el código de instalación aplicable por una persona familiarizada con la construcción y operación del producto y los peligros involucrados.
- Utilice guantes y protección para los ojos en todo momento durante la instalación, el servicio o el mantenimiento de la luminaria, y evite la exposición directa de los ojos a la fuente de luz mientras está encendida.
- No instale un producto dañado. Inspeccione la luminaria en busca de daños que puedan haber ocurrido durante el tránsito. Si está dañado, comuníquese con el fabricante de inmediato.
- Estas instrucciones no pretenden cubrir todos los detalles o variaciones en el equipo ni proporcionar todas las posibles contingencias a cumplir en relación con la instalación, operación o mantenimiento. Si desea obtener más información o si surgen problemas particulares que no están suficientemente cubiertos para los propósitos del comprador o propietario, comuníquese con el fabricante.

⚠ AVERTISSEMENT

- Avant d'installer, d'entretenir ou d'effectuer une maintenance de routine sur cet équipement, veuillez suivre ces précautions générales.



COLOR/WATTAGE SELECTABLE LED STRIP FIXTURE SAFETY AND INSTALLATION INSTRUCTIONS

- Pour réduire le risque de décès, de blessures corporelles ou de dommages matériels dus à un incendie, un choc électrique, des chutes de pièces, des coupures/abrasions et d'autres dangers, lisez tous les avertissements et les instructions inclus avec et sur la boîte du luminaire et toutes les étiquettes des luminaires.
- Une mise à la terre appropriée est requise pour assurer la sécurité.
- L'alimentation doit être coupée au niveau du disjoncteur avant l'installation ou l'entretien de cet équipement.
- Ce produit doit être installé conformément au code d'installation applicable par une personne familière avec la construction et le fonctionnement du produit et les risques impliqués
- Portez des gants et des lunettes de protection à tout moment lors de l'installation, de l'entretien ou de la maintenance du luminaire, et évitez de regarder directement la source lumineuse lorsqu'elle est allumée.
- N'installez pas de produit endommagé. Inspectez le luminaire pour vérifier s'il présente des dommages qui ont pu se produire pendant le transport. S'il est endommagé, contactez immédiatement le fabricant.
- Ces instructions ne prétendent pas couvrir tous les détails ou variations de l'équipement ni fournir toutes les éventualités possibles que vous pourriez rencontrer en rapport avec l'installation, l'exploitation ou la maintenance. Si vous souhaitez des informations supplémentaires ou si des problèmes particuliers surviennent et qu'ils ne sont pas suffisamment couverts pour les besoins de l'acheteur ou du propriétaire, contactez le fabricant.

WARNING

- Account for small parts and destroy packing material, as these may be hazardous to children.
- Risk of burn. Disconnect power and allow fixture to cool before handling fixture.

CAUTION

- Do not make or alter any open holes in an enclosure of wiring or electrical components during kit installation.
- Verify that supply voltage is correct by comparing it with the luminaire label information.
- All wiring connections should be capped with UL approved wire connectors.
- Green ground screw provided in proper location. Do not relocate.
- Minimum 90°C supply conductors.

NOTICE

- Specifications and dimensions subject to change without notice.



Installation Instructions

Surface Mounting

1. Take out the light fixture and accessories package from the box.

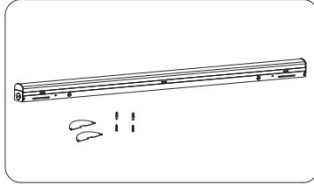

2. Attach the junction box covers to the fixture.

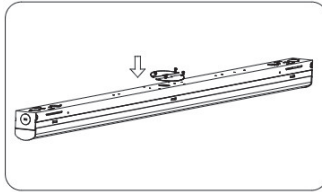

3. Separate the module board from the fixture base.

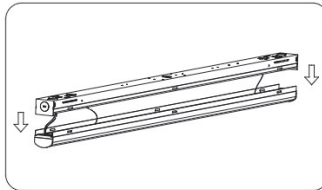

4. Secure the fixture to the ceiling with the provided plastic sleeve and screws.

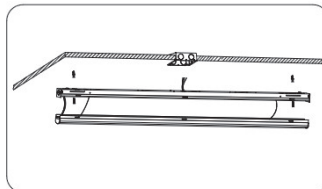



COLOR/WATTAGE SELECTABLE LED STRIP FIXTURE SAFETY AND INSTALLATION INSTRUCTIONS

- Wire to the main supply power through the junction box.

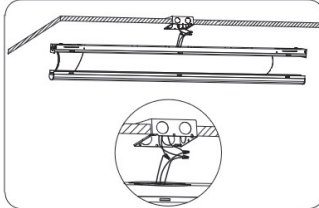

- Reattach the module board to the fixture base to finish the installation.

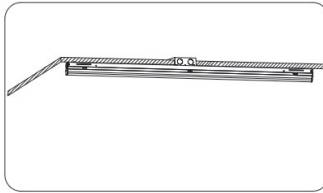

General Wiring Diagram(CCT adjustable)

2/3/4FT fixtures

Emergency CCT is 5000K when the DIP switch is set to the left or right.

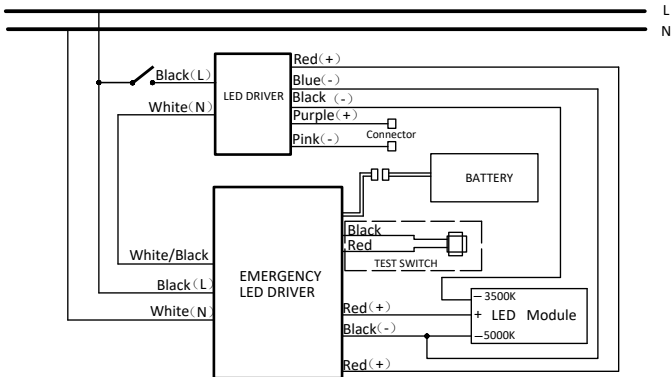



COLOR/WATTAGE SELECTABLE LED STRIP FIXTURE

SAFETY AND INSTALLATION INSTRUCTIONS

General Wiring Diagram(CCT adjustable)

8FT fixtures

Emergency CCT is the same as the fixture's default CCT.

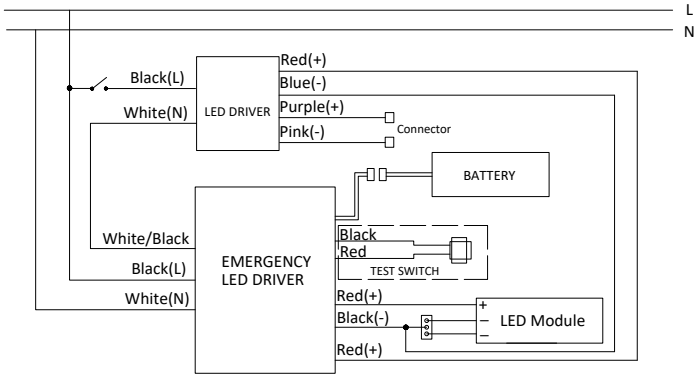



Field-Adjustable Wattage & CCT

The end users may adjust the color temperature and lumen output respectively by the two DIP Switches. Each DIP switch is accommodated with 3 options (left, middle, and right), corresponding to 3 color temperatures and 3 wattages respectively, which can perform the desired color temperature and lumen output combination.

Factory Settings:

- PLT-90357 – 5000K, 30W
- PLT-90358 – 5000K, 45W
- PLT-90359 – 5000K, 54W
- PLT-90360 – 5000K, 90W

1. DIP switches are located on the driver box.
2. Select a wattage and color temperature by sliding the switch left or right respectively to the desired value.

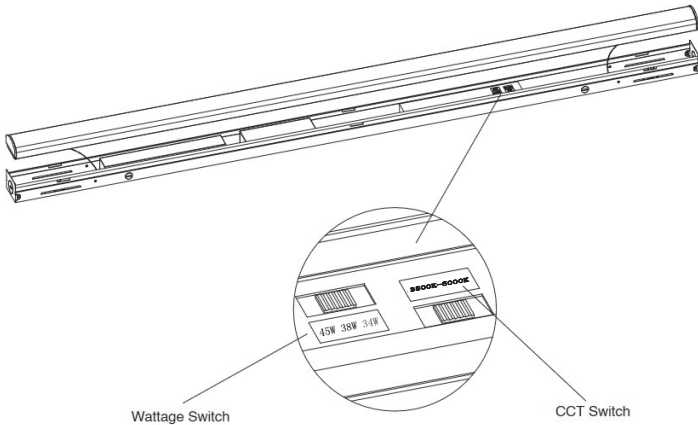



COLOR/WATTAGE SELECTABLE LED STRIP FIXTURE

SAFETY AND INSTALLATION INSTRUCTIONS

EM Installed Fixture

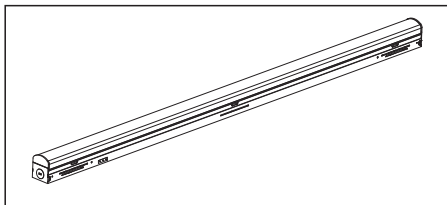

TEST SWITCH INDICATOR STATUS:

LED Indicators Status	EM Driver Status/Mode
• Solid Green	• System OK/AC OK
• Red indicator flashing, 4S ON, 1S OFF	• Low battery voltage,Self-Diagnostic failed
• Green indicator, 1S ON, 1S OFF	• Self-Diagnostic mode
• The indicators light OFF	• Power grid turn off,Emergency mode
• Alternate brightness of red and green,1S RED,1S GREEN	• Load Open
• Red indicator flashing, 1S ON, 1S OFF	• Load short,Self-Diagnostic mode
• Alternate brightness of red and green,4S RED,1S GREEN	• Self-Diagnostic and the output current exceeds 25% of the rated value

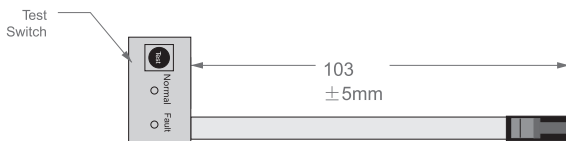

Self-Diagnostic mode

- 1.Each month auto self diaganostic
- 2.Each Year auto self diaganostic 90 mintues

Self-Diagnostic Mode Enable and Disable operation method

Dip Switch enable position and Learned LED load will enable Self-Diagnostic function .

"ENABLE" is the default setting. Move Dip Switch to "DISABLE" if Self-Diagnostic functionality is not desired.

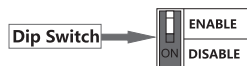

Recharge time

-12hours

Operation time

-90 minutes with 1000-1500 lumens output

The fixture can be switched off by connected wall switch. When emergency conditions (main power off), use wall switch to turn on the fixture which will be running in emergency mode.



COLOR/WATTAGE SELECTABLE LED STRIP FIXTURE SAFETY AND INSTALLATION INSTRUCTIONS

PLEASE READ CAREFULLY AND FOLLOW ALL INSTRUCTIONS FOR YOUR OWN SAFETY

- **IMPORTANT:** An un-switched AC power source of 100VAC to 277VAC is required for the black and white leads.
- **IMPORTANT:** A switched or un-switched AC power source of 100VAC to 277VAC is acceptable for the black lead only.
- This device is designed for use in fixtures listed for **damp location**.
- **CAUTION:** Do not use outdoors.
- **CAUTION:** The use of accessory equipment not recommended by the manufacturer may cause an unsafe condition.
- **CAUTION:** Make sure all electrical connections conform to the National Electrical Code and all applicable local regulations.
- **CAUTION:** Do not mount near gas or electric heaters.
- **CAUTION:** Do not use this emergency driver with accessory equipment other than recommended by manufacturer; failure to follow this may cause an unsafe condition. Servicing should only be performed by qualified service personnel.
- **CAUTION:** Do not use this emergency driver for other than intended use.
- **CAUTION:** Battery is rechargeable LiFePo4 type and must be recycled or disposed of properly.
- **CAUTION:** Equipment should be mounted in locations and at heights where it will not readily be subjected to tampering by unauthorized personnel.

SAVE THESE INSTRUCTIONS

TESTING SYSTEM: The emergency battery requires a minimum charge time of one (1) hour before testing the circuit. A minimum of twelve (12) hours is required for a full charge.

IMPORTANT: In order to maintain proper operation and warranty coverage, the battery must be recharged once per year prior to installation.

RATED EMERGENCY OPERATION: Ninety (90) minutes for the 10W load

Max. mounting height: _ 17.7 _ ft (_ 5.39 _ m) " or the equivalent.

Model: HT-EM-10W-120-277-FT-XXXX

Associated Target Luminaire: E484679 (PRECISION LIGHTING&TRANSFORMER, INC.), Model PLT-90357, PLT-90358, PLT-90359 and PLT-90360, with LED model BXEN-49E-11M-3AA, made by Bridgelux