



# PLT Wattage and Color Selectable LED Cutoff Wall Pack Spec Sheet



## ► DESCRIPTION

Traditional 35W-120W Semi-Cutoff LED Wall Pack | 120-277V | 4000/5000K Selectable | Glass Lens

## ► APPLICATION

Building Mount for exterior illumination (perimeters, pathways, loading docks, and other general security lighting requirements)





# PLT Wattage and Color Selectable LED Cutoff Wall Pack Spec Sheet

## PRODUCT FEATURES

- Up to 82% energy saving compared to traditional fixtures.
- Heavy-duty die cast aluminum housing.
- Architectural bronze finish, anti-corrosion spray.
- Borosilicate glass lens for long life durability, no fading, high light transmittance.
- IP65 rated, waterproofing material is used throughout the fixture.
- DLC 5.1 Premium\*\*\*
- Dusk to dawn photocell options.
- 4000K/5000K CCT selectable; -40 Deg. to 113 Deg. F operating temperature.
- 100%/80%/60% wattage selectable.
- 5 Years warranty.

\*Optional finishes available via Special Order. Call 1-800-624-4488.

\*\*See Selectable Table on Page 5 for full breakdown.

\*\*\*See Page 5 for full list of DLC part numbers.

## ELECTRICAL SPECIFICATIONS

Catalog Number	Photocell	Wattage	Lumens**	Dimming	CCT	Efficacy**	CRI	Housing Color	Input Voltage	LED L70 Life Hours	Wattage Equivalent
PLT-12999 PLT-13000	Yes	21W/ 28W/ 35W	Up to 4800 lm	No	4000K	Up to 149 lm/W	>80	Bronze	120-277V	100,000 hrs	175W MH
	No				5000K			Black*			
					White*						
PLT-12997 PLT-12998	Yes	30W/ 40W/ 50W	Up to 6900 lm	No	4000K	Up to 149 lm/W	>80	Bronze	120-277V	100,000 hrs	250W MH
	No				5000K			Black*			
					White*						
PLT-12995 PLT-12996	Yes	45W/ 60W/ 75W	Up to 10,500 lm	No	4000K	Up to 146 lm/W	>80	Bronze	120-277V	100,000 hrs	250W MH
	No				5000K			Black*			
					White*						
PLT-13002	No	60W/ 80W/ 100W	Up to 14,000 lm	No	4000K	Up to 147 lm/W	>80	Bronze	120-277V	100,000 hrs	400W MH
					5000K			Black*			
					White*						
PLT-13001	No	72W/ 96W/ 120W	Up to 16,800 lm	No	4000K	Up to 147 lm/W	>80	Bronze	120-277V	100,000 hrs	400W MH
					5000K			Black*			
					White*						



# PLT Wattage and Color Selectable LED Cutoff Wall Pack Spec Sheet

## DIMENSIONS

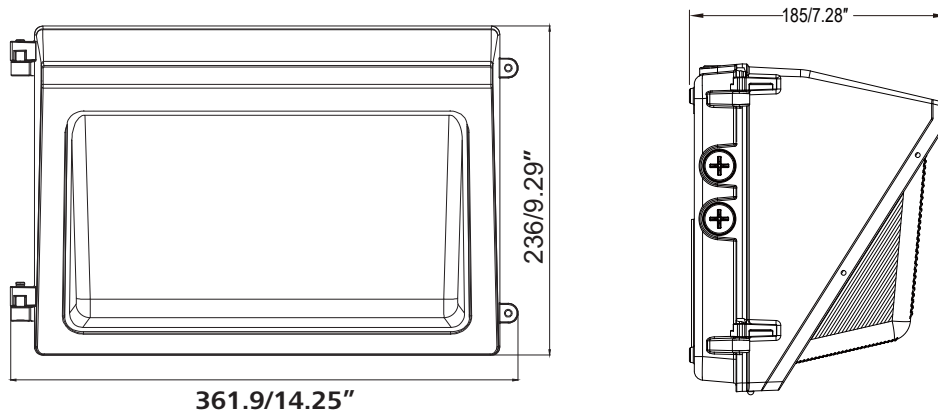

35W/50W/75W/100W/120W

## PHOTOMETRICS

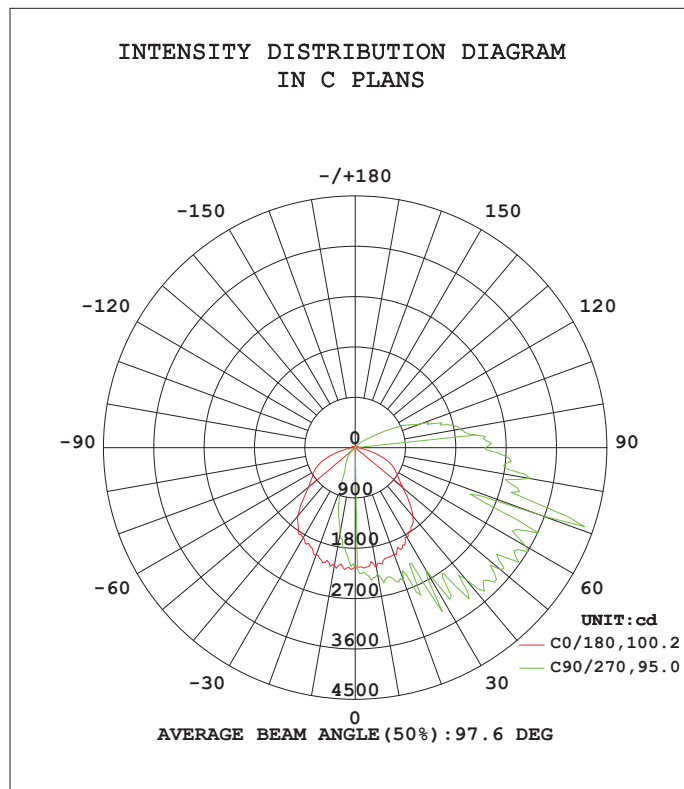



# PLT Wattage and Color Selectable LED Cutoff Wall Pack Spec Sheet

## INSTALLATION REFERENCE



## ACCESSORIES



Emergency battery back-up

Model NO.	Output Voltage	Emergency Power	Battery Type	For Models
NPS-00189*	81~155Vdc	8W	Li-ion/ Ni-MH	35W-75W
NPS-00188*		15W		100W-120W

\*Available via Special Order. Please call 1-800-624-4488.



# PLT Wattage and Color Selectable LED Cutoff Wall Pack Spec Sheet

## SELECTABLE TABLE

SKU	Wattage	CCT	Lumens	LPW
PLT12999 & PLT-13000	35	5000K	4800lm	137lm/w
	35	4000K	4700lm	136lm/w
	28	5000K	3900lm	139lm/w
	28	4000K	3800lm	136lm/w
	21	5000K	3200lm	149lm/w
	21	4000K	3100lm	147lm/w
PLT-12997 & PLT-12998	50	5000K	6900lm	138lm/w
	50	4000K	6900lm	138lm/w
	40	5000K	5500lm	137lm/w
	40	4000K	5500lm	137lm/w
	30	5000K	4500lm	149lm/w
	30	4000K	4500lm	149lm/w
PLT-12995 & PLT-12996	75	5000K	10500lm	140lm/w
	75	4000K	10300lm	137lm/w
	60	5000K	8300lm	139lm/w
	60	4000K	8200lm	138lm/w
	45	5000K	6600lm	146lm/w
	45	4000K	6500lm	144lm/w
PLT-13002	100	5000K	14000lm	140lm/w
	100	4000K	13900lm	139lm/w
	80	5000K	11000lm	138lm/w
	80	4000K	10900lm	136lm/w
	60	5000K	8800lm	147lm/w
	60	4000K	8700lm	145lm/w
PLT-13001	120	5000K	16800lm	140lm/w
	120	4000K	16700lm	139lm/w
	96	5000K	13200lm	138lm/w
	96	4000K	13100lm	137lm/w
	72	5000K	10500lm	147lm/w
	72	4000K	10400lm	145lm/w

## DLC Part Numbers

SKU	DLC Level	DLC #
PLT-12995	5.1 Premium	PLTBD36P
PLT-12996	5.1 Premium	PLTBD36
PLT-12997	5.1 Premium	PLTBD26P
PLT-12998	5.1 Premium	PLTBD26
PLT-12999	5.1 Premium	PLTBD16P
PLT-13000	5.1 Premium	PLTBD16
PLT-13001	5.1 Premium	PLTBD56
PLT-13002	5.1 Premium	PLTBD46