



LED Tape Light Channel – Surface Mount

DESCRIPTION

Create custom fixtures for your LED tape light with these surface channels and their compatible accessories.

FEATURES

- Comes with opaque lens
- Channel and lens can be cut to desired length
- Designed for LED tape light no wider than 12mm/0.47 in
- Requires additional accessories to complete installation; see Accessories section for full list of compatible accessories.

LISTINGS

- Indoor/dry locations
- RoHS

CONSTRUCTION

- Aluminum with either black or anodized finish
- Frosted PC lens protects the tape light while diffusing light output

INSTALLATION

- Surface mount to flat surface with mounting clips (sold separately); see Installation Instructions for more information.

WARRANTY

- 3-year limited warranty; see pltsolutions.com for warranty details

Project name	Type
Catalog number	
Comments	Voltage
Approved by	Date



APPLICATIONS

- Display Cases
- Covers
- Under Cabinets
- Shelves
- Staircases

PERFORMANCE SUMMARY

Item #	Mounting	Beam Angle	Tape Light Max. Width	Finish	Length
PLT-12847	Surface	100°	12mm	Black	6.6'
PLT-12848	Surface	100°	12mm	Anodized	6.6'

ACCESSORIES

SKU	Description	Compatible With
PLT-12849	End Cap - Grey - 2 Pack	PLT-12848
PLT-12850	End Cap - Black - 2 Pack	PLT-12847
PLT-12851	90 Deg. Plastic Joiner - 2 Pack	PLT-12847, PLT-12848
PLT-12852	180 Deg. Plastic Joiner - 2 Pack	PLT-12847, PLT-12848
PLT-12853	Adjustable Bracket with Mounting Clip	PLT-12847, PLT-12848
PLT-12854	Metal Mounting Clip	PLT-12847, PLT-12848
PLT-12855	Clear Mounting Clip	PLT-12847, PLT-12848

INSTALLATION

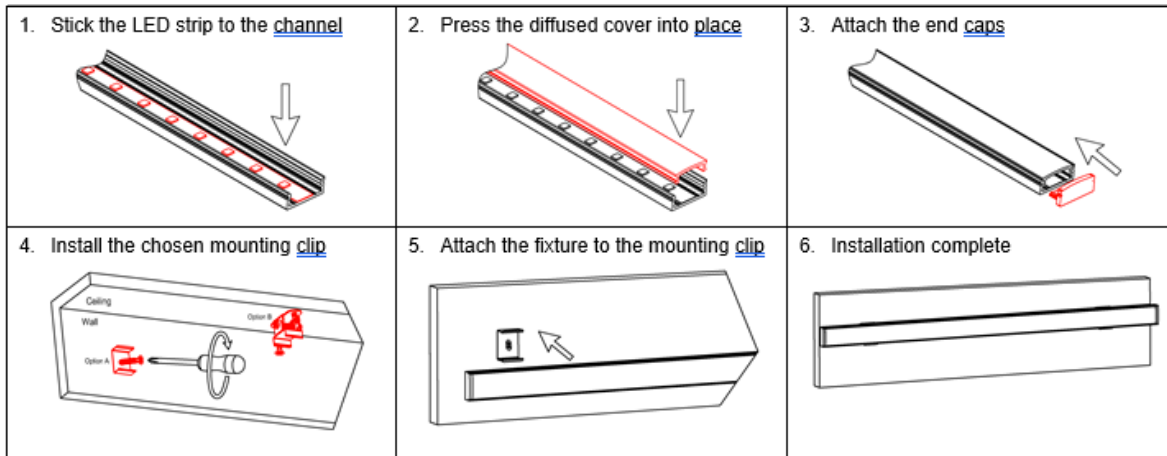

DIMENSIONS

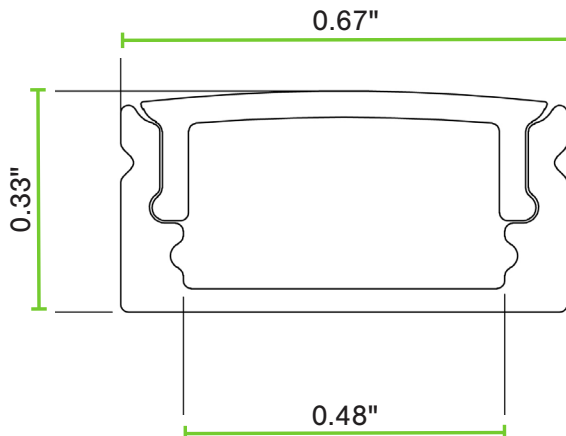

CHANNEL

Height - 0.33"

Width - 0.67"

Inner Channel Width - 0.48"

Length - 6.6'

Weight - 0.6 lbs