



LED Tape Light Channel – Surface Mount

DESCRIPTION

Create custom fixtures for your LED tape light with these surface channels and their compatible accessories.

FEATURES

- Comes with opaque lens
- Channel and lens can be cut to desired length
- Designed for LED tape light no wider than 15mm/0.59 in
- Requires additional accessories to complete installation; see Accessories section for full list of compatible accessories.

LISTINGS

- Indoor/dry locations
- RoHS

CONSTRUCTION

- Aluminum with either black or anodized finish
- Frosted PC lens protects the tape light while diffusing light output

INSTALLATION

- Surface mount to flat surfaces with mounting clips (sold separately); see Installation Instructions for more information.

WARRANTY

- 3-year limited warranty; see pltsolutions.com for warranty details

Project name	Type
Catalog number	
Comments	Voltage
Approved by	Date



APPLICATIONS

- Display Cases
- Covers
- Under Cabinets
- Shelves
- Staircases



PERFORMANCE SUMMARY

Item #	Mounting	Beam Angle	Tape Light Max. Width	Finish	Length
PLT-12877	Surface	100°	15mm	Black	6.6'
PLT-12878	Surface	100°	15mm	Anodized	6.6'

ACCESSORIES

SKU	Description	Compatible With
PLT-12879	End Cap - Grey - 2 Pack	PLT-12678
PLT-12880	End Cap - Black - 2 Pack	PLT-12877
PLT-12866	Metal Mounting Bracket	PLT-12862, PLT-12863, PLT-12873, PLT-12874, PLT-12877, PLT-12878
PLT-12867	45 Deg. Metal Mounting Bracket	PLT-12862, PLT-12863, PLT-12873, PLT-12874, PLT-12877, PLT-12878
PLT-12868	Adjustable Bracket with Mounting Clip	PLT-12862, PLT-12863, PLT-12873, PLT-12874, PLT-12877, PLT-12878

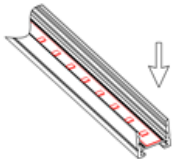
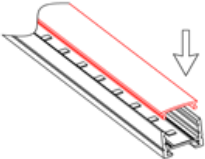
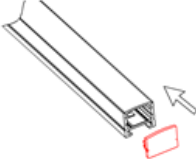
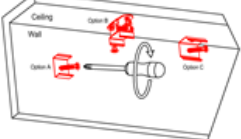
INSTALLATION

<p>1. Stick the LED strip to the channel.</p> 	<p>2. Press the diffused cover into place.</p> 	<p>3. Click the end caps</p> 
<p>4. Install the chosen mounting clips.</p> 	<p>5. Attach the fixture to the mounting clips.</p> 	<p>6. Installation complete.</p> 

DIMENSIONS

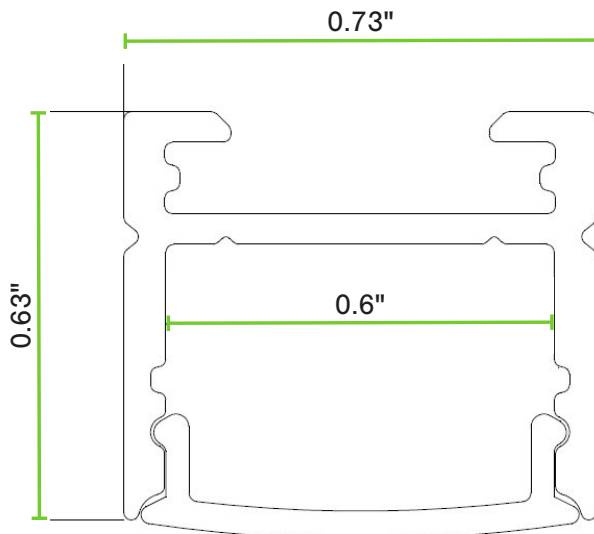

CHANNEL

Height - 0.63"

Width - 0.73"

Inner Channel Width - 0.6"

Length - 6.75'

Weight - 1.04 lbs