

CATALOG NUMBER: E-SZA0DD150 FOR ONE 150 WATT, S55 HIGH PRESSURE SODIUM LAMP

Line Voltage	480V
Regulation	
Line Volts	+/- 5%
Lamp Watts	WITHIN TRAPEZOID
Frequency	60 Hz
Circuit Type	HX-HPF
Power Factor (min)	90%
Insulation Class	H(180°)
Min. Ambient Starting Temp.	-40° F or -40° C

Line Voltage (Volts)	480
Line Current (Amps)	
Operating	0.44
Open Circuit	0.80
Starting	0.50
Input Watts (W)	188
Open Circuit Voltage (V)	120
Drop Out Voltage (V)	384
UL(1029) Bench Top Rise	E
Recommended Fuse (Amps)	2
HIGH POTENTIAL TEST (VOLTS)	
1 Minute	2000
2 Seconds	2500
Open Circuit Voltage Test(volts)	110-135
Short-Circuit Current Test (Amps)	
Secondary Current	3.6 - 4.6
Input Current (Amps)	0.25 - 0.40

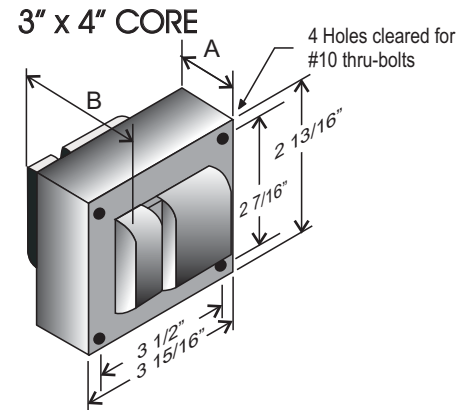

CORE AND COIL

Dimension A (inches)	3.00
Dimension B (inches)	4.00
Weight (Lbs)	9.00
Lead Lengths (inches)	12

CAPACITOR

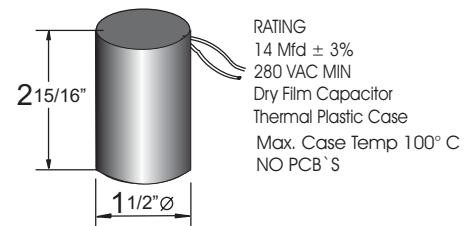

IGNITOR 37-63-AS-9.1-N7
Ballast to Lamp Distance (BTL): 2 feet

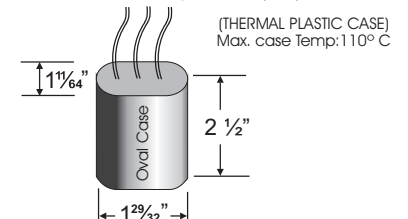

BRACKET
CORE & COIL
MOUNTING BRACKET

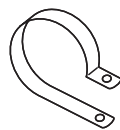
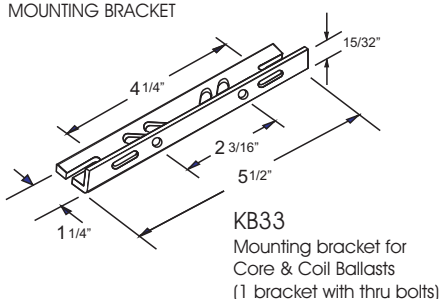

C-01
MOUNTING CLIP for round
case (Furnished as standard
with B suffix ballast)

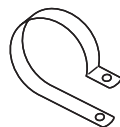

I-01
MOUNTING CLIP for oval
case (Furnished as standard
with B suffix ballast)

WIRING DIAGRAM

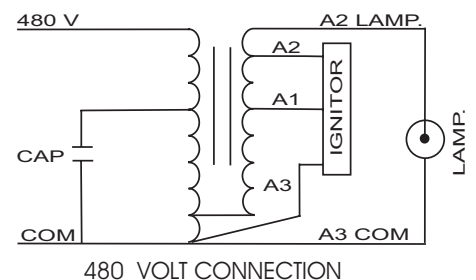

ORDERING INFORMATION

*** Add proper suffix to catalog number when ordering as indicated below:
No suffix = Core and Coil Only
B= Core and Coil, and Bracket
C=Core and Coil, and Capacitor
BC=Core and Coil, Capacitor and Bracket

Data is based upon tests performed by Industrias Sola Basic in a controlled environment and representative of relative performance. Actual Performance can vary depending on operating conditions. Specifications are subject to change without notice.

ISO 9001:2000



Made in Mexico by Industrias Sola Basic S.A de C.V.