



Questions?

For customer service please call us at 1-310-787-1100
Office Hours: 8:00 a.m. – 5:00 p.m. PST Monday-Friday
E-mail: info@eurilighting.com



LED Linear Suspended
Up & Down light

PLEASE REVIEW THE INSTRUCTIONS AND WARNINGS LISTED BELOW PRIOR TO PROPER INSTALLATION

WARNINGS

- This product must be installed in accordance with the applicable installation code by a person familiar with the construction and operation of the product and hazards involved
- Risk of fire or electric shock. LED lamp installation requires knowledge of luminaries electrical systems. If not qualified, do not attempt installation. Contact a qualified electrician.
- Use in dry locations only.
- This lamp supports dimming function, must use with dimmers.
- Small noises when shaking does not affect the quality.

INSTRUCTIONS

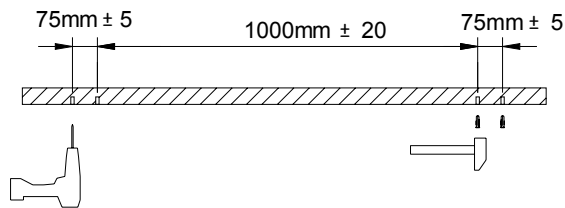

1 Drill a hole of 5.0mm in diameter as shown in the figure at the location required for installation. Then hammer the plastic anchor into the hole.

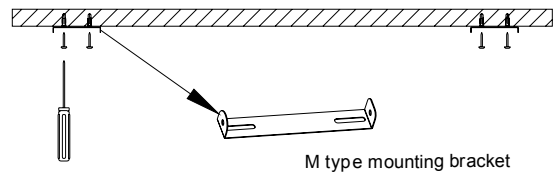

2 Insert PA4*35 screws into the M-type mounting bracket and then drill into the plastic anchor.

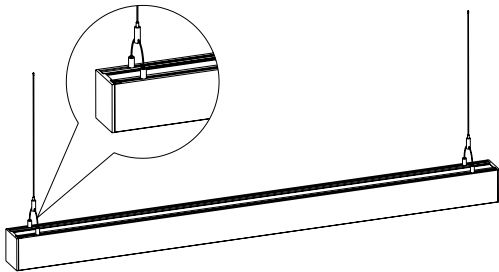

3 Rotate and fasten 2 fixing heads and 2 screws of left end; hold steel wire rope and lift lamp upward, then adjust balance screws to balance light, finally tighten balance screws.

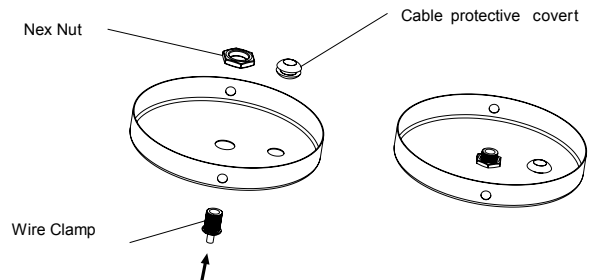

4 Insert the wire clamp into the middle hole of the disc and tighten the wire clamp with hex nut; Clip the cable protective cover into the AC line hole of the disc.

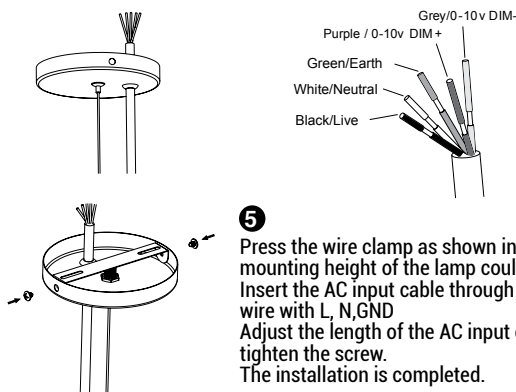

5 Press the wire clamp as shown in the figure, and then insert the stainless steel wire into the inner hole of the wire clamp; The mounting height of the lamp could be adjusted by this wire clamp. Insert the AC input cable through the cable protective cover and connect it with the AC line by the corresponding connection wire with L, N, GND. Adjust the length of the AC input cable, align the side holes of the disc and the mounting bracket as shown in the figure, then tighten the screw. The installation is completed.

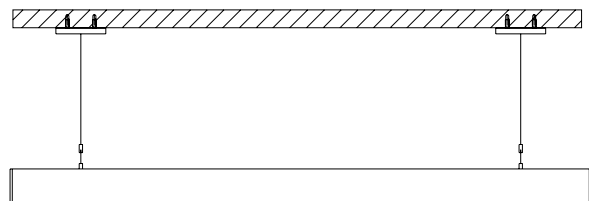



Questions?

For customer service please call us at 1-310-787-1100
Office Hours: 8:00 a.m. – 5:00 p.m. PST Monday-Friday
E-mail: info@eurilighting.com



LED Linear Suspended
Up & Down light

PLEASE REVIEW THE INSTRUCTIONS AND WARNINGS LISTED BELOW PRIOR TO PROPER INSTALLATION

OPERATING GUIDE - CCT ADJUSTABLE

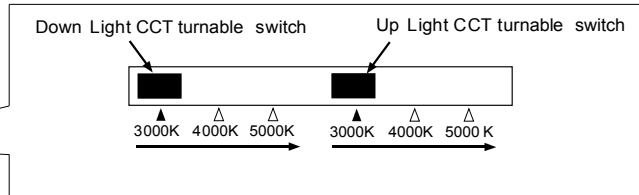
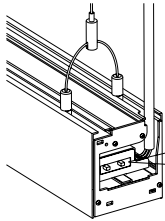

Open the end cap the side with AC wire as the picture shows. Moving the Dip to choose the CCT or you want as the label shows.

LINKABLE INSTRUCTION - CONNECTION INSTALLATION

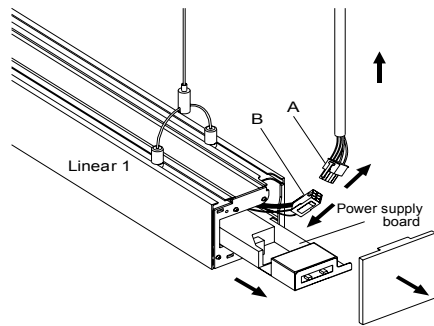

1 Install the Linear 1 to the ceiling as instruction of Suspension Installation. Open the end cap as the picture shows. Pull out 1/2 Power supply board of Linear, and move out the ac wires. Disconnect the A and B parts.

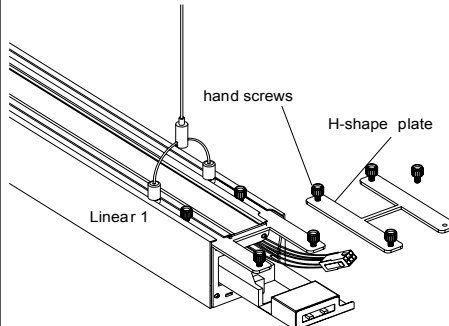

2 Insert the H-shape plate to the track as the picture shows.

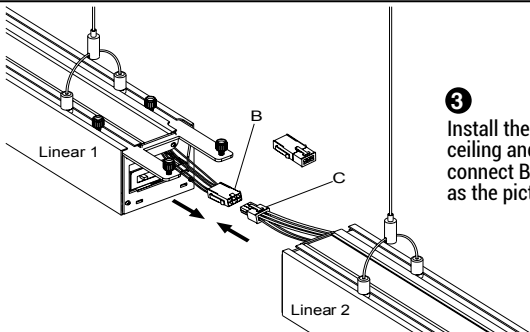

3 Install the Linear 2 to the ceiling and open the end cap, connect B and C as the picture shows.

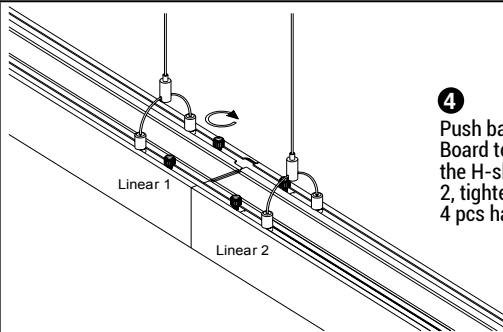

4 Push back Power Supply Board to Linear 1 then insert the H-shape plate to Linear 2, tighten the plate with 4 pcs hand screws.

Install the Linear Light as above method, keep one main input cord on one side.

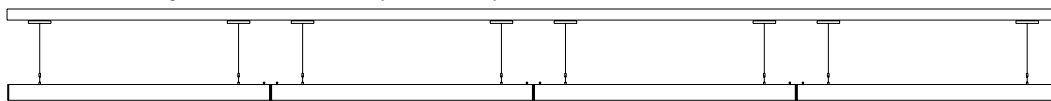

Note:
For safety standard, please do not connect more than 4pcs 4ft LED lamp in a row; do not connect more than 3 pcs 8ft LED lamp in a row.

ACCESSORIES BAG INCLUDES

