

DESCRIPTION

Improve security lighting around building perimeters by replacing existing metal halide fixtures with these more efficient LED wall packs.

FEATURES

- Delivers up to 135 LPW
- Replaces 150W and 175W metal halide fixtures
- 0-10V dimming

LISTINGS

- IP65 Rated
- UL Listed
- DesignLights Consortium® 5.1 Premium - meets the requirements for the highest DLC qualification for efficacy and lumen maintenance

PERFORMANCE

- CRI: 70
- CCT: 5000K
- LED L70 Life Hours: ≥100,000 hours

ELECTRICAL

- THD: <20%
- Power Factor: >0.9
- Input Voltage: 120-277V
- Surge protection: 4kV

THERMAL

- -40°F to 113°F (-40°C to 45°C) operating temperature

CONSTRUCTION

- Heavy duty die-cast aluminum housing with bronze finish and anti-corrosion spray
- Durable borosilicate glass lens doesn't fade and allows high light transmittance

WARRANTY

- 5 year limited warranty; see pltsolutions.com for warranty details

project name	type
catalog number	
comments	voltage
approved by	date



APPLICATIONS

- General Security Lighting
- Pathways
- Loading Docks
- Building Perimeters

PERFORMANCE SUMMARY

Item #	Watts	Lumens	LPW	CRI	CCT	Lens	Dimming	Voltage	Replaces	DLC #	DLC Level
PLTS-12362	35W	4725	135	70	5000K	Glass	0-10V	120-277V	MH150	PLTBN1311	5.1 Premium
PLTS-12363	50W	6750	135	70	5000K	Glass	0-10V	120-277V	MH175	PLTBN2311	5.1 Premium

INSTALLATION HEIGHT REFERENCE



DIMENSIONS

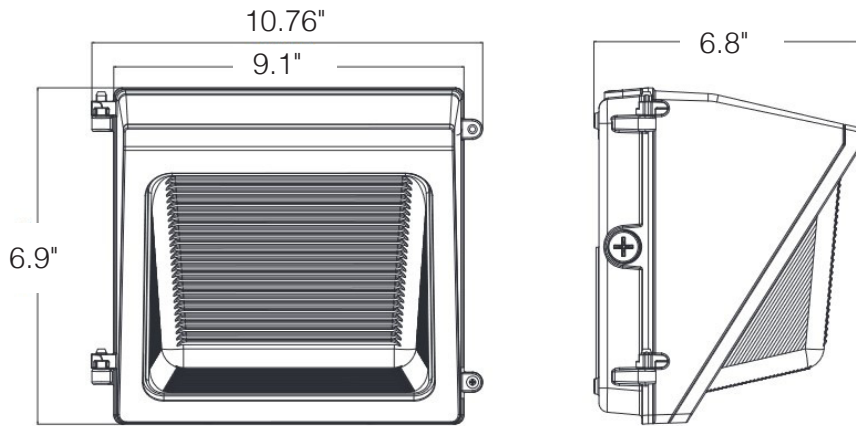

DIMENSIONS

- Height: 6.9"
- Width: 9.1"
- Width w/ hinges: 10.76"
- Depth: 6.8"
- Weight: 3.55 lbs

PHOTOMETRICS

35W

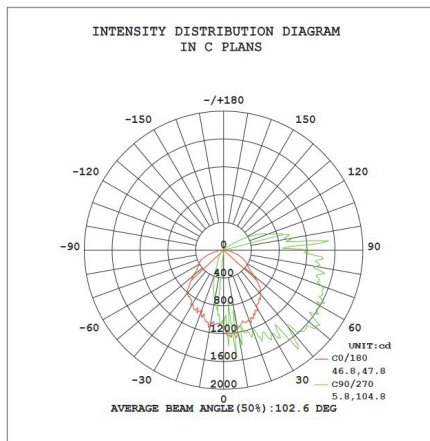

50W

