

## Features & Specifications

**INTENDED USE** – PLT ceiling LED troffer fixtures combine LED technology along with outstanding optical performance to seamlessly replace fluorescent troffers in offices or other commercial applications. The new PLT LED Architectural PLTM6 LED fixture adopts the latest in optical and LED technology for use in many commercial applications. The PLTM6 LED provides a single pleasant volumetric soft light that fills any interior space, giving it a larger, brighter, and more productive ambiance while it uses a fraction of the power consumption, last years longer and completely eliminate the need for tubes, sockets, and ballasts for excellent cost savings.

**CONSTRUCTION** – Sealed housing prevents dust and debris build-up within the panel making this a cleaner fixture option for sanitary locations such as hospitals, clinics, dental offices, testing rooms, labs and more.

**OPTICS** – High-Performance Integrated LEDs maintain a 2660 to 3840 Lumen output at 3500K, 4000K, or 5000K for LED L70 100,000 life hours of use. ≥80 CRI. Unique optics guide plate controls glare and provides uniform light distribution through a smooth opaque acrylic lens for an even and consistent shadow-less light.

**ELECTRICAL** – Equipped standard with a 0-10V continuous dimming driver that works with any standard 0-10V control/dimmer, input voltage of 120-277 VAC. 50/60Hz. Temperature range of -20 Deg. C to 50 Deg. C.

LED drivers eliminate the issues commonly associated with ballast driven fixtures such as humming, flickering, and failures.

**INSTALLATION** – The lightweight troffer fixture weigh only 7.7 pounds, reducing labor costs by supporting one-man installations. These LED troffers are remarkably easy to install. Once the integrated LED driver has been properly wired, tabs on the back of the fixture must be bent for the fixture to hang directly from the drop ceiling.

**LISTINGS** – Built to UL 1598 and 8750 standards. DLC 5.1 Standard / DLC Part Number - PLTM62111

**WARRANTY** – 5-year warranty. PLT products that are damaged or defective will be repaired or replaced at PLT's choosing for a period of 5 years. Contact 1-800-624-4488 for more information.

**ADD-ONS** – Pair with motion sensors, timers, and daylight harvesting systems for hassle free energy savings during the day without needing to worry about manually turning the fixture on and off. Use in conjunction with any 0-10V LED dimmer control to customize lighting level and maximize energy savings. Emergency battery backups are available to ensure up to 90 minutes of lighting in the event of an outage. For more versatile installation options, suspension, surface and recessed mounting kits are available. If using a conventional motion sensor, be sure to replace it with one rated for use with LEDs. While conventional light sensors will still work with LED fixtures at first, they will burn out prematurely. The same is true for motion sensors.

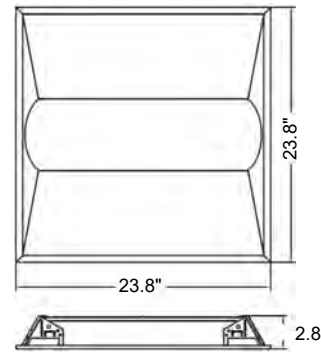

**Dimensions**  
 Length: 23.8 in.  
 Width: 23.8 in.  
 Height: 2.8 in.  
 Weight: 7.7 lbs

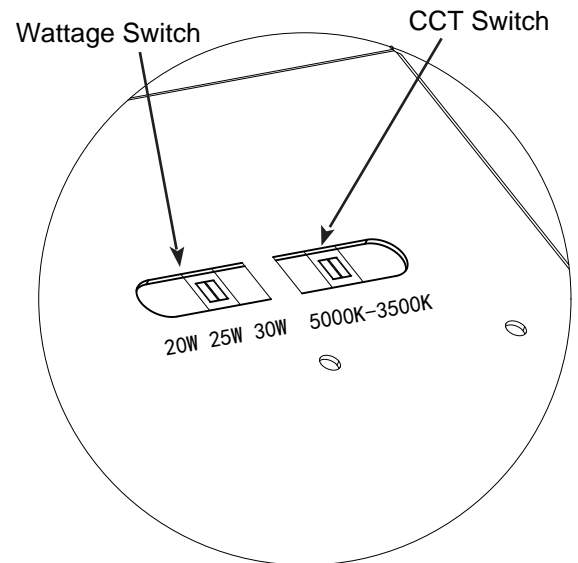

SKU #	Kelvin	Lumens	CRI	Wattage	Voltage	DLC?	Mounting	LED L70 Life Hours	Warranty
PLT-90190	3500K	2660-3840	80	25	120-277V	YES	Recessed	100,000	5 Years
	4000K			25					
	5000K			30					