



⚠ WARNING

- Before installing, servicing, or performing routine maintenance upon this equipment, follow these general precautions.
- To reduce the risk of death, personal injury, or property damage from fire, electric shock, falling parts, cuts/abrasions, and other hazards, read all warnings and instructions included with and on the fixture box and all fixture labels.
- Proper grounding is required to ensure safety.
- Power must be turned off at the breaker before installation or maintenance.
- Installation, service, and maintenance of luminaires should be performed by a qualified licensed electrician.
- Wear gloves and eye protection at all times while installing, servicing, or performing maintenance on the luminaire, and avoid direct eye exposure to the light source while it is on.
- Do not install damaged product. Inspect luminaire for damage that may have occurred during transit. If damaged, contact the manufacturer immediately.
- These instructions do not purport to cover all details or variations in equipment nor to provide every possible contingency to meet in connection with installation, operation, or maintenance. Should further information be desired or should particular problems arise which are not covered sufficiently for the purchaser's or owner's purposes, contact the manufacturer.

⚠ ADVERTENCIA

- Antes de instalar, reparar o realizar el mantenimiento de rutina de este equipo, siga estas precauciones generales.
- Para reducir el riesgo de muerte, lesiones personales o daños a la propiedad por fuego, descarga eléctrica, caída de piezas, cortes / abrasiones y otros peligros, lea todas las advertencias y instrucciones incluidas cony en la caja del dispositivo y todas las etiquetas del dispositivo.
- Se requiere una conexión a tierra adecuada para garantizar la seguridad.
- Se debe apagar la energía en el disyuntor antes de la instalación o el mantenimiento.
- La instalación, el servicio y el mantenimiento de las luminarias deben ser realizados por un electricista autorizado y calificado.
- Utilice guantes y protección para los ojos en todo momento durante la instalación, el servicio o el mantenimiento de la luminaria, y evite la exposición directa de los ojos a la fuente de luz mientras está encendida.
- No instale un producto dañado. Inspeccione la luminaria en busca de daños que puedan haber ocurrido durante el tránsito. Si está dañado, comuníquese con el fabricante de inmediato.
- Estas instrucciones no pretenden cubrir todos los detalles o variaciones en el equipo ni proporcionar todas las posibles contingencias a cumplir en relación con la instalación, operación o mantenimiento. Si desea obtener más información o si surgen problemas particulares que no están suficientemente cubiertos para los propósitos del comprador o propietario, comuníquese con el fabricante.

⚠ AVERTISSEMENT

- Avant d'installer, d'entretenir ou d'effectuer une maintenance de routine sur cet équipement, veuillez suivre ces précautions générales.



OUTDOOR POWER STAKE W/ REMOTE & TIMER

SAFETY AND INSTALLATION INSTRUCTIONS

- Pour réduire le risque de décès, de blessures corporelles ou de dommages matériels dus à un incendie, un choc électrique, des chutes de pièces, des coupures/abrasions et d'autres dangers, lisez tous les avertissements et les instructions inclus avec et sur la boîte du luminaire et toutes les étiquettes des luminaires.
- Une mise à la terre appropriée est requise pour assurer la sécurité.
- L'alimentation doit être coupée au niveau du disjoncteur avant l'installation ou l'entretien de cet équipement.
- L'installation, l'entretien et la maintenance des luminaires doivent être effectués par un électricien qualifié et agréé.
- Portez des gants et des lunettes de protection à tout moment lors de l'installation, de l'entretien ou de la maintenance du luminaire, et évitez de regarder directement la source lumineuse lorsqu'elle est allumée.
- N'installez pas de produit endommagé. Inspectez le luminaire pour vérifier s'il présente des dommages qui ont pu se produire pendant le transport. S'il est endommagé, contactez immédiatement le fabricant.
- Ces instructions ne prétendent pas couvrir tous les détails ou variations de l'équipement ni fournir toutes les éventualités possibles que vous pourriez rencontrer en rapport avec l'installation, l'exploitation ou la maintenance. Si vous souhaitez des informations supplémentaires ou si des problèmes particuliers surviennent et qu'ils ne sont pas suffisamment couverts pour les besoins de l'acheteur ou du propriétaire, contactez le fabricant.

WARNING

- Use only with outdoor equipment or seasonal decorations.
- Not for permanent use. Do not install or use this product for more than a 90-day period. If using an outdoor-use cord set for an extended period of time (greater than 90 days), please consider hard wiring a permanent, outdoor-use receptacle rated for year-round use in the area that power is needed.
- Do not exceed the maximum amperage rating of 15 Amps, or maximum wattage rating of 1,875 Watts.
- Cancer and reproductive harm – www.P65Warnings.ca.gov

CAUTION

- If using with products that are not marked with an ampere rating, connect no more than 140 screw-base lamps (C7 or C9) or 12 mini light strings to this power stake.
- This product should be plugged into a GFCI receptacle.
- Suitable for indoor and outdoor use. Store indoors while not in use.
- The connector body should be maintained a minimum of 6 inches above the ground.
- This is not a surge protector.
- Do not coil the power cord when in service.
- Failure to properly align the battery polarity in the remote can cause personal injury and/or property damage.
- Do not ingest the battery. If you think batteries might have been swallowed or placed inside any part of the body, seek immediate medical attention.
- Keep new and used batteries away from children.
- If the battery compartment does not close securely, stop using the product and keep it away from children.
- Do not expose batteries to fire or other heat sources.
- This battery contains mercury. Recycle or manage as hazardous waste. Do not put in trash.



Federal Communications Commission (FCC) Interference Statement

This equipment has been tested and found to comply with the limits for Class B digital device, pursuant to part 15 of the FCC Rules. These limits are designed to provide reasonable protection against harmful interference in a residential installation. This equipment generates, uses and can radiate radio frequency energy and, if not installed and used in accordance with the instructions, may cause harmful interference to radio or television reception, which can be determined by turning the equipment off and on, the user is encouraged to try to correct the interference by one or more of the following measures:

- Reorient or relocate the receiving antenna.
- Increase the separation between the equipment and the receiver.
- Connect the equipment into an outlet on a circuit different from that to which the receiver is connected.
- Consult the dealer or an experienced radio/ TV technician for help.

This device complies with Part 15 of the FCC Rules. Operation is subject to the following two conditions: (1) This device may not cause harmful interference, and (2) this device must accept any interference received, including interference that may cause undesired operation of the device.

FCC Caution: Any changes or modifications not expressly approved by the party responsible for compliance could void the user's authority to operate this equipment.



Installation Instructions

- Connect the two pieces of the yard stake together by screwing Lower Stake (C) into Upper Stake (B).
- Attach the assembled stake to the Connector Body (A) by screwing the top of Upper Stake (B) into the base of the Connector Body (A).
- Be sure to firmly tighten the assembled stake to the Connector Body (A) before installing into the ground.
- The connector body (A) shall be maintained at minimum of 6 inches above the ground.
- Plug the power cord into a GFCI receptacle. The power cord is a 6ft 14/3 SJTW cord.

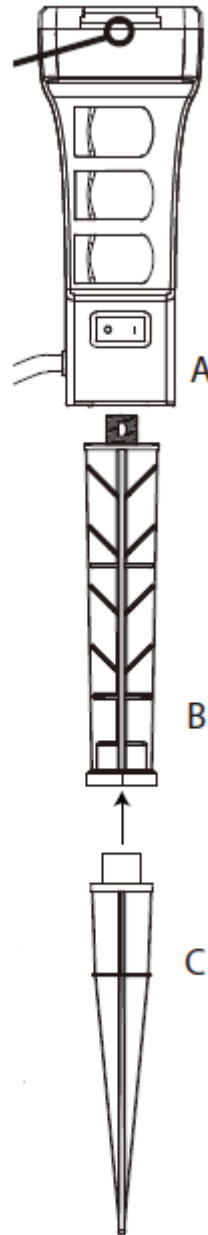



Operating Instructions

- The power stake can be operated via the included remote control from up to 100 feet or manually via the buttons on the connector body (receiver).

Remote Control Operation

- Press the ON or OFF button to turn the receiver power on or off respectively.
- Press the Timer button plus the 2Hr, 4Hr, 6Hr or 8Hr button to turn on the receiver for a specified time. After that specified time, the receiver will turn off. This setting will be repeated daily.
- Press the Sensor button (☀️) for dusk-to-dawn operation. This setting will turn on the receiver when sensing dusk and turn off the receiver at dawn.
- Press the Sensor button plus the 2Hr, 4Hr, 6Hr or 8Hr button to turn on the receiver for a specified time after sensing dusk. After that specified time, the receiver will turn off.

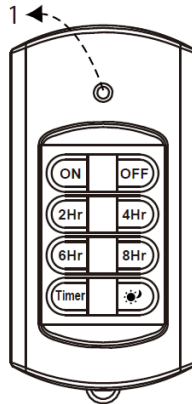

Remote Control Battery Information

- The RF (radio frequency) transmitter is powered by one 3V (CR2032) lithium battery (included with remote control).
- To replace the battery, remove the battery compartment cover away from the remote.
- Remove the old battery and place a new 3V (CR2032) lithium battery into the battery compartment.
- Install the new battery observing the positive (+) side up as indicated inside the battery compartment.
- Replace the battery compartment cover.
- Dispose or recycle spent/discharged batteries in compliance with all applicable laws. For detailed information, contact your local solid waste authority.

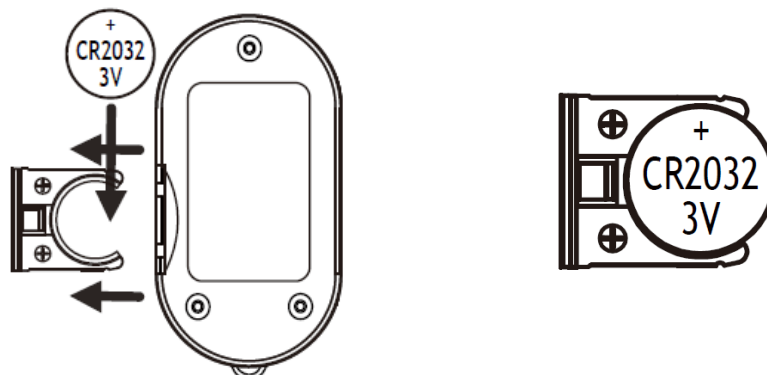



Manual Operation

- Press the timer control button (E) to turn on the receiver. The Power indicator (D) will be illuminated.
- Press the timer control button (E) until the Sensor indicator (D) is illuminated to activate the dusk-to-dawn setting. This setting will turn on the receiver when sensing dusk and turn off the receiver at dawn.
- Press the timer control button (E) until the Sensor indicator and the 2hr, 4hr, 6hr or 8hr indicator (D) are illuminated. This setting will turn on the receiver for a specified time after sensing dusk. After that specified time, the receiver will turn off.
- Press the timer control button (E) until the Timer indicator and the 2hr, 4hr, 6hr or 8hr indicator (D) are illuminated. The receiver will turn on immediately, then off after the specified time. This setting will repeat daily.

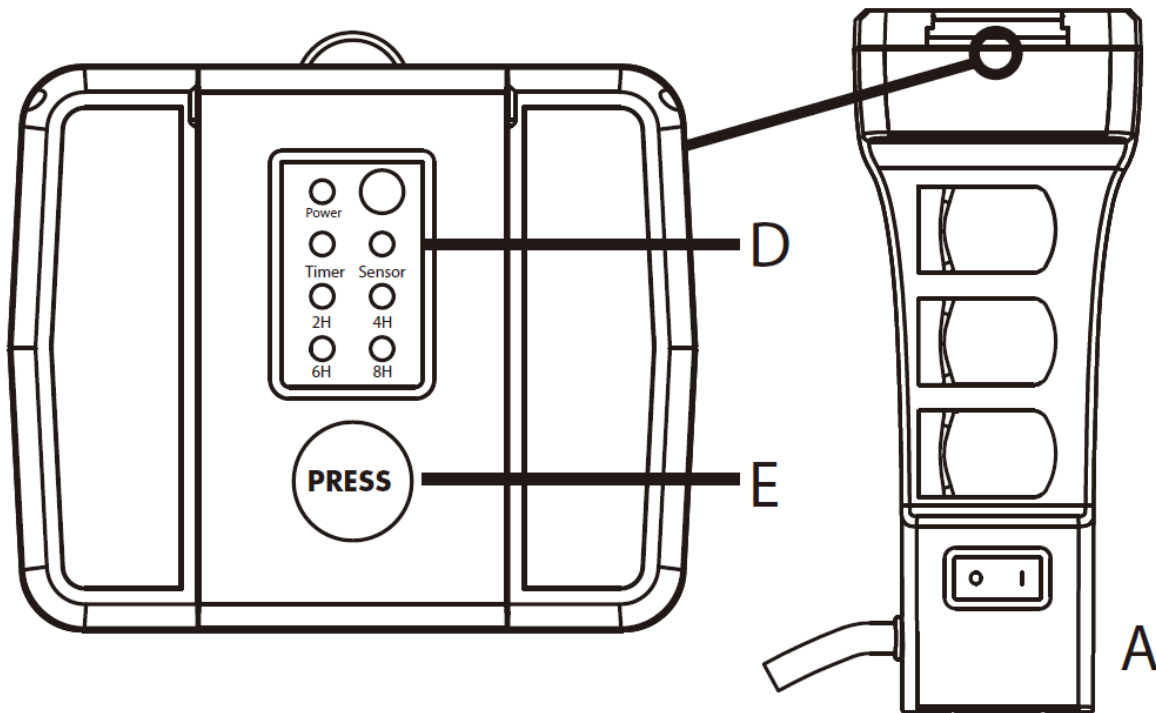

Operation Tips

- When set to ON, the receiver will provide continual power to all connected devices until the receiver is switched to OFF or switched to any of the other operating modes.
- In the sensor (☀) mode, temporary light sources like headlights, porch lights, streetlights and other external light sources will not interfere with the photocell function unless the external light source is on for more than 15 minutes. In that case, the receiver will shut off until darkness is restored. This function has been implemented to avoid flickering, or constant on/off for all connected devices.
- Once sensor (☀) mode activates at dusk in conjunction with the 2hr, 4hr, 6hr, or 8hr mode, the program cycle will complete before the timer resets. Headlights, porch lights, streetlights and other external light sources will not interfere with the active program.



Troubleshooting

- The receiver (connector body) doesn't turn on – Make sure the AC power cord is securely plugged into an AC receptacle. Unplug the unit for a moment, and then plug it back in again. Check the receptacle by plugging in another device.
- The remote control doesn't work – Make sure the battery is new. Make sure the transmitter and the receiver are set to the same channel. Stand closer to the receiver, the range should be up to 100 feet. Doors or walls will reduce the transmittance distance.
- In case of overloading, this product is equipped with a circuit breaker which will shut off all power. Eliminate the overload and then push to reset the circuit breaker for overload protection.