



QTL Series Quick Connect High Bay

Product Specifications



The QTL Series Quick Connect High Bay family features a lightweight extruded aluminum body, 4FT length, and up to 14,000 lumens resulting in a versatile solution for endless applications. TCP's Quick Connect system allows for fast, low-cost installation and produces a one-of-a-kind look in application. Adding one long, uniform run of High Bays in your warehouse can eliminate dark spots on products to help avoid "mispicks".

With the included mounting equipment, optional controls, battery backup options and Quick Connect system, the QTL Series HB by TCP is changing the game of high bay lighting. It is truly a new way to high bay.

Reasons to choose the LED Quick Connect High Bay from TCP

- Lightweight, quick install construction
- Uplight - no cave effect
- Standard frosted lens for glare control
- No shadows for smooth, even lighting
- Damp location rated
- 0-10V smooth dimming
- 250 or 400W HID equivalent
- 50,000 hour rated life
- Wide 120 degree beam spread
- Optional controls available
- Includes 6-foot Quick Connect power cord
- TCP SmartStuff compatible **COMING SOON!**

Ideal Applications

- High ceiling locations
- Commercial settings
- Industrial settings
- Retail settings
- Warehouses



QTL Series Quick Connect High Bay

A new way to high bay - Linear Strip Application using TCP Quick Connect



TCP Quick Connect System

Step 1:

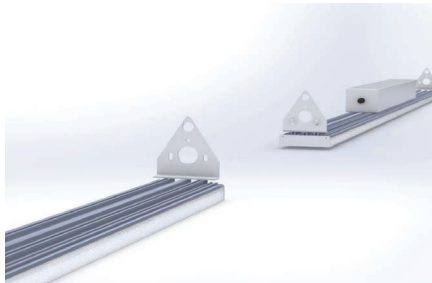

Align male and female ends of the Quick Connect triangles

Step 2:

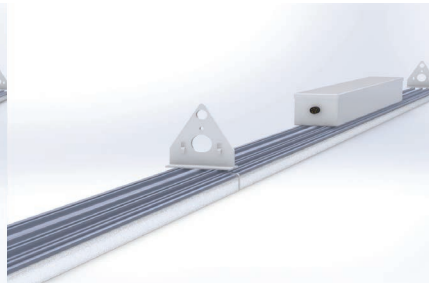

Slide together to fasten

Step 3:

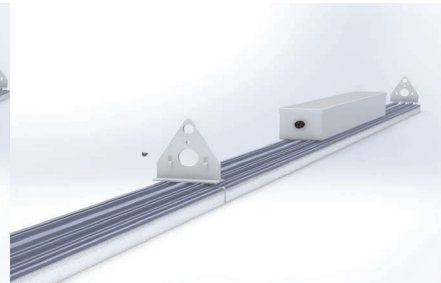

Fasten locking screw until tight

Step 4:

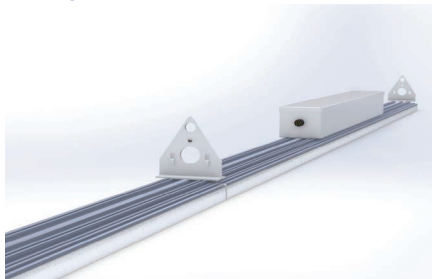

Mechanical connection complete

Step 5:



Use Q5DAISY4FT Quick Connect cable to daisy chain units together

NOTE:

Electrical Daisy Chain Capabilities using Q5DAISY4FT: 110W model = 8 units in series





QTL Series Quick Connect High Bay

Applications

The QTL Series Quick Connect High Bay is a versatile solution for endless creative applications. With a lightweight, extruded aluminum body, included mounting hardware, and Quick Connect system, the QTL Series HB by TCP is changing the game of high bay lighting. It is truly a new way to high bay. Best for use in high ceiling locations in commercial, industrial, retail, or warehouse settings.

Features

- Lightweight, quick-install construction
- Standard frosted lens for glare control
- No shadows for smooth, even lighting
- Damp location rated
- 0-10V smooth, no flicker dimming
- Operating temperature: -4° to 122°F
- Long 50,000 hour rated life
- Wide beam spread due to LED design providing a clean cutoff
- Optional battery backup or motion sensors available
- Includes 6-foot power cord

Hardware Included

- 10' adjustable aircraft cable hanger
- 6' Quick Connect cord

Installation

Before hanging installation, please consult your local ordinances and building codes

Catalog Ordering Matrix Example: QHB4UZDA250K

QHB	4	U	ZD	A2	50K	FACTORY INSTALLED OPTIONS	FACTORY INSTALLED CONTROLS ⁴
FAMILY	LENGTH	VOLTAGE ³	CONTROLS	LUMEN PACKAGE (Power) ²	CCT		
QHB - QTL Series High Bay	4 - 4 foot	U - 120-277V	ZD - 0-10V Dimming	A2 - 14,000L (110W)	40K - 40K CCT 50K - 50K CCT	Blank - No Add-on B - Battery Backup	Blank - No controls SMS - SmartStuff Microwave Motion Sensor COMING SOON!

¹ Approximate lumen output. Actual performance may vary based on CCT, options selected and end use application.

² Actual wattage may differ by +/- 10%

Field Installed Accessories

Q5DAISY4FT - 5-wire Quick Connect cable to connect multiple units end to end



Listings

cULus Listed
RoHS Compliant
DLC 5.1 Standard

Warranty

Five year limited warranty against defects in manufacturing.



Wireline Dimensions

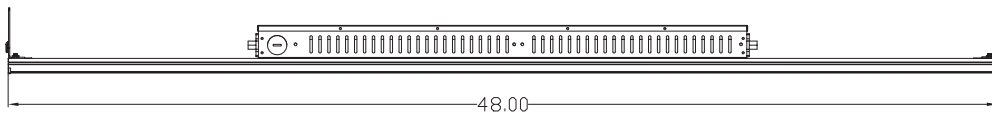

QHB4UZDA250K

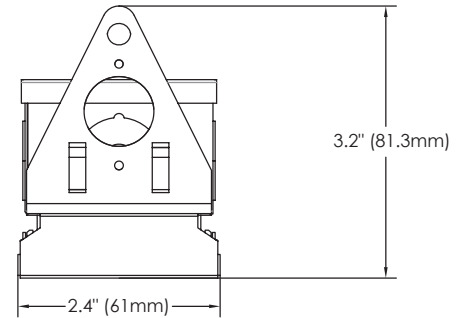

6FT Quick Connect Cord 2-Step Installation:



Take control of your lighting with the SMS sensor add-on

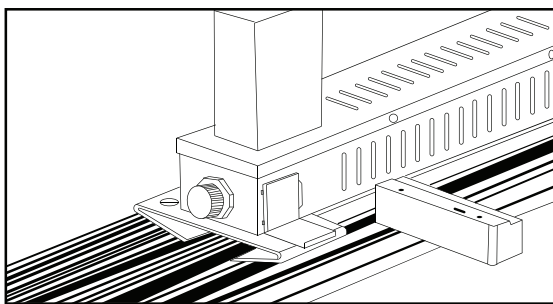

Order for SMS sensor add-on shown above. Toolless field placement of sensor on provided heavy-duty double-sided tape.

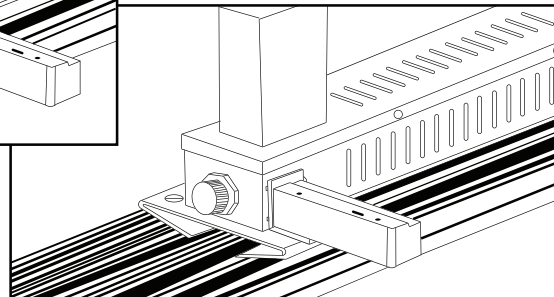

TECHNOLOGY CAST IN A BEAUTIFUL LIGHT

For over 20 years, TCP has been designing, developing and delivering energy-efficient lighting into the market. Thanks to our cutting-edge technology and manufacturing expertise, we have shipped billions of high quality lighting products. With TCP, you can count on a lighting product that is designed to meet the needs of the market - that transforms your surroundings and envelopes you in warmth - lighting that generates beauty with every flip of the switch.

Sales:

Date:

Model:

Project:

Rep:

Catalog Number:

Type:

Notes:



For more information on the quality and care TCP can deliver, call us at **800.324.1496** or visit tcp.com

325 Campus Dr. | Aurora, Ohio 44202 | P: 800.324.1496 | F: 877.487.0516