



Item#: **PLT-20259**
LED 2X4 RECESSED DIRECT/INDIRECT
LED READY FIXTURE

FEATURES

- Indirect lighting reduces shadows and glare
- Use 30% less energy than a linear fluorescent fixture.
- Swing down micro perforated lamp shield for easy re-lamping and for quick maintenance
- LED ready with non-shunted sockets
- Pre-wired for double-ended lamps
- Compatible with traditional ceiling grids

APPLICATION

Ideal for offices, retail, commercial buildings, classrooms, hospitals and work areas.

ELECTRICAL

Lamp Type (not included)	T8
Number of Lamps	2
Voltage	120-277V

ENVIRONMENT

Operating Temperature	-4° ~ 122°F
Suitable Location	DAMP
Ingress Protection Rating	IP40

LIFESPAN

Warranty (Years)	3
------------------	---

CONSTRUCTION

Housing	24 Gauge C.R.S.
Reflector	White Aluminum
Base / Power Supply	Hard Wired
Finish	High Gloss Baked White Enamel

QUALIFICATIONS



Operating temperature may vary depending on the lamps used. • Specifications are subject to change without notice.

Item#: **PLT-20259**
LED 2X4 RECESSED DIRECT/INDIRECT

DIMENSIONS (Inches)

Length	47.8"
Width	23.8"
Height	5.5"
Weight (Lbs)	--

SUPPORTING DOCUMENTS (Grey = not available at this time.)

Product Sheet	VIEW
Install Instructions	VIEW

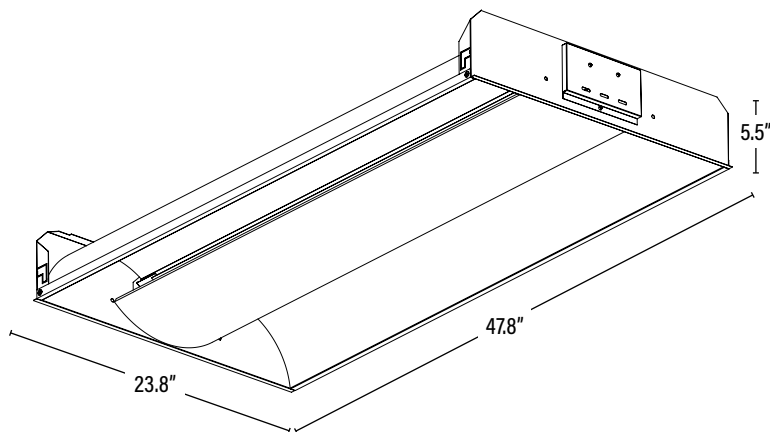

ITEM INFORMATION

PACKAGING

		UPC	DIMENSIONS (LxWxH)	GROSS WEIGHT (Lbs)
Master Carton	1	811768027297	49.9" x 24.3" x 5.8"	9.9
Country of Origin	China			
HS Tariff	9405.10.6020			

ORDERING

ITEM#	DESCRIPTION	CASE
55651	LED 2X4 RECESSED DIRECT/INDIRECT FOR 2 T8/DE - SUPERIOR LIFE®	1

REPLACEMENT PARTS

550428	REPLACEMENT LENS FOR 2X4 RECESSED DIRECT/INDIRECT	1
--------	---	---

ADDITIONAL INFORMATION:

- Pairs with Superior Life® Direct Wire Single-End or Double-End UL Type B Lamps. Follow specific lamp installation wiring instructions for correct wiring.