

Installation Instruction

⚠ WARNING

- To reduce the risk of death, personal injury or property damage from fire, electric shock, falling parts, cuts/abrasions, and other hazards read all warnings and instructions included with and on the fixture box and all fixture labels.
- Before installing, servicing, or performing routine maintenance upon this equipment, follow these general precautions.
- Commercial installation, service and maintenance of luminaires should be performed by a qualified licensed electrician.
- For the installation: If you are unsure about the installation or maintenance of the luminaires, consult a qualified licensed electrician and check your local electrical code.
- To prevent wiring damage or abrasion, do not expose wiring to edges of sheet metal or other sharp objects.
- Do not make or alter any open holes in an enclosure of wiring or electrical components during kit installation.

⚠ WARNING

- Turn off electrical power at fuse or circuit breaker box before wiring fixture to the power supply.
- Turn off the power when you perform any maintenance.
- Verify that supply voltage is correct by comparing it with the luminaire label information.
- All wiring connections should be capped with UL approved wire connectors.

⚠ CAUTION

- Avoid direct eye exposure to the light source while it is on.
- Account for small parts and destroy packing material, as these may be hazardous to children.
- Risk of burn. Disconnect power and allow fixture to cool before changing handling fixture.

NOTICE: Green ground screw provided in proper location. Do not relocate.

NOTICE: Minimum 90° supply conductors.

NOTICE: Specifications and dimensions subject to change without notice.

NOTICE: Suitable for wet location.

General Wiring Diagram

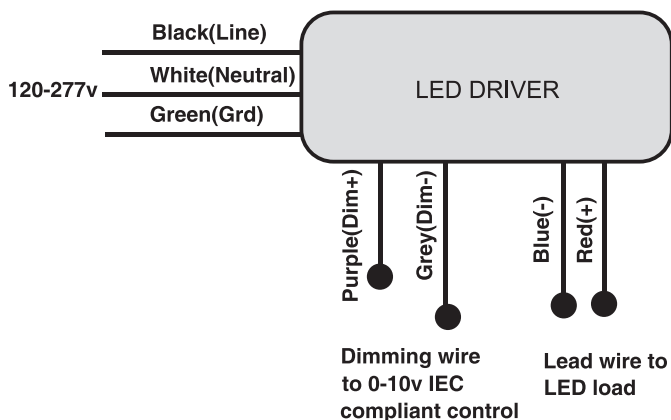

LED

Vapor Tight Fixture

PLT &

Installation Instruction

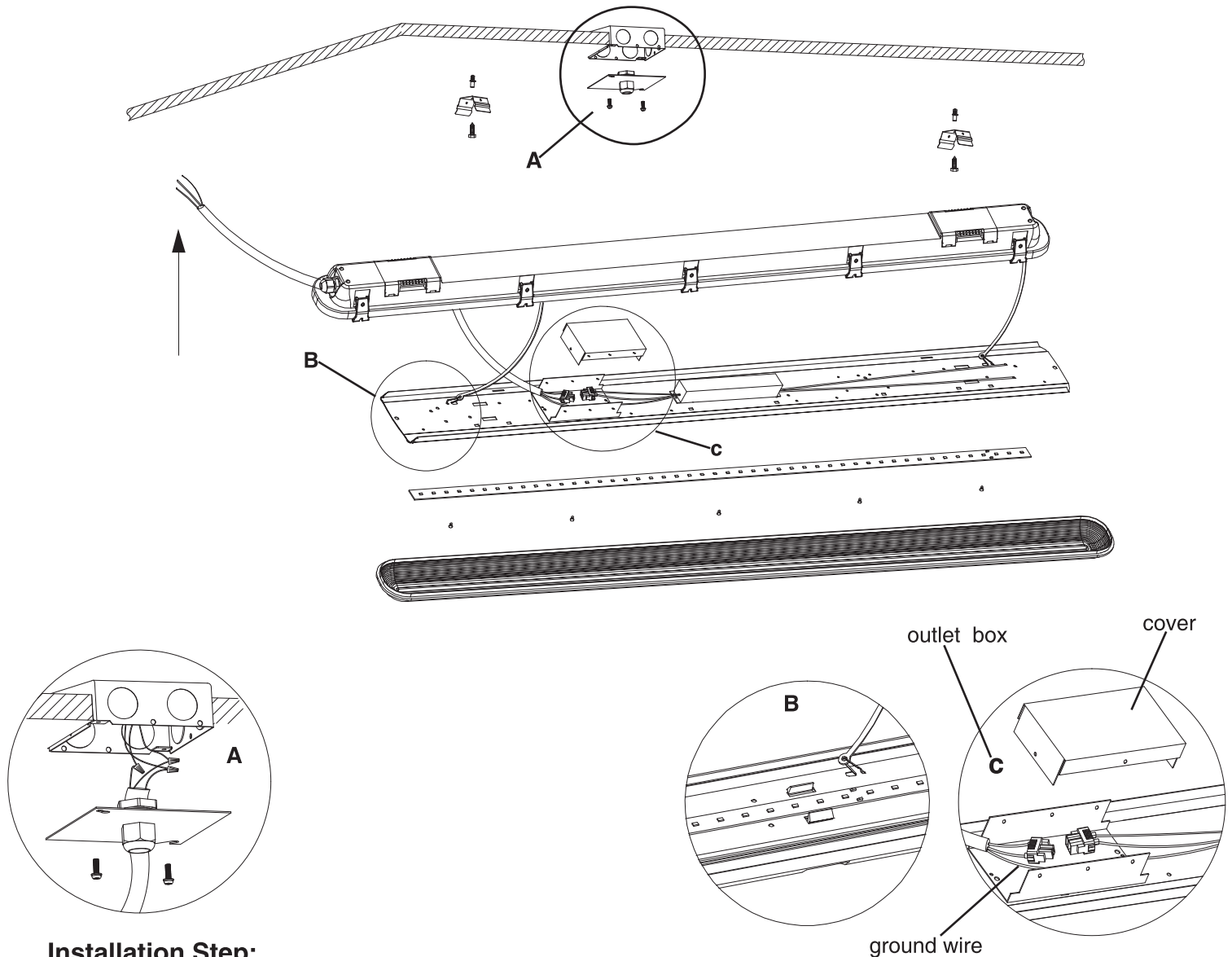

Installation Step:

Always turn off the power supply from main circuit breaker first!

1. Locate drill holes for mounting brackets. Use hardware found in hardware kit. Mount brackets to surface.
2. Unlatch and remove the lens from the fixture housing. Detach the LED tray from the fixture housing.
3. Assemble the PG13.5 waterproof cable connector, and position it in the appropriate end of the fixture housing.
4. Bring an (owner-supplied) 6-10 millimeter diameter electrical cable through the PG13.5 waterproof cable connection, and connect power to the driver through the outlet box as shown in Figure C. Snap the wiring box cover into place after electrical connections are made.
5. Reattach the LED tray into the fixture housing. Reattach and latch the lens to the fixture housing. Snap the fixture body into the previously installed surface mounting brackets.
6. Ensure that the power supply is disconnected before making electrical connections as presented in Figure A. Once connections are made and the junction box is properly covered, restore power.