

Features & Specifications



LED Strip Lights Selectable CCT & Wattage

INTENDED USE – LED strip light fixtures can be used for warehouses, indoor storage facilities and office buildings. These LED fixtures will yield a significant reduction in energy consumption compared to standard fluorescent fixtures and virtually eliminate ongoing maintenance expenses with a long-lasting lifespan. Designed for use in utility areas and stairwells, this LED strip light fixture will provide a brighter light output compared to fluorescent alternatives.

CONSTRUCTION – Heavy-duty die cast aluminum housing with white polyester powder paint for corrosion-free durability. Resistant to rough vibrations and external impacts. Heavy duty frosted lens protects the LEDs and provides even light distribution.

OPTICS – High-performance LEDs maintain a range of 2,340 to 3,960 Lumen output for 50,000 hours of use. Features Seoul Semiconductor LEDs.

ELECTRICAL – Input voltage of 120-277 VAC, 50/60Hz. Consider adding a surge protector to protect your fixtures from power surges in your electrical system as an added insurance policy to your investment.

INSTALLATION - Please consult installation instructions. Dimmable down to 10% using a 0-10V driver.

LISTINGS – UL Certified.

WARRANTY – 3-year warranty. PLT products that are damaged or defective will be repaired or replaced at PLT's choosing for a period of 3 years. Contact 1-800-624-4488 for more information.



Dimensions:

Length: 47.3 in.
Width: 3.4 in.
Height: 3.6 in.
Weight: 4.5 lbs.

Dimensions:

Length: 47.3 in.
Width: 3.4 in.
Height: 3.6 in.
Weight: 4.5 lbs.

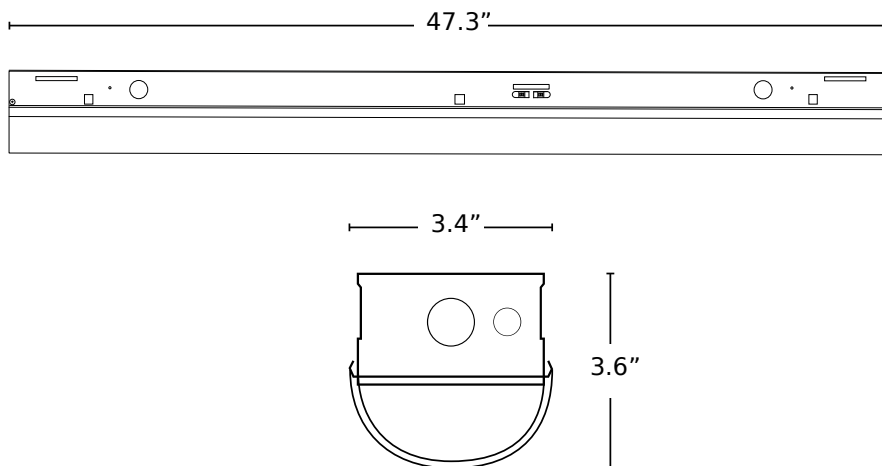

SKU #	Kelvin	Lumens	Wattage	Voltage	DLC	Mounting	Life Hours	Warranty
PLT-55610	3500/4100/5000	2340/3275/3960	18/25/30	120-277	No	Surface	50,000	3 Years