

ELI-S-250

SINEWAVE INVERTER

bodine

Installation and Operation Instructions

ELI SERIES EMERGENCY LIGHTING INVERTERS



! IMPORTANT SAFEGUARDS !

WHEN USING ELECTRICAL EQUIPMENT, BASIC SAFETY PRECAUTIONS SHOULD ALWAYS BE FOLLOWED, INCLUDING THE FOLLOWING:

READ AND FOLLOW ALL SAFETY INSTRUCTIONS

1. Do not use outdoors.
2. Do not let power supply cords touch hot surfaces.
3. This product is suitable for use in damp locations where the ambient temperature is 20°C minimum, 30°C maximum. Product is not suitable for heated air outlets and wet or hazardous locations. DO NOT INSTALL NEAR GAS OR ELECTRIC HEATERS.
4. Equipment should be mounted securely in locations and at heights where it will not be readily subjected to tampering by unauthorized personnel.
5. The use of accessory equipment and replacement parts not recommended by the manufacturer may cause an unsafe condition.
6. Do not use this equipment for other than its intended purpose.
7. The AC voltage rating of this equipment is 120 or 277 VAC. Do not connect equipment to any other voltage.

SAVE THESE INSTRUCTIONS



IMPORTANT: BEFORE CONNECTING THE AC INPUT WIRES YOU MUST DETERMINE HOW THE CONNECTED EMERGENCY LIGHTING FIXTURES ARE TO OPERATE; NORMALLY-ON ALL THE TIME, NORMALLY-OFF AND ONLY COME ON DURING A POWER FAILURE, OR SWITCHED ON/OFF. WIRE ACCORDING TO THE APPROPRIATE FOLLOWING SECTION. CONSULT FACTORY FOR SPECIAL WIRING DIAGRAMS. CONNECT GROUND WIRE IN ACCORDANCE WITH LOCAL CODES.

Before the installation takes place!! Be sure that ALL combined/connected Emergency lighting loads OVER 250W are capable of being dimmed down to a power output of 10% from an industry standard 0-10Vdc source.

ELI-S-250 WILL ONLY deliver 250W (or 280VA) into ANY load. This is accomplished by automatically dimming the connected Emergency lighting loads down to a total of 250W (280VA).



THIS PRODUCT INCLUDES RECHARGEABLE LEAD-ACID BATTERIES. THE BATTERIES MUST BE RECYCLED OR DISPOSED OF PROPERLY.

01/14/19

Bodine © 2018 Signify Holding. All rights reserved.

236 Mt. Pleasant Rd. • Collierville, TN USA 38017-2752 • Tech Support 888-263-4638 • Fax 901-853-5009 • www.bodine.com 81000083

STEP #1 **INSTALLING THE EMERGENCY LIGHTING SYSTEM**

- > Remove front cover and any packing material inside the unit housing that may have been used for shipping purposes.
- > Secure housing to the mounting surface through the keyhole knockouts using mounting hardware (not supplied). This hardware must be appropriate to hold the unit weight of approximately 80 lbs. with the batteries installed.
- > Remove the knockouts to install input and output wiring conduit fittings.
- > Extend AC supply wiring, output load wiring, and optional 0-10V dimming control wiring into the equipment enclosure using appropriate wiring hardware and methods.
- > Illustration 1 details the locations of the various wiring terminals needed for the remainder of the installation. Reference Illustration 1 for steps through 2 through 5.

ILLUSTRATION 1

ELI-S-250 INSTALLATION QUICK REFERENCE GUIDE

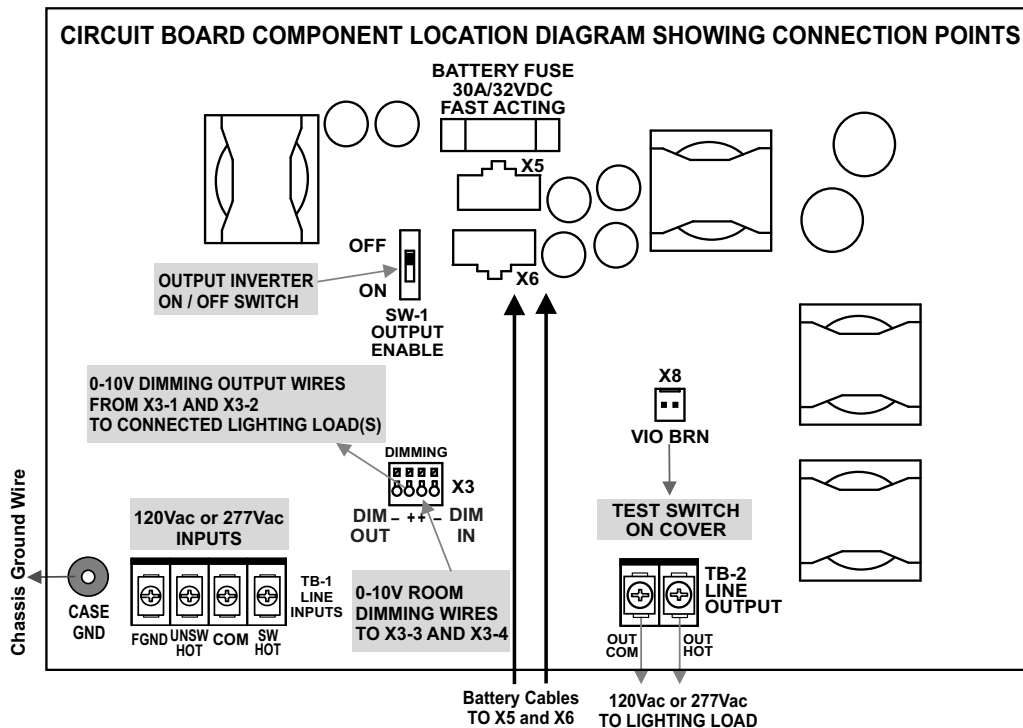

STEP #2 **WIRING THE EMERGENCY LIGHTING INVERTER'S PRIMARY POWER CONNECTIONS**

NOTE: Make sure all connections are in accordance with the National Electrical Code, Canadian Electrical Code and any local regulations.

Reference Illustration 1 when making the following wiring connections.

- > Connect the Load Common lead to screw terminal TB-2 "OUT COM"
- > Connect the Load Hot lead to screw terminal TB-2 "OUT HOT"
- > Connect the Emergency Lighting Inverter to ground using screw terminal TB-1 "FGND"
- > Connect the AC Power Source Common to screw terminal TB-1 "COM"
- > Connect the Unswitched Hot input to screw terminal TB-1 "UNSW HOT"
- > Connect the Wall switch hot wire to screw terminal TB-1 "SW HOT". This is the means of powering the load luminaires in Normal Mode when a wall switch is used to turn these luminaires on and off. If no wall switch is used, and the load luminaires are controlled by the same circuit breaker that is powering the unswitched hot. In this case TB-1 "SW HOT" must be jumpered to TB-1 "UNSW HOT".



CAUTION:

- Ensure input and output primary wiring connections are made to the proper terminals. Damage to product may occur if miss wired.
- Ensure load voltage requirements match the output ratings of this product or damage to the load devices may occur.

STEP #3 WIRING THE EMERGENCY LIGHTING INVERTER'S DIMMING CONNECTIONS (OPTIONAL)

The ELI-S-250 features an industry-standard 0-10 VDC dimming voltage output. Existing area dimming controls can be wired through the ELI-S-250 dimming relay to allow for normal dimming by occupants of the area during Normal mode operation. The X3 connector accepts wire size # 24 AWG to # 16 AWG. Refer to Illustration 1.

STEP #4 BATTERY CABLE CONNECTION

This product is provided with two sealed lead-acid batteries, which must be connected using the provided battery connection wires. You must connect the Battery cables using the supplied hardware, before installing the batteries into the cabinet. Insert the bolt into the lock-washer first, then through the ring terminal, then through the large metal cover-washer and finally into the threaded hole in the battery terminal (observing proper polarity by matching the cable color to the battery terminal color). Tighten to no more than 4 Ft/Lbs. torque. Refer to Illustration 4a for installation.

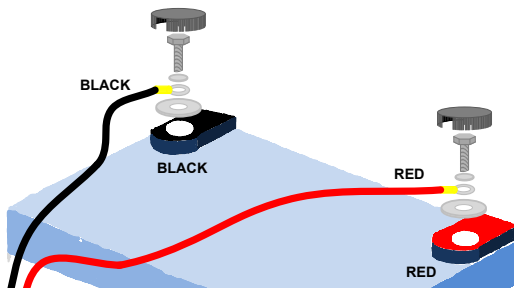

Illustration 4A

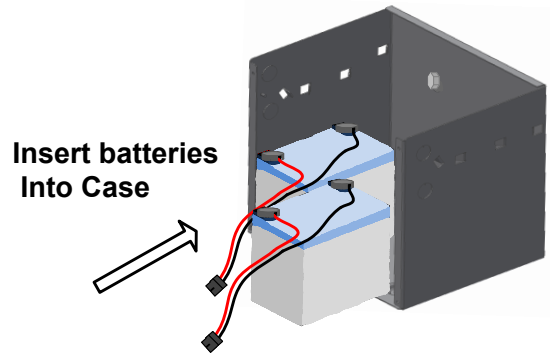

Illustration 4B

STEP #5 BATTERY INSTALLATION

Install the batteries as shown. With the unit secured to the mounting surface, slide the batteries into the enclosure as shown in Illustration 4B.



CAUTION: DO NOT CONNECT the battery cables to Circuit Board connectors X5 and X6 until the unit is ready for use. The batteries WILL BE discharged after long periods of unit inactivity while connected to the circuit board. If this occurs, the batteries will require at least 24 hours to recover before they can be used for emergency service.

STEP #6 ENABLE THE INVERTER AND APPLY AC POWER

- > After installation is complete, **and after the building power commissioning has been completed**, apply AC mains power and then turn on SW-1 on the ELI-S-250 Circuit board.

NOTE: The ELI-S-250 features a "power commission lockout" that prevents the inverter from operating in the Emergency Mode unless charging power (UNSW HOT) has been applied AFTER the batteries are connected.

- > At this point, the Charging Indicator Light on the test switch should illuminate indicating the battery is charging.
- > A short-term discharge test may be conducted after the Emergency Lighting Inverter has been charging for 12 hours. Charge for 24 hours before conducting a long-term discharge test. Refer to OPERATION.

STEP #7 INSTALLATION OF ENCLOSURE LID

- > Remove clip-nuts (X4) from accessory kit.
- > Press on to chassis flanges, over lid mounting holes.
- > Place lid onto unit chassis.
- > Install 8-32 screws in lid, through clip nuts(x4).

Clip-Nut Location

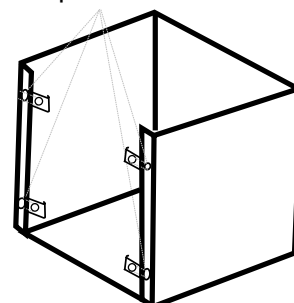

OPERATION

Normal Operation: AC power is supplied to the AC ballast/AC LED drivers within the connected Luminaires through the SW HOT input. The batteries are charged from power supplied to the UNSW HOT input. Turning on SW-1 on the circuit board supplies power to the control/monitor circuit and enables the Emergency Lighting Inverter. Dimming control, if used, are passed through the unit to the connected loads.

Emergency Mode Operation: Immediately after an AC power failure the ELI-S-250 applies back-up power to the connected loads and outputs a minimum dc voltage on the 0 – 10Vdc dimming supply. This causes the dimmable connected loads to start out at minimum light output and consequently, minimum power draw. The ELI-S-250 rapidly increases the 0 – 10Vdc dimming voltage until the output power draw reaches 250W into the connected load(s). This is referred to as “Auto-Dimming.” When AC power is restored, the ELI-S-250 returns to charging mode. The unit can also detect an abnormal load condition (shorted load) during emergency mode operation and will protect the inverter from damage.

Maintenance

Caution: Always turn off AC power to the equipment and turn off SW-1 inside the case before servicing. Servicing should be performed only by qualified service technicians. Use only manufacturer supplied replacement parts. Although no routine maintenance is required to keep the Emergency Lighting Inverter functional, it should be checked periodically to ensure that it is working.

Testing

The following schedule is recommended

1. Visually inspect the charging indicator light monthly. It should be illuminated.
2. Test the emergency operation at 30-day intervals for a minimum of 30 seconds by pushing the illuminated test switch located on the front of the unit.
3. Conduct a 90-minute discharge test once a year. This can be accomplished by turning off the circuit breaker associated with the AC line inputs to this equipment.

Battery: The Batteries supplied with this equipment requires no maintenance. However, it should be tested periodically and replaced whenever it will no longer operate the connected fixtures for the duration of a 90-minute test. The batteries supplied have a life expectancy of 4 years when used in normal ambient temperature of 72 degrees F.

Fuse: The fuse contained within this product is field replaceable. For the battery fuse location see illustration 1. To replace the fuse, remove AC Power from the product and turn off SW-1. Ensure that the battery fuse F101 is replaced by Littelfuse 0312030 (312-030) or equivalent 3AG, 30 A, 32 VDC.

Troubleshooting

Emergency lights do not operate

- If charge indicator is off: Check if the circuit breaker for AC supply is on.
- If charge indicator is on and blinking: Check that the batteries are properly connected. This can also indicate a failed battery.

! REFER ANY SERVICING TO QUALIFIED PERSONNEL !

Output Ratings and Replacement Parts

Model Number	Voltage	Output Ratings	Electronics Module *	Replacement Batteries	
			Part No.	Part No.	Quantity
ELI-S-250	120/277Vac	250W / 280VA	PRT00142	PRT00141	2 Required
			* Heatsink + Pc Board		

NOTE: ELI-S-250 requires 2 batteries. batteries should be replaced in pairs. Replacement PRT00141 will be sold individually.

NOTE: The Power-Sonic battery date code is made up of 5 characters which represent the month, day and year of manufacture (MM/DD/Y). For example, 08023 means the battery was made August 2, 2013. There may be additional alpha-numeric characters at the end of the date code. The date code is located on the battery carton and additionally engraved into the battery.

WIRING DIAGRAM

DIMMABLE EMERGENCY LIGHTING SYSTEM

ANY QUANTITY

TOTAL DIMMABLE POWER
UP TO 800W

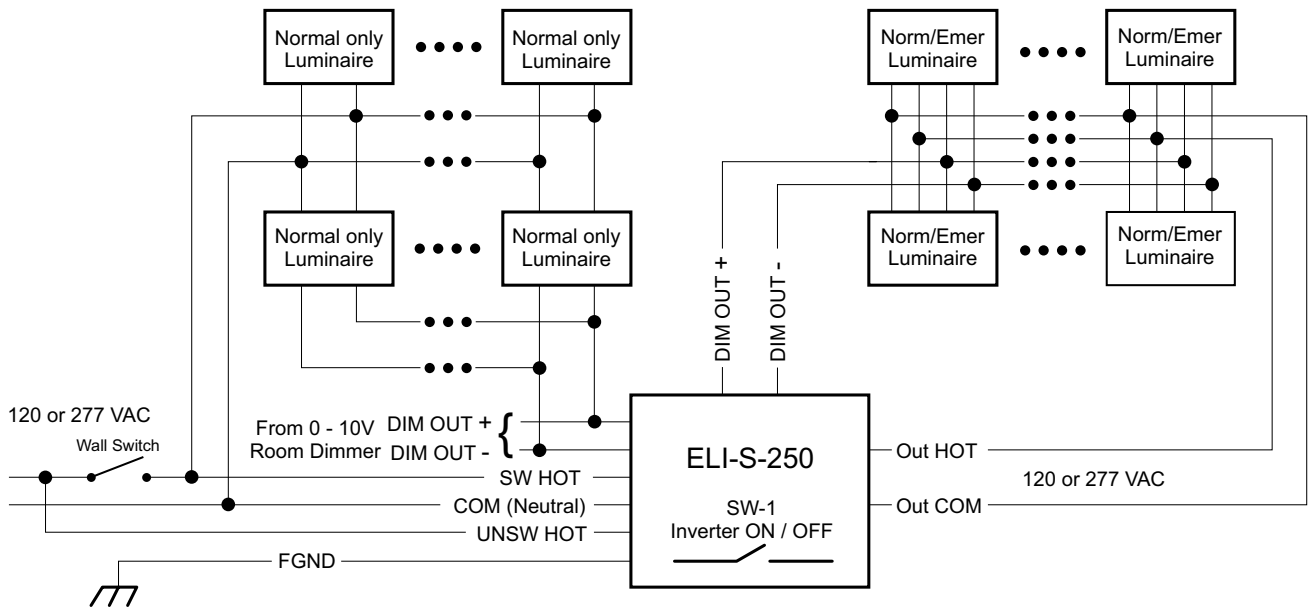

FIGURE W1

Figure W1, above shows an example of a branch circuit powering a number of dimmable luminaires, 4 (or more) of which are powered through an Emergency Lighting Inverter. During normal AC power mode, the power from the switched hot Lighting power and 0-10V room-dimmer voltage is passed through The ELI to the “Normal/Emergency” fixtures. The **unswitched** hot charges the battery. During a power failure, the Emergency Lighting Inverter powers the “Normal/Emergency” fixtures for a minimum of 90 minutes, at a power level set by the Emergency Lighting Inverter’s dimming output circuit. In any example, the **dimmable** “Normal/Emergency” luminaires are automatically limited to **only** draw a total maximum of 250W Watts from the ELI-S-250 during an emergency event.

Figure W2, below shows an example of an alternate Emergency Lighting system in which the Emergency Luminaires ARE NOT dimmable. In this case, the total connected Emergency lighting load MUST BE LESS THAN or EQUAL to 250W.

Non-DIMMABLE EMERGENCY LIGHTING SYSTEM

ANY QUANTITY

TOTAL POWER
= 250W

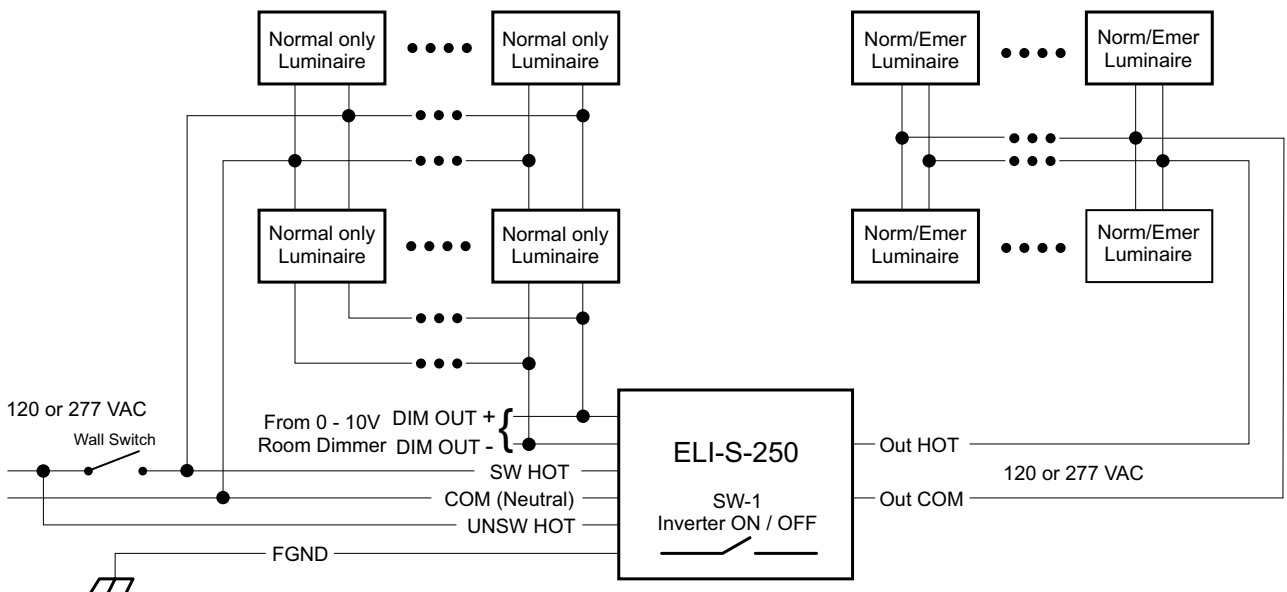

FIGURE W2