

# ELI-S-100

WITH AUTO-DIMMING FEATURE

# bodine

## Installation and Operation Instructions

ELI SERIES EMERGENCY LIGHTING INVERTERS



### **! IMPORTANT SAFEGUARDS !**

**WHEN USING ELECTRICAL EQUIPMENT, BASIC SAFETY PRECAUTIONS SHOULD ALWAYS BE FOLLOWED, INCLUDING THE FOLLOWING:**

## **READ AND FOLLOW ALL SAFETY INSTRUCTIONS**

- 1. Caution:**
  - High voltage will be present on the output wires and terminals if batteries are installed and inverter connector is joined or if AC power is supplied to the switched and unswitched terminal.
  - Ensure input and output primary wiring connections are made to the proper terminals. Damage to product may occur if miswired.
  - Ensure load voltage requirements (120 or 277 Vac) match the output ratings of this product or damage to the load devices may occur.
- 2.** This product is suitable for use in dry and damp locations where the ambient temperature is 0°C through 40°C, depending on load. See output ratings on product label for details. This product is not suitable for heated air outlets and wet or hazardous locations.
- 3.** Make sure all connections are in accordance with the National Electrical Code or Canadian Electrical Code and any local regulations.
- 4.** To reduce the risk of electric shock, disconnect both the normal and emergency power supplies and the inverter connector of the emergency lighting inverter before servicing.
- 5.** Do not install near gas or electric heaters.
- 6.** An unswitched AC power source is required. The AC voltage rating of this equipment is specified on the product label. Do not connect equipment to any other voltage.
- 7.** Equipment should be mounted securely in locations and at heights where it will not be readily subjected to tampering by unauthorized personnel.
- 8.** The use of accessory equipment and replacement parts not recommended by the manufacturer may cause an unsafe condition.
- 9.** Do not use this equipment for other than its intended purposes.
- 10.** The battery is field replaceable. Contact manufacturer for information on replacement. Use caution when replacing battery. Dispose of the battery properly. Do not incinerate.

### **SAVE THESE INSTRUCTIONS**



**THIS PRODUCT INCLUDES RECHARGEABLE LEAD-ACID BATTERIES.  
THE BATTERIES MUST BE RECYCLED OR DISPOSED OF PROPERLY.**

11/27/18

Bodine © 2018 Signify Holding. All rights reserved.

236 Mt. Pleasant Rd. • Collierville, TN USA 38017-2752 • Tech Support 888-263-4638 • Fax 901-853-5009 • www.bodine.com  
81000092

# INSTALLATION



**WARNING: TO PREVENT HIGH VOLTAGE FROM BEING PRESENT ON THE AC OUTPUT LEADS (HOT AND NEUTRAL) PRIOR TO INSTALLATION, INVERTER CONNECTOR MUST BE OPEN. JOIN INVERTER CONNECTOR INSIDE THE CASE AFTER INSTALLATION IS COMPLETE AND AC POWER IS SUPPLIED.**

**NOTE:** Make sure the inverter connector is closed before screwing the front cover to the case.

## STEP #1 INSTALLING THE EMERGENCY LIGHTING INVERTER

- > Remove front cover and any packing material inside the unit housing that may have been used for shipping purposes.
- > Secure housing to the mounting surface through the keyhole knockouts using mounting hardware (not supplied). This hardware must be appropriate to hold the unit weight of 25 lbs with the batteries installed.
- > Remove the knockouts to install input and output wiring conduit fittings.
- > Extend AC supply, output load wiring, and optional control wiring into the equipment enclosure using appropriate wiring hardware and methods. Use copper wire only.
- > Illustration 1 details the locations of the various wiring terminals and switch locations needed for the remainder of the installation. Reference Illustration 1 for Steps through 2 through 6.

**ILLUSTRATION 1  
INSTALLATION QUICK REFERENCE GUIDE**

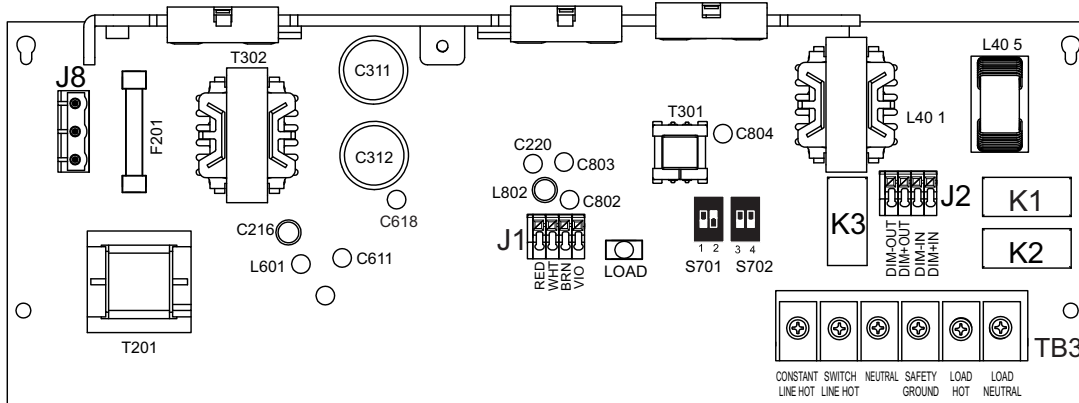

## STEP #2 WIRING THE EMERGENCY LIGHTING INVERTER'S PRIMARY POWER CONNECTIONS

**NOTE:** Make sure all connections are in accordance with the National Electrical Code, Canadian Electrical Code and any local regulations.

Reference Illustration 2 when making the following wiring connections.

- > Connect the Load Common lead to screw terminal TB3 -"LOAD NEUTRAL"
- > Connect the Load Hot lead to screw terminal TB3 -"LOAD Hot"
- > Connect the Emergency Lighting Inverter to ground using screw terminal TB3 -"SAFETY GROUND"
- > Connect the AC Power Source Common to screw terminal TB3 -"NEUTRAL"
- > Connect the Unswitched Hot to screw terminal TB3 -"CONSTANT LINE HOT"

Screw terminal "TB3 -SWITCH LINE HOT" is the means of powering the load luminaires in normal mode. If a wall switch is the local control means, this switched hot must be connected in order to power the load when AC power is present. If no wall switch is used, and the load luminaires are controlled by the same circuit breaker that is powering the unswitched hot, "TB3 -SWITCH LINE HOT" can be jumpered to "TB3 -CONSTANT LINE HOT".

# INSTALLATION

**ILLUSTRATION 2  
PRIMARY WIRING CONNECTIONS**

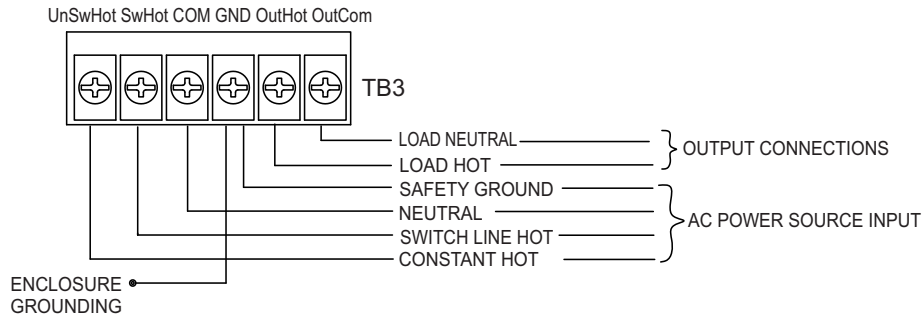

**CAUTION:**

- Unswitched and switched AC power must be fed from the same branch circuit.
- Ensure input and output primary wiring connections are made to the proper terminals. Damage to product may occur if wired incorrectly.
- Ensure load voltage requirements match the output ratings of this product or damage to the load devices may occur.

**STEP #3 BATTERY INSTALLATION**

This product is provided with two lead-acid batteries, which must be mechanically secured inside the enclosure using the battery bracket provided. They must then be wired using the battery connection wires also provided. Refer to Illustrations 3 and 4 for installation.



**CAUTION:**

- The battery date code is made up of five (5) characters which represent the month, day and year of manufacture (MM/DD/Y). For example, 080218 means the battery was made August 2, 2018. There may be additional alpha-numeric characters at the end of the date code. The date code or recharge date is located on the battery carton.
- DO NOT CONNECT the battery cable connector to the circuit board connector J8 until the unit is ready for use as the batteries may be discharged after long periods of unit inactivity (no AC power for charging).

Install the batteries as shown. With the unit secured to the mounting surface, place the batteries into the enclosure as shown in Illustration 3. Insert the battery bracket on the battery bracket stud, ensuring the bracket is placed against the batteries. Slide the ring terminal of the grounding wire over the battery bracket stud. Securely fasten the grounding wire and battery bracket against the batteries using the external toothed washer and nut. Once the batteries are secure, attach the battery harnesses as shown in Illustration 4.

**ILLUSTRATION 3  
BATTERY MECHANICAL INSTALLATION**

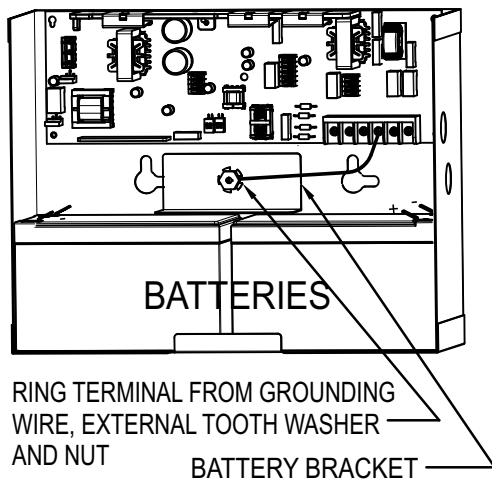

**ILLUSTRATION 4  
BATTERY WIRING CONNECTIONS**

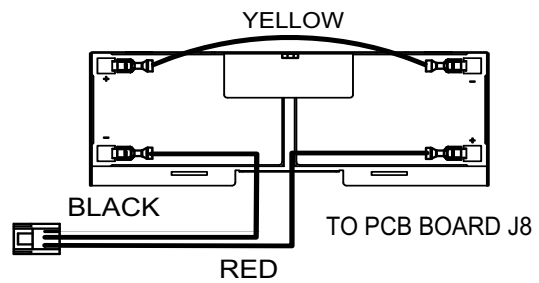

Attach the battery wires as shown in the illustration.

# INSTALLATION

## BATTERY REPLACEMENT

To replace the batteries, disconnect both switched and unswitched AC power to the emergency lighting inverter. Remove the two screws securing the lid to the enclosure base and remove the lid. Open the inverter connector wires and then unplug and remove the old batteries. Reverse this process to install the new batteries. Remember to join the inverter connector prior to reinstalling the lid. The charging indicator light should be illuminated once unswitched AC power is restored. Use only Bodine part number PRT00133 as replacement batteries. Utilisez uniquement la référence Bodine PRT00133 en tant que remplacement de la batterie.

## STEP #4 ► WIRING THE EMERGENCY LIGHTING INVERTER'S DIMMING CONNECTIONS (OPTIONAL)

The ELI-S-100 features an industry-standard 0-10 VDC dimming voltage output which allows emergency operation of one or more luminaires that consume a total of more than 100 VA when operating in the normal mode, (operating from the AC mains). These luminaires must have AC drivers (or ballasts) that are compatible with industry standard 0-10 VDC dimming operation. Existing area dimming controls can be wired through the ELI-S-100 dimming relay to allow for normal dimming by occupants of the area during normal mode operation. Refer to Illustration 5 on next page to wire the dimming output voltage to the load and the input connections from a dimming control device, if used. See Illustration 1 for the location of the dimming connector J2 on the product. The emergency mode dimming voltage can be automatically controlled by this inverter or can be manually selected by the switch settings of S701 and S702, which are located at the lower center section of the circuit board (see Illustration 1). See Step 5 for these settings.

**NOTICE!** Regardless of the inverter dimming method, the power consumed by the connected AC ballasts/LED drivers during start-up can be significantly higher than their steady state power consumption. When power from any source is applied to the AC ballasts/LED drivers, the input circuits consume a large amount of power for a few hundred milliseconds. This short duration power consumption is not the same as inrush current and is typically not mentioned in their specifications. It will vary, dependent on the individual AC ballast/LED driver manufacturer. Therefore, the actual number of dimmable AC ballasts/LED drivers that can be connected to an inverter must be predetermined by testing.

**ILLUSTRATION 5  
DIMMING CONNECTIONS**

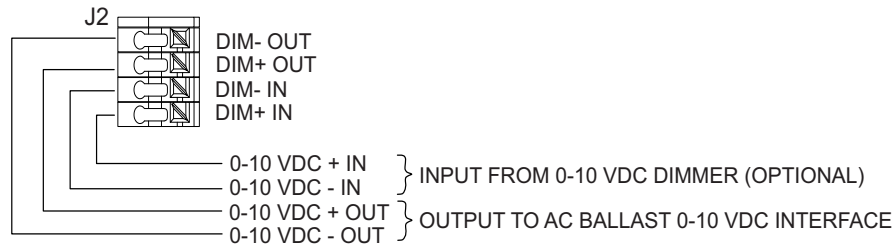

## STEP #5 ► SETTING THE OUTPUT DIMMING LEVEL (OPTIONAL)

Upon the loss of normal AC power, the emergency lighting inverter's internal 0-10Vdc dimming circuit will output a dimming voltage to the connected luminaires. The ELI-S-100 features automatic dimming level adjustment (AUTO-DIM) that will sense and maintain the AC Power output at 100 VA into the connected luminaires. The AUTO-DIM circuit begins at each loss of AC mains power with the dimming output set to 1 Vdc (approximately 10% light level). For up to 10 seconds, the dimming voltage gradually increases until the unit senses 100 VA to the load. The dimming voltage level is then maintained at that level until AC mains power is restored. The installer may also set the dimming voltage (light level) manually. Switches S701, S702 on the ELI-S-100 circuit board are used to manually set the dimming voltage that will determine the light level during emergency operation. Refer to Illustration 1 on page 2 for the switch locations and Illustration 6 for switch position settings. The unit must be in the emergency mode to activate this function. If the selected light level exceeds 100VA, an LED "LOAD" indicator located on the circuit board, next to the switches, will flash indicating that the ELI-S-100 has exceeded 100 VA output. The AUTO-DIM circuitry will gradually decrease the dimming voltage level until the power decreases to 100 VA.

**ILLUSTRATION 6  
DIMMING LEVEL SWITCH SETTINGS**

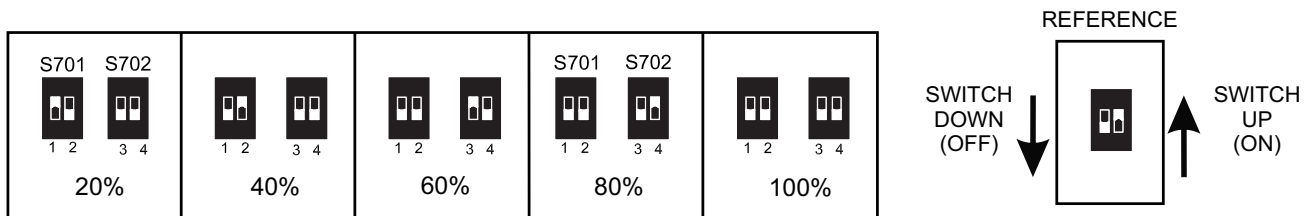

# INSTALLATION

## STEP #6 JOIN THE INVERTER CONNECTOR & APPLY POWER

- > After installation is complete, apply AC power and join the inverter connector inside the case then screw the front cover to the case.
- > **Note:** The inverter has a safety lockout feature that prevents AC output in emergency mode until AC mains power is connected and then lost.
- > At this point, power should be connected to both the AC ballast and the ELI-S-100, and the charging indicator light on the test switch should illuminate indicating the battery is charging.
- > A short-term discharge test may be conducted after the emergency lighting inverter has been charging for 1 hour. Charge for 24 hours before conducting a long-term discharge test. Refer to OPERATION.

## TROUBLESHOOTING GUIDE

CONDITION	ACTION
Flashing Indicator Light	Low or disconnected battery; check battery voltage (12VDC nominal) and connections. Replace battery if necessary.
Inverter Output Cycles	Overload; reduce load by disconnecting luminaires until cycling stops.

**NOTICE!** Regardless of the inverter dimming method, the power consumed by the connected AC ballasts/LED drivers during start-up can be significantly higher than their steady state power consumption. When power from any source is applied to the AC ballasts/LED drivers, the input circuits consume a large amount of power for a few hundred milliseconds. This short duration power consumption is not the same as inrush current and is typically not mentioned in their specifications. It will vary, dependent on the individual AC ballast/LED driver manufacturer. Therefore, the actual number of dimmable AC ballasts/LED drivers that can be connected to an inverter must be predetermined by testing.

## Operation

During normal operation, AC power is supplied to the AC ballast/driver through the ELI-S-100 and the batteries charge. Connecting the inverter connector wires (red and white) enables the emergency circuit and supplies power to the control monitor circuit. When AC power fails, the ELI-S-100 automatically switches to emergency mode, keeping the load illuminated for a minimum of 90 minutes. When AC power is restored, the ELI-S-100 returns to charging mode. The unit can also detect an abnormal load condition (open or shorted load) during emergency mode operation and will protect the inverter from damage.

## Maintenance



### CAUTION:

Service should be performed only by qualified service technicians. Always turn off AC power to the equipment, open the inverter connector and battery disconnect inside the case before servicing. Use only manufacturer supplied replacement parts.

Although no routine maintenance is required to keep the emergency Lighting Inverter functional, it should be checked periodically to ensure that it is working.

**Testing:** The following schedule is recommended

1. Visually inspect the charging indicator light monthly. It should be illuminated.
2. Test the emergency operation at 30-day intervals for a minimum of 30 seconds by pushing the illuminated test switch indicator light located on top of the unit.
3. Conduct a 90-minute discharge test once a year.

# INSTALLATION

**Battery:** The battery supplied with this equipment requires no maintenance. However, it should be tested periodically and replaced whenever it will no longer operate the connected fixtures for the duration of a 90-minute test. The battery supplied has a life expectancy of four (4) years when used in normal ambient temperature of 72°F.

**Fuse:** The fuse contained within this product is field replaceable. For fuse location see Illustration 1. To replace fuse, remove AC Power from the product and disconnect the inverter connector. Ensure fuse F201 is replaced with Littelfuse 0314015.MXP or equivalent 15 A, 125 VDC fast-blow, cartridge fuse.

**! REFER ANY SERVICING TO QUALIFIED PERSONNEL !**

## TYPICAL SYSTEM WIRING DIAGRAM

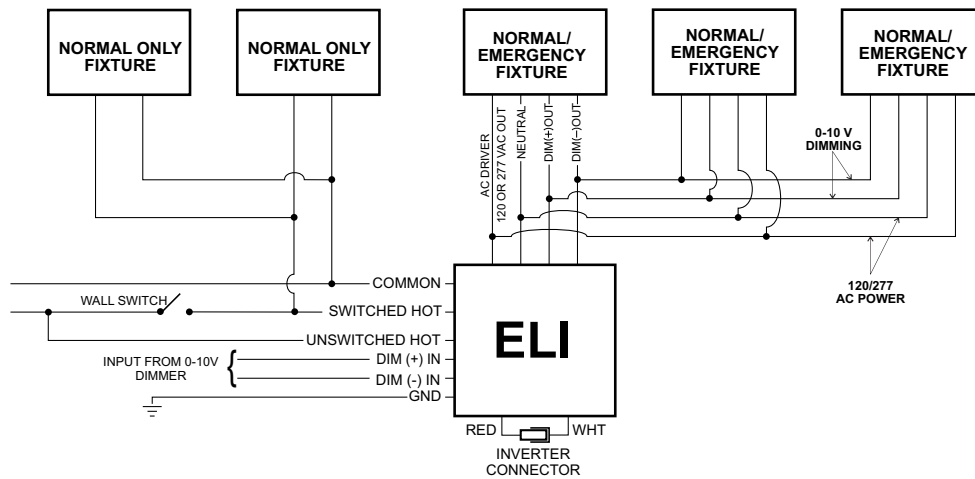

Diagram above shows an example of a branch circuit containing five (5) luminaires, three (3) of which are powered through an Emergency Lighting Inverter. During normal AC run mode, the power from the switched hot and dimmer voltage is passed through to the three “emergency” fixtures. The unswitched hot charges the battery. During a power failure, the Emergency Lighting Inverter powers the “emergency” fixtures for a minimum of 90 minutes, at a power level set by the Emergency Lighting Inverter’s dimming output level. In this example, each luminaire can draw a maximum of 33 VA, to total no more than 100 VA.

**Note:** Mark each designated emergency fixture with provided warning labels, 10 provided.