

## Auxiliary Power

Control Device

GTDU



Project: \_\_\_\_\_  
Location: \_\_\_\_\_  
Cat.No: \_\_\_\_\_  
Type: \_\_\_\_\_  
Lamps: \_\_\_\_\_ Qty: \_\_\_\_\_  
Notes: \_\_\_\_\_

### Upgraded Generator Transfer Device for generator or central inverter supplied lighting

Product order number: GTDUM  
12 NC number: 913702479201

#### Specifications

##### UL Listed

UL 924 and UL 1008 Listed for use as a Switch Bypass or Branch Circuit Emergency Lighting Transfer Switch (BCELTs) factory or field installation

##### Full Warranty

5 Years (NOT pro-rata)

##### Universal Input Voltage

120 through 277 VAC, 50/60 Hz

##### AC Input Current

30 mA

##### AC Input Power Rating

2.3 Watts

##### Switched Load Rating

Up to 277VAC at a maximum load current of 2 amps

##### Temperature Rating (Ambient)

-20°C to +65°C (-4°F to 149°F)

##### Dimensions

6.61" x 2.32" x 1.50" (168 x 59 x 38 mm)  
Mounting Center 5.98" (152 mm)

##### Weight

1.00 lbs. (0.45 kg)

#### Key Upgraded Features:

- Dual listed to UL 1008 (transfer switch) and UL 924 (switch bypass)
- 0-10V dimming control override capable
- Reduced AC line current and power consumption
- Universal input 120-277 VAC, 50/60 Hz
- 24VDC fire alarm override capable

#### Benefits:

- Allows ON/OFF switching of generator or central inverter supplied emergency lighting
- Can be used with incandescent, fluorescent or LED lighting loads and provide full light output when in normal mode
- Suitable for indoor or damp locations and plenum rated luminaires/enclosures
- 2A electronic ballast/driver rating
- No batteries required
- Meets or exceeds Life Safety Code requirements
- Full 5-year (NOT pro-rata) warranty from date of purchase

#### Dimensions

6.61" x 2.32" x 1.50" (mounting center - 5.98")

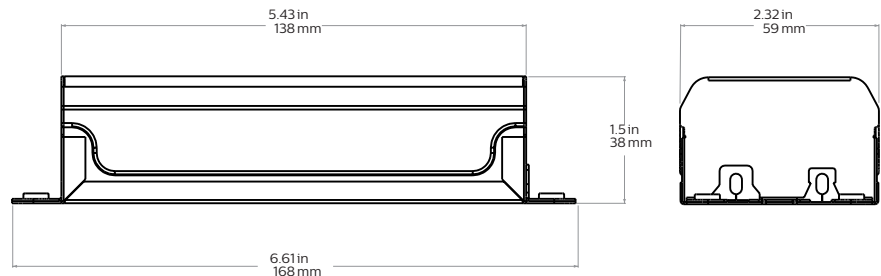

# GTDU Generator Transfer Device

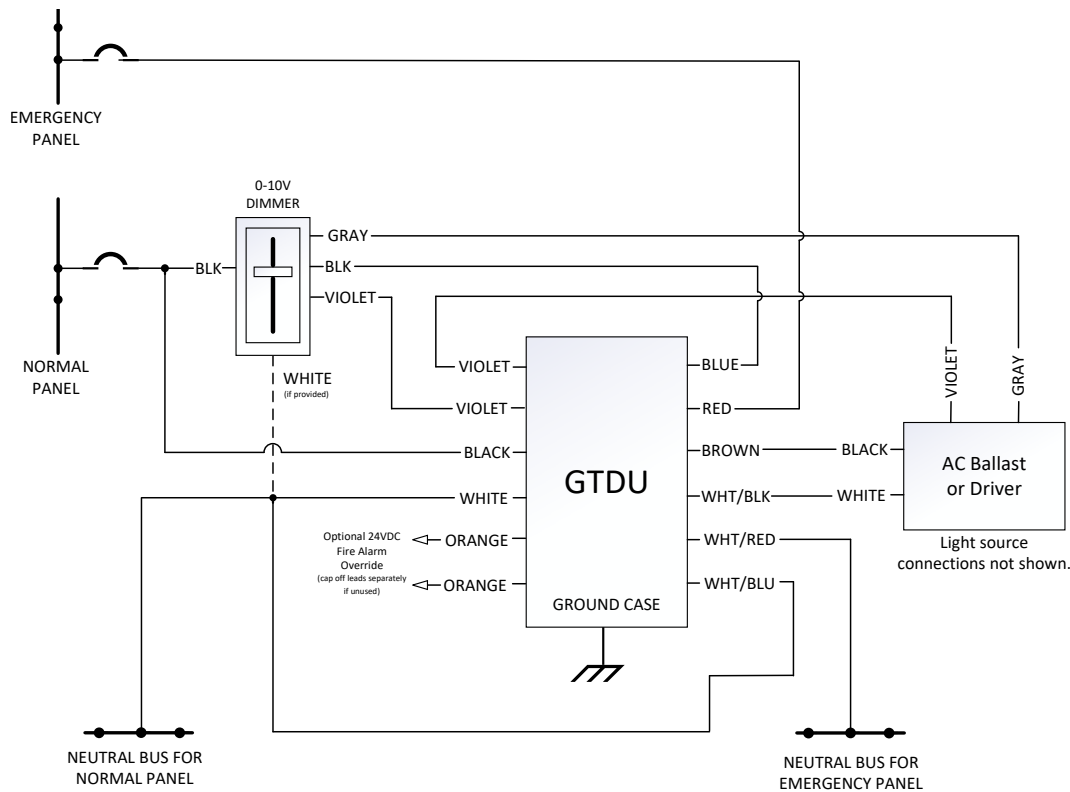

## Application

The GTDU generator transfer device works in conjunction with an auxiliary generator or a central inverter system to power existing incandescent, fluorescent or LED fixtures for egress lighting regardless of fixture wall switch position or dim setting. The device consists of relay switching circuitry in one compact steel case. One generator transfer device per fixture is used to bypass the fixture wall switch and/or dimmer, allowing the building's generator (or central inverter) to operate switchable fixtures at full illumination. The generator transfer device is suitable for indoor or damp locations and for sealed and gasketed fixtures. Recommended applications include: auditoriums, classrooms, hospital, offices or any other location with generator (or central inverter) supplied lighting.

## Operation

The GTDU generator transfer device senses the loss of normal power and switches the AC ballast or driver input power connection to an unswitched, generator (or central inverter) supplied lighting circuit. No routine maintenance is required to keep the GTDU functional; however, like other life safety equipment, it should be checked periodically to ensure that it is working properly.

## Installation

The GTDU generator transfer device does not affect normal fixture operation and comes fully assembled to mount inside, on top of or remote from the fixture ballast (top of fixture and remote installation requires other hardware). In addition to available wiring, the device requires a direct, unswitched connection to a generator (or central inverter) supplied emergency panel and an unswitched source on the same branch circuit as the switched supply (see diagram above).

## UL and Code Compliance

The GTDU has been tested by Underwriters Laboratories in accordance with the standards set forth in UL 924, "Emergency Lighting and Power Equipment," UL 1008, "Automatic Transfer Switches," and is UL Listed for factory or field installation.

## Specification

Generator (or central inverter) supplied egress lighting shall be provided by using a standard incandescent, fluorescent or LED fixture equipped with a Bodine GTDU generator transfer device. The device shall be capable of bypassing the wall switch and/or dimmer when the auxiliary generator (or central inverter) powers lighting. The device shall consist of relay switching circuitry contained in one 6.61" x 2.32" x 1.50" painted steel case; shall operate at 120 through 277 VAC, 50/60 Hz; shall be rated for up to 2 amps maximum (switched load); shall draw 30 mA and 2.3 Watts during normal operation; and shall comply with the current NEC. The device shall be UL Listed for installation inside, on top of or remote from the fixture and shall be warranted for a full five years from date of purchase.

## Warranty

The GTDU generator transfer device is warranted for five (5) full years from date of purchase. Please see detailed warranty information on our website.

The information presented in this document is not intended as any commercial offer and does not form part of any quotation or contract.

