

**ACE-X10-55-190**



**EMERGENCY POWER:** Battery Type/Model No.: FHSBTL LiFePO4 6.4VDC with 3200mAh

Output Power Max	Input Power	Input Current Max	Operating Duration Min.	Battery Charge Time Max.	Output Voltage	Output Current	Battery Voltage	IP Rating	Battery Charge Current	Battery Type
10W	4W	60mA	90min.	24Hrs	15-55V	190mA	6.4V	30	185mA	LiFePO4

**DC Inverter**



**Battery**



**Description:**

This AC Electronics UL Listed Emergency Backup Driver allows a single fixture to be used for both regular and emergency (loss of power) operations. If power fails, this emergency driver switches to “Emergency Mode”. It will then operate the LED modules for 90 minutes at an output voltage in the range of 15-55 V. It can be used in conjunction with switched and

unswitched fixture applications.

During Emergency operation, this driver will drive any LED module that is designed to accept a constant current input of 190mA and has an input voltage in the range of 15-55 VDC.

**Product Features:**

- At least 90 minute operation in emergency mode
- Wide range input voltage - range - 120-277VAC
- Test switch and AC Power-On LED indicator for self-dignostic test
- Operating Temperature Range 0°C Through 55°C
- Maximum Case Temperature 66°C @ 3-Year warranty
- Up to 71% Efficiency
- 5-year USA Backed warranty\*
- Surge Protection - 3kV
- Open/Short/Over-Voltage/Over Temperature protection

**SAFETY:**

- UL and cUL Listed as an LED emergency driver (UL 924)
- UL/cUL Class 2
- UL Classified Field or Factory Installation
- Two-wire universal AC Input
- Self-sensing output voltage adjusts to various LED loads
- Includes battery status indicator
- Long life high temperature LiFePO4 battery
- Warranty: 5 years based on a max. case temp. of ≤60°C\*
- AC Driver maximum output current = 8.0 Amps @ 55VDC

**Product Benefits:**

- Title 24 compatible
- Maintains constant emergency light levels. No power/light degradation throughout the 90-minute runtime.
- Can be used with existing or new fixtures.
- LiFePO4 batteries have a life span up to 10 times longer than that of traditional lead acid batteries. They also operate with much lower resistance and consequently recharge at a faster rate.
- CEC Title 20 Compliant

**Applications:**

- New and existing fixtures
- Emergency back-up installations
- Emergency only fixtures
- With constant current Class 2 LED driver

**5-Year USA-Backed Warranty\***  
**See complete AC Warranty information for details**

**ACE-X10-55-190**



**WIRING:**

Recommended

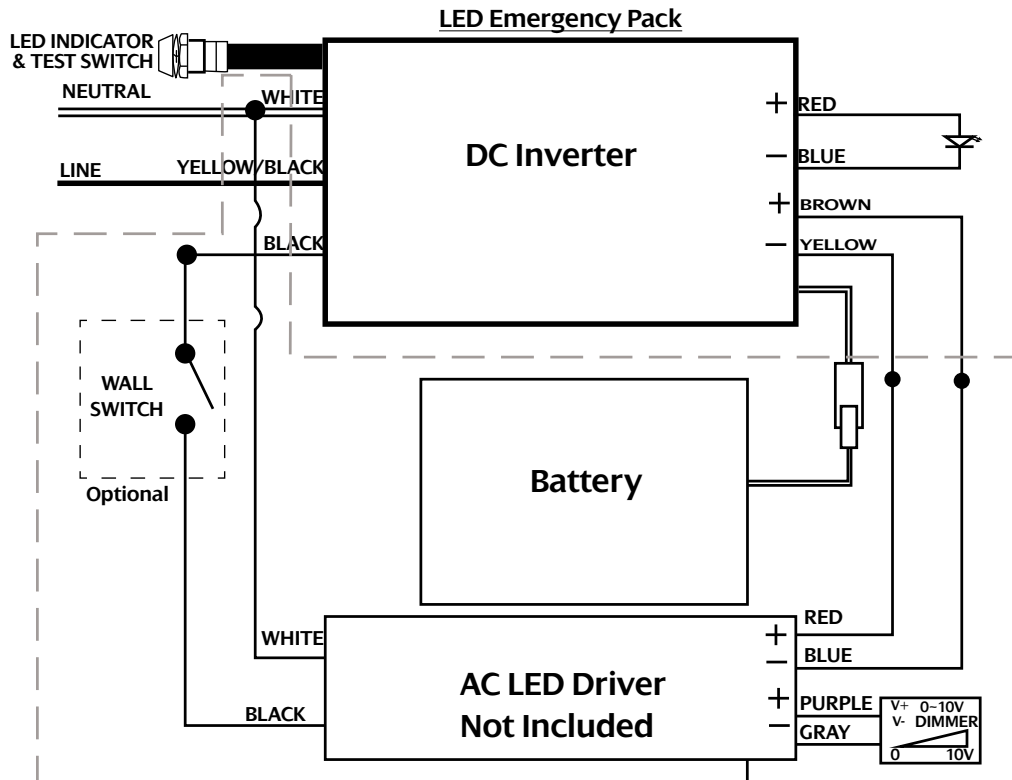

Alternate

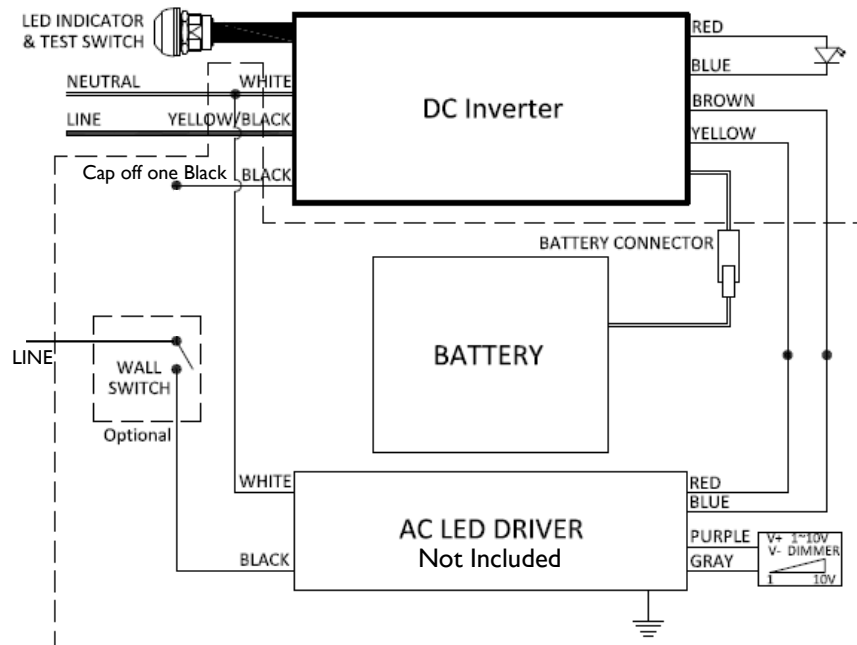

**ACE-X10-55-190**



**ENCLOSURE:**

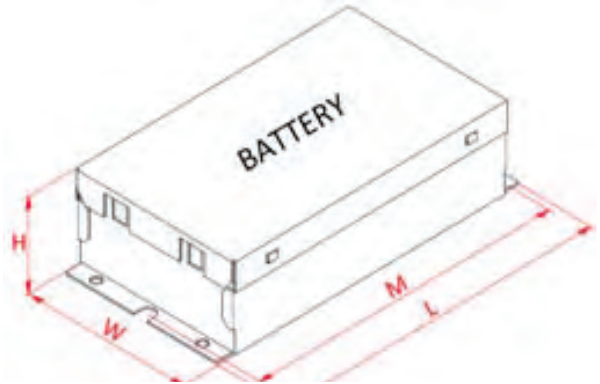
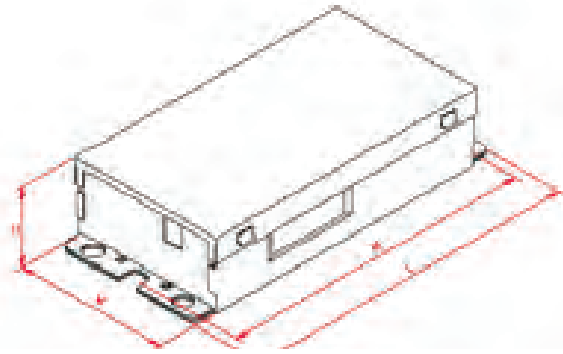

Lead Lengths					
Black	5.9"	Blue	5.9"	Brown	5.9"
White	5.9"	Red	5.9"	Test Switch/ LED Indicator	7.08"/ 23.62"
Yellow/Black	5.9"	Yellow	5.9"		

Dimensions - DC Inverter			
Length	5.23"	Height	1.18"
Width	2.48"	Mounting Length	4.84"

Dimensions - Battery			
Length	3.35"	Height	1.38"
Width	2.44"	Mounting Length	3.07"

**INSTALLATION:**

This emergency backup driver may be used with either a switched or unswitched fixture. If a switched fixture is used, an unswitched hot lead must be connected to this emergency backup driver to allow its battery to charge when AC power is available. The emergency backup driver must be fed from the same branch circuit as the AC powered driver (if used). This emergency backup driver should NOT be installed with fixtures where the ambient tem-

perature may fall below 0 °C (32°F).

- Maximum remote mounting distance to LEDs is 18 feet.
- The emergency backup driver case should be grounded.
- 18 AWG 600V/105°C tinned stranded copper lead-wires required for installation.
- The emergency backup driver shall be installed inside an electrical enclosure.

\*AC Electronics/AC LED Power Designs warrants to the purchaser that each LED Driver will be free from defects in material or workmanship for a period of 5 years when operated at max case temp of up to <60°C when properly installed and under normal conditions of use. See [aceleds.com](http://aceleds.com) for complete warranty policy.

**ACE-X10-55-190**

