

CAUTION: Before installing track head, make sure the hot contact conductor is on the right position.

1. To use track head on one circuit track system, the hot contact conductor at the top of track head must always be in the lower position. To move the lever from the upper to the lower position, simply push lever down.
2. Two circuits track system is designed for use when two separately controlled circuits are needed on one section of track. Each circuit is rated for 2400 watts and will allow you to control two individual sets of fixtures.
3. To use track head on two circuits track system, the hot contact conductor at the top of track head should be in lower position for P1 circuit. For P2 circuit, move the lever from the lower to the upper position.

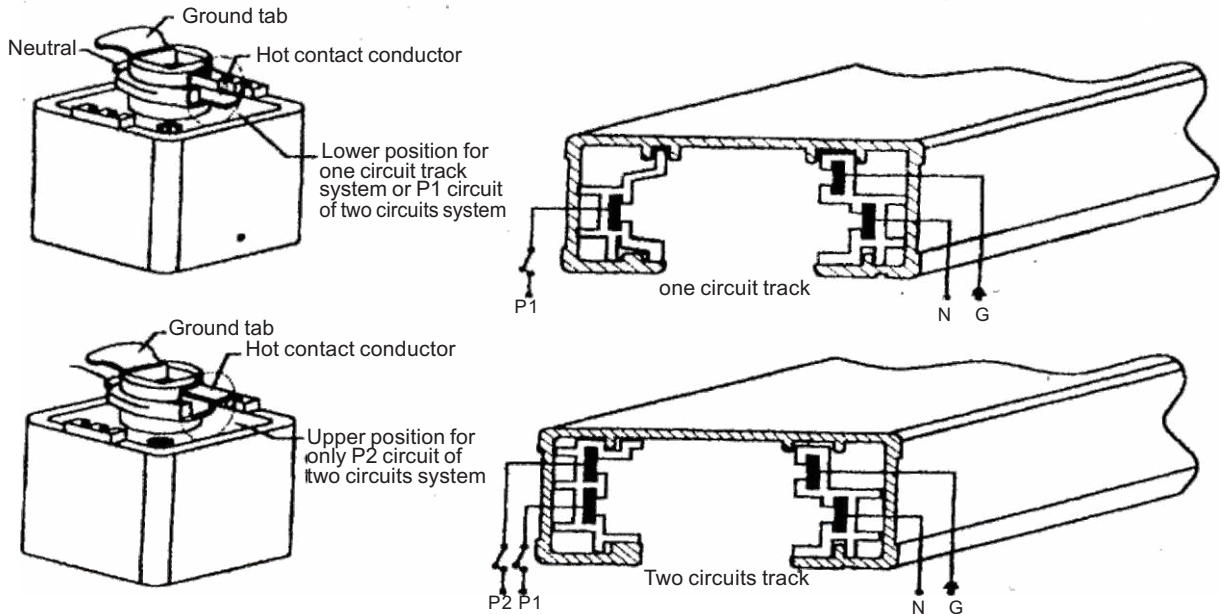

SAVE THESE INSTRUCTIONS

IMPORTANT SAFETY INSTRUCTIONS FOR TRACK LIGHTING

Warning: To avoid the potential risk of fire and shorting, under any circumstances should not you use the connectors and end cap without busbar stoppers (Drawings below with "X" mark) for your track system.

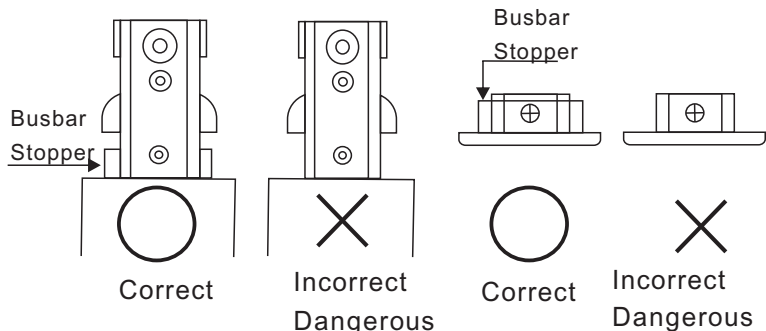

1. Turn off switch at main power source before installing any track or fitting.
2. Before installing lampholder, make sure to refer to the instruction on the back side.
3. Pull down the locking lever and insert "Adaptor contact" into the slot in the track.
4. Rotate adaptor 1/4 turn 90° to locked position. NOTE: Polarity line of lampholder (Grounding tab, polarity side of two fingers) must point to track debossed polarity line so that the debossed polarity line of the track can be aligned with the polarity line (side) of adaptor.

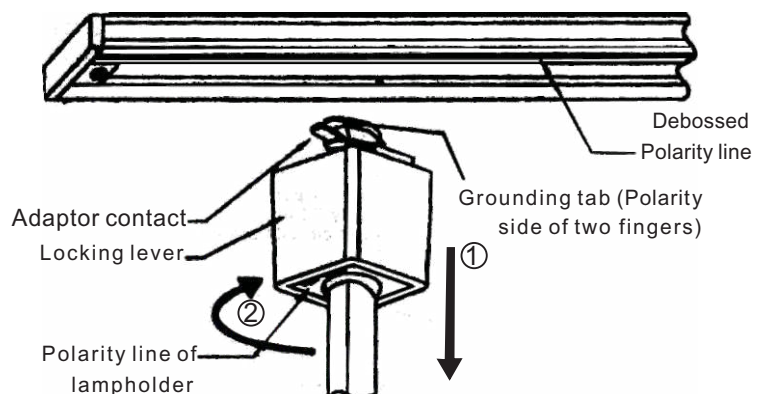

5. To remove, depress the locking lever and turn 90°