

Features & Specifications

INTENDED USE – LED strip light fixtures can be used for warehouses, indoor storage facilities and office buildings. These LED fixtures will yield a significant reduction in energy consumption compared to standard fluorescent fixtures and virtually eliminate ongoing maintenance expenses with a long-lasting lifespan. Designed for use in damp locations, the LED strip light fixture will provide a brighter light output to utility areas and stairwells.

CONSTRUCTION – Steel housing with white baked enamel finish. Resistant to rough vibrations and external impacts. Frosted lens protects the LEDs and provides even light distribution.

OPTICS – High-performance LEDs maintain a 4,940 Lumen output at 4000K for 50,000 hours of use.

ELECTRICAL – Input voltage of 120-277 VAC, 50/60Hz. Consider adding a surge protector to protect your fixtures from power surges in your electrical system as an added insurance policy to your investment.

INSTALLATION - Designed for surface or suspended chain mounting; individually or in a continuous row. Dimmable down to 10% using a 0-10V driver.

LISTINGS – UL Certified to safety standards for damp locations. Rated for -4°F to 122°F ambient temperature.

WARRANTY – 3-year warranty. PLT products that are damaged or defective will be repaired or replaced at PLT's choosing for a period of 3 years. Contact 1-800-624-4488 for more information.

LED Strip Lights

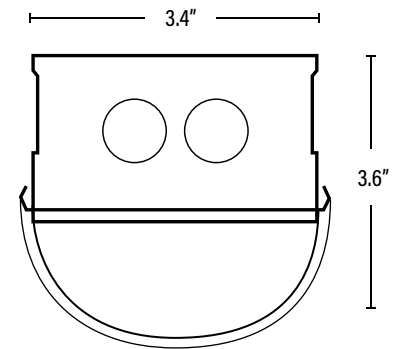

Length	96"
Width/Diameter	3.4"
Height	3.6"
Weight (Lbs)	--

Line drawings may not be to scale and are for general reference only.

SKU #	Kelvin	Lumens	CRI	Wattage	Voltage	DLC	Mounting	Life Hours	Warranty
PLT-20136	4000	4,940	80	38	120-277	NO	Surface	50,000	3 YEAR