

# ProLED<sup>®</sup> HID Retrofit Installation Instructions

## IMPORTANT

READ INSTRUCTIONS CAREFULLY BEFORE INSTALLING. KEEP THESE INSTRUCTIONS FOR FUTURE REFERENCE. ProLED lamps must be wired in accordance with the National Electrical Code and all applicable local codes. Proper grounding is required for safety. THIS PRODUCT MUST BE INSTALLED IN ACCORDANCE WITH THE APPLICABLE INSTALLATION CODE BY A QUALIFIED ELECTRICIAN WHO IS FAMILIAR WITH THE CONSTRUCTION AND OPERATION OF THE PRODUCT AND THE HAZARDS INVOLVED.

**WARNING** - Risk of fire or electric shock. ProLED HID Retrofit Lamp installation requires knowledge of luminaires and electrical systems. If not qualified, DO NOT attempt installation. Contact a qualified electrician.

**WARNING** - All the LED lamp models below can be used for dry or damp locations, DO NOT use where directly exposed to water.

**WARNING** - Not for use with dimmers.

**WARNING** - Added weight of the device may cause instability of a free-standing portable luminaire.

**OPERATING TEMPERATURE:** -20° C to 60° C (-4° F to 140° F)

This device is not intended for use with emergency exits.

## Warranty Information:

This product is warranted for 5 years from the date of purchase. If this product does not perform to the specifications supplied on this package, send an email to warranty or write to the address below for product return and replacement. This replacement is the sole remedy available. Liability for incidental or consequential damage is expressly excluded.

## Product Size:

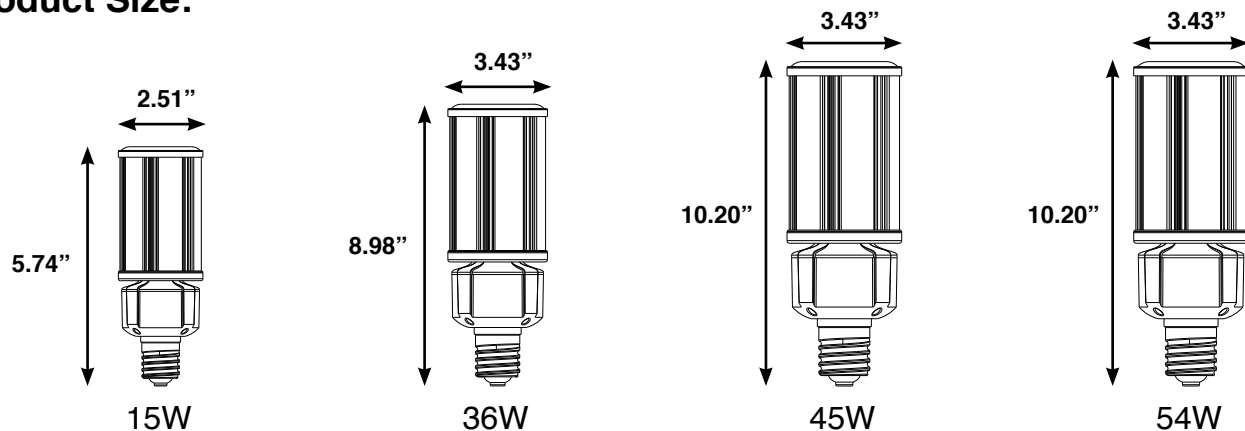

## Installation Steps:

- 1 TURN OFF THE POWER BEFORE INSTALLATION.
- 2 As shown in *Figure 1*; Remove the old Ballast, Capacitor and Ignitor (if existing).

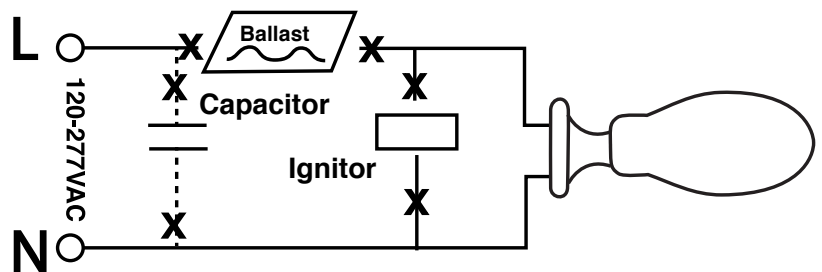

Fig 1

## Installation Steps Continued:

- 3 As shown in *Figure 2*;  
Connect A/C line voltage wires directly to E26 socket.  
(Reattach or replace ground lead if one is needed)



Fig 2

- 4 As shown in *Figure 3*;  
Screw the LED lamp onto the corresponding socket.

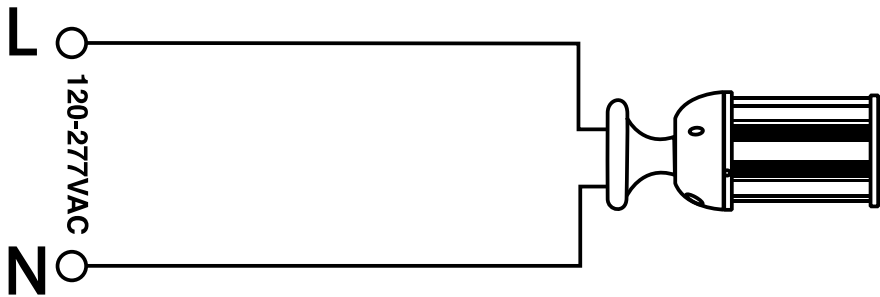

Fig 3