



**Always have a qualified electrician do your electrical work.
Switch off power before starting the installation.**

PLEASE REVIEW THE INSTRUCTIONS AND WARNINGS LISTED BELOW PRIOR TO INSTALLATION.

This LED tube is intended to replace fluorescent tube lamps with an ANSI designation 32W/48T8/RS, 32W/48T8

WARNINGS:

- Risk of fire/ electrical shock
- LED Hybrid Tube installation requires knowledge of luminaire electrical systems. (If you are not a qualified electrician, please do not attempt installation and contact a qualified electrician.)
- Risk of electric shock – disconnect power at source before installation
- Do not make or alter any open holes in an enclosure of wiring or electrical components during installation.
- If lamp or luminaire exhibits abnormal operation (buzzing, flickering, minimal light, etc.), turn off power, remove lamp and contact us. For more information visit www.eurilighting.com or call our toll-free number 1-888-743-5766.

CAUTIONS:

- Do not use with dimmers.
- Do not look directly at the operating LED Hybrid Tube.
- Do not touch this product with wet hands.
- Do not disassemble, repair or alter lamp.
- Designed for indoor application only.
- Suitable for damp locations.
- The luminaires shall be grounded.
- Be careful not to touch the lamp pins to the metal housing when installing.
- This Device is not intended for use with emergency exits or emergency lights.

TYPE A ASSEMBLY INTRODUCTION

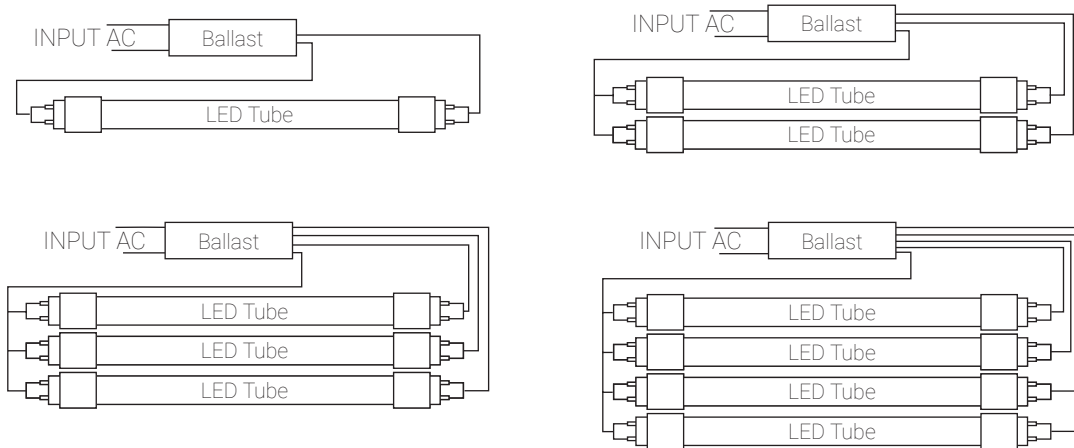

TYPE A INSTALLATION GUIDE

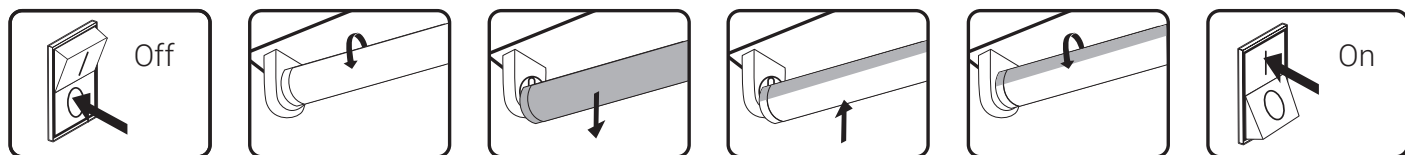

- 1.
2. Fluorescent
3. Fluorescent
4. LED T8 Hybrid
5. LED T8 Hybrid
- 6.

Instructions:

1. Switch off power to the luminaire.
2. Remove diffuser (if provided)
3. Remove the existing fluorescent lamps from the luminaire
4. Install the LED tube lamp
5. Install diffuser (if removed in step 2)
6. Switch on power to the luminaire

This product may not be compatible with all ballast, please visit our website for ballast compatibility list.



TYPE B1 ASSEMBLY INTRODUCTION

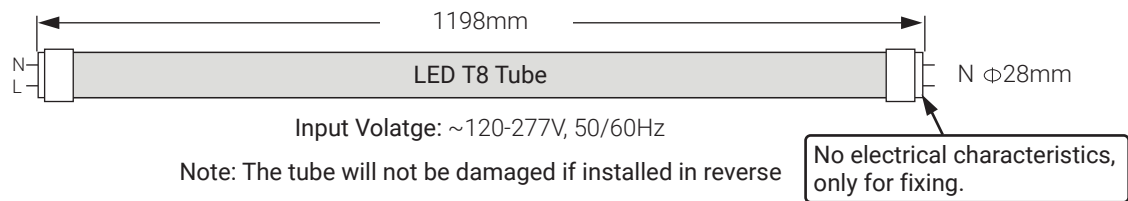

TYPE B3 ASSEMBLY INTRODUCTION

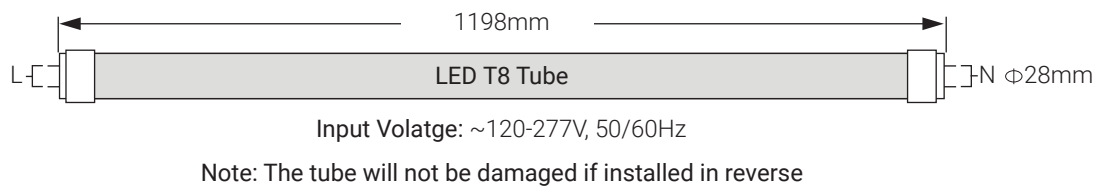

Instructions

1. Disconnect power of luminaire

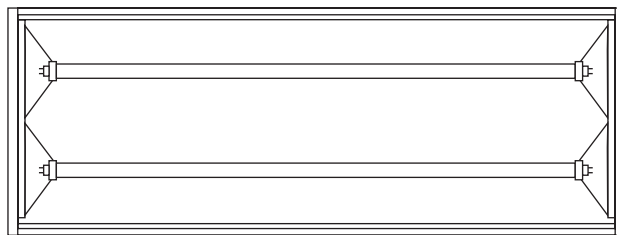

*Disconnect power to luminaire or circuit (if possible). Ensure all power is off by using a voltmeter or other method to confirm.

2. Remove existing tube lamp(s)

- a) Remove troffer lens, if present
- b) Remove existing fluorescent by rotating one quarter turn and sliding lamp(s)
- c) Remove ballast cover (cover may be secured with screws or tabs)

3. Retrofit luminaire

a) Remove luminaire with inductive ballast

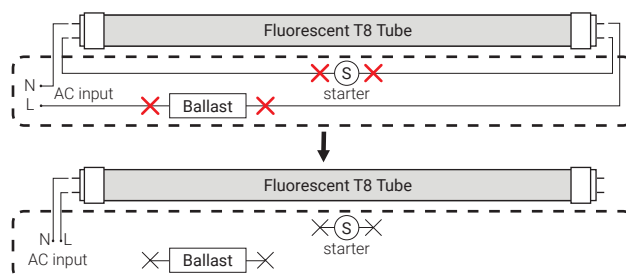

*Disconnect the wires between starter and ballast according to the left figure.

*Connect two wires to branch circuit L and N according to the left figure.

This product may not be compatible with all ballast, please visit our website for ballast compatibility list.



b) Retrofit luminaire with electronic ballast

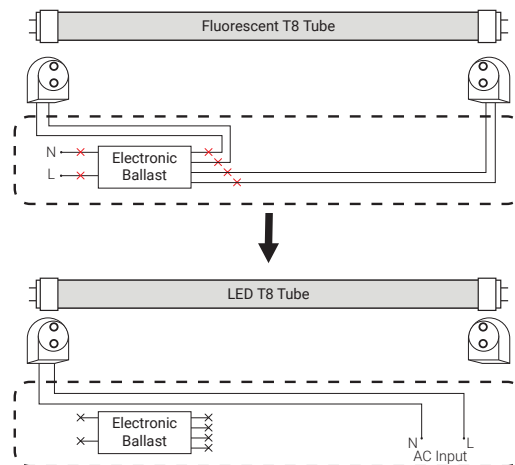

Disconnect the wires between starter and ballast according to the left figure.

Connect the two wires to branch circuit L and N according the left figure.

c) Retrofit luminaire with two lamps and one electrical ballast

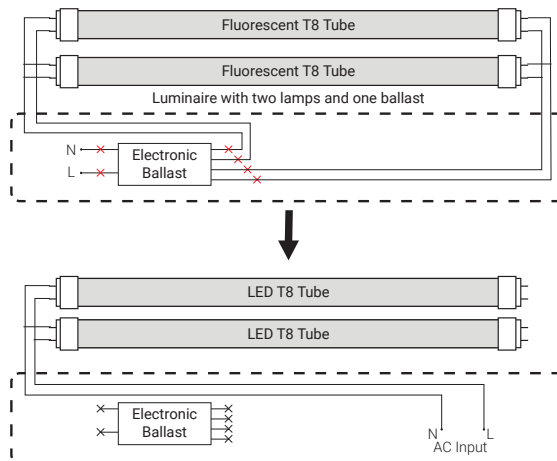

Disconnect the wires between starter and ballast according to the left figure.

Connect the two wires to branch circuit L and N according the left figure.

4. Insert LED Tubes

- Read Label on the LED tube to ensure the power end of LED is aligned with powered tube socket, then insert single-end-power LED lamp in the normal way by sliding pins into sockets and rotating a quarter then until LED tube locks in place.
- LED lamps are now fully installed
- Replace troffer lens, if present
- After modification complete. Attach the replacement marking and cautionary label to a visible place on the luminaire and keep it visible after installation

5. Restore the power of luminaire

Restore power to circuit/luminaire and test light. If necessary, adjust position of LED tube, and enjoy your new tube light!

This product may not be compatible with all ballast, please visit our website for ballast compatibility list.