



I-42-EM-B

TBTS SERIES AC
10W–42W RAPID START
4 PIN COMPACT LAMP
EMERGENCY LIGHTING EQUIPMENT

INSTRUCTION MANUAL

IMPORTANT SAFEGUARDS

When using electrical equipment, basic safety precautions should always be followed, including the following:

READ AND FOLLOW ALL SAFETY INSTRUCTIONS

1. **CAUTION** – To prevent electrical shock, do not mate unit connector until installation is complete and A.C. power is supplied to the unit.
2. **CAUTION** – This fixture provides more than one power supply output source. To reduce the risk of electrical shock, disconnect both normal and emergency sources by turning off the A.C. branch circuit and by disconnecting the unit connector.
3. **CAUTION** – This is a sealed unit. The integral, high temperature Ni-Cad battery is not replaceable. Replace the entire unit when necessary and recycle or dispose of the nickel-cadmium battery properly.
4. **DO NOT USE OUTDOORS.** The **I-42-EM-B** is for use with grounded, UL Listed, damp location rated, indoor fixtures. Not for use in heated air outlets or hazardous locations.
5. The **I-42-EM-B** requires an unswitched A.C. power source of either 120 or 277 volts. Properly cap the unused A.C. lead.
6. When the **I-42-EM-B** is installed on the same branch circuit, refer to Illustration 3, Figures A and B for input wiring. When installed on separate branch circuits, refer to Illustration 3, Figures C and D for input wiring. Per NEC, the **I-42-EM-B** and A.C. ballast must be on the same panel board.
7. Do not mount near gas or electric heaters.
8. The **I-42-EM-B** should be mounted in locations and at heights where it will not readily be subjected to tampering by unauthorized personnel.
9. The **I-42-EM-B** will cold strike and operate *one* 10W through 42W, or *two* 10W through 18W, 4-pin Rapid Start compact fluorescent lamps. Contact customer service for additional lamp usage.
10. The **I-42-EM-B** is compatible with most electronic A.C. ballasts (including multiple lamps) as follows:
Electronic ballasts – one or two lamp emergency operation.
11. Suitable for use in damp locations and in enclosed and gasketed fixtures.
12. When used in conjunction with enclosed and gasketed fixtures, the **I-42-EM-B** is suitable for mounting in the ballast compartment only.
13. For use in 0° C minimum, 50° C maximum ambient temperatures.
14. The use of accessory equipment not recommended by the manufacturer may cause an unsafe condition.
15. Do not use this equipment for other than intended use.
16. Install in accordance with the National Electrical Code and local regulations.
17. Installation and servicing should be performed by qualified personnel.
18. Lighting fixture manufacturers, electricians and end users need to ensure product system compatibility before final installation.

SAVE THESE INSTRUCTIONS



THIS UNIT CONTAINS A
RECHARGEABLE NICKEL-CADMIUM BATTERY.
PLEASE RECYCLE OR DISPOSE OF PROPERLY.

INSTALLATION INSTRUCTIONS

CAUTION: Before installing, make certain the A.C. power is off and the I-42-EM-B unit connector is disconnected.

1. LAMPS OPERATED

Refer to the chart for the type of lamp(s) operated and the number of lamps to be operated in the emergency mode.

If you have any questions regarding specific lamps, contact Customer Service.

The 6" violet leads provide the lamp selection option. The unit is shipped from the factory with the leads disconnected and capped. When used with particular lamp types, violet leads should be connected to one another. Refer to the chart for lamp selection options.

OPTION	LAMP	TYPE	EMERGENCY OPERATION	VIOLET LEADS
1	10W-18W	Compact	One Lamp	Connected
2	26W-42W	Compact	One Lamp	Disconnected
3	10W-13W	Compact	Two Lamp	Connected
4	18W	Compact	Two Lamp	Disconnected
5	18W	Long Compact	One Lamp	Connected
6	24W	Long Compact	One Lamp	Disconnected
7	36W	Long Compact	One Lamp	Disconnected

2. MOUNTING THE I-42-EM-B

Mount the **I-42-EM-B** in the ballast channel or enclosed wireway so the wire leads are not exposed, at least 1/2" away from the A.C. ballast(s). Refer to *Illustration 1*. For mounting the **I-42-EM-B** on top of the fixture, use the optional TMK-80 mounting accessory for covering the wires that enter the fixture. Refer to *Illustration 2*.

When battery packs are remote mounted, consult Customer Service for the maximum allowable distance between the battery pack and the lamp(s).

3. INSTALLING THE THREADED BODY TEST SWITCH (TBTS)

Select a convenient location on the side of the fixture so that the **TBTS** can be seen after installation. Allow for proper clearance and drill or punch a 1/2" hole. Remove the nut from the **TBTS**. Push the **TBTS** housing into the 1/2" hole and secure with the nut. Connect the LED wires from the unit to the **TBTS** (Red/Black or Red w/tag to Red, and White/Red to White).

4. WIRING

- When the **I-42-EM-B** is installed on the same branch circuit, refer to *Illustration 3*, Figures A and B for input wiring. When installed on separate branch circuits, refer to *Illustration 3*, Figures C and D for input wiring. Per NEC, the **I-42-EM-B** and A.C. ballast must be on the same panel board.
- The **I-42-EM-B** requires an **unswitched** A.C. power source of either 120 or 277 volts; therefore, when used with switched fixtures, the **I-42-EM-B** input must be wired ahead of the switch. Refer to *Illustration 3* for switched and unswitched fixture wiring diagrams.
- Refer to the wiring diagrams on the back page for the proper wiring. For wiring diagrams of ballasts not shown, consult our Customer Service.

5. LABELS

Attach the appropriate labels adjacent to the **TBTS**. Annotate Re-lamping label for lamp type and wattage. The Caution and the Re-lamping labels must be on the fixture in a readily visible location to anyone attempting to service the fixture.

Illustration 1 - Twin Lamp Fixture

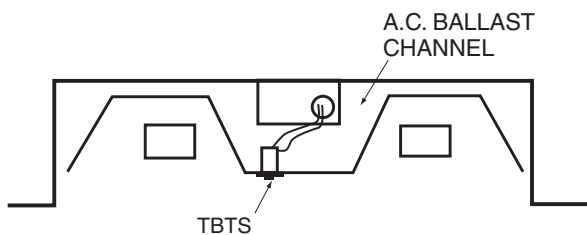
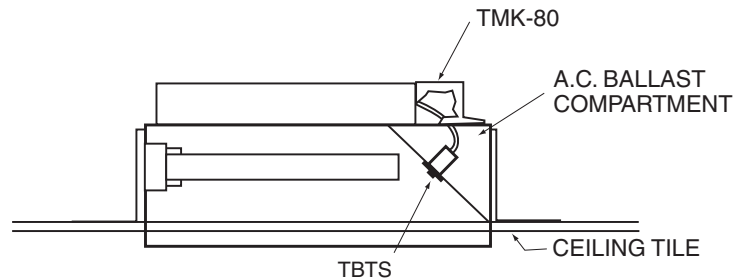
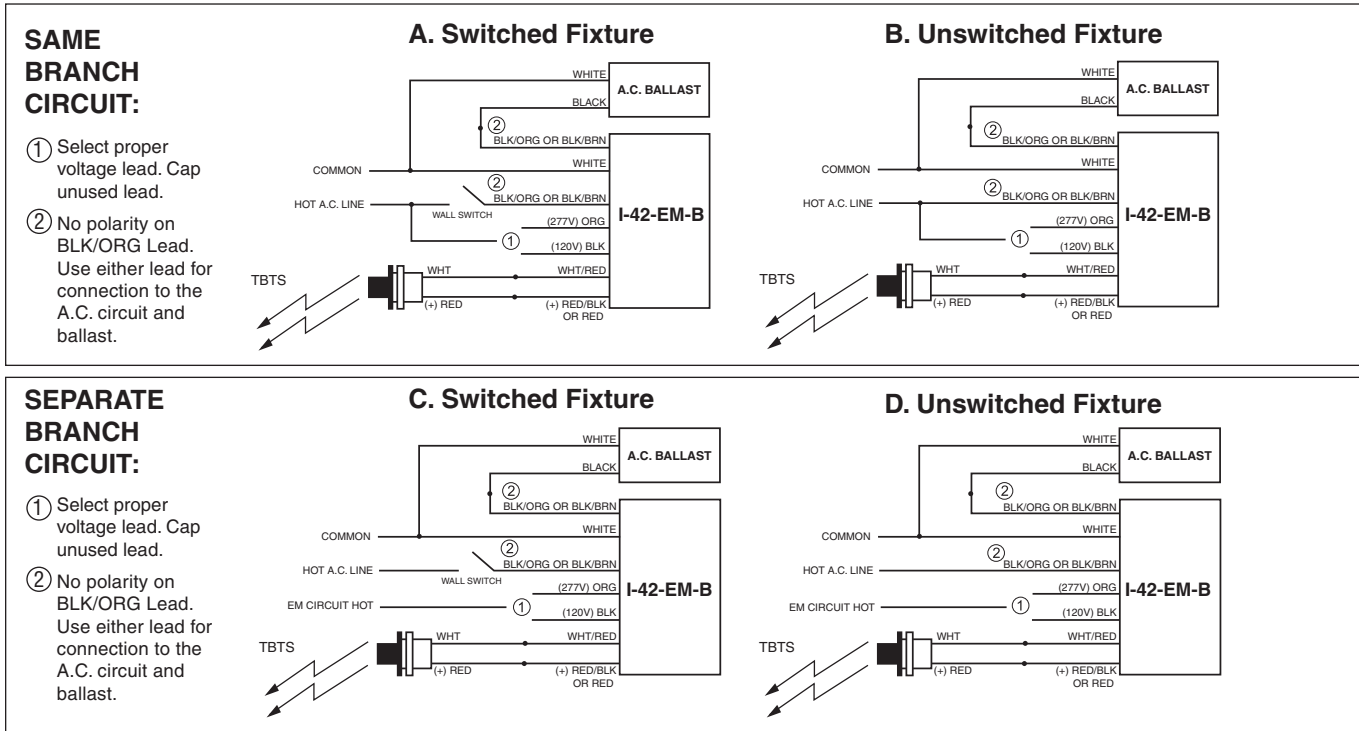

Illustration 2 - Top Mounting with TMK-80 Option



INSURE WIRING IS IN ACCORDANCE WITH THE NATIONAL ELECTRICAL CODE AND LOCAL REGULATIONS.

Illustration 3



6. COMPLETING INSTALLATION

- When the installation is complete, switch the A.C. power on and join the **I-42-EM-B** unit connector.
- Replace the ballast cover, fixture lens and other fixture hardware.

OPERATION

Normal Mode – A.C. power is present. The A.C. ballast operates the fluorescent lamp(s) as intended. The **I-42-EM-B** is in the standby charging mode. The **TBTS** will be lit providing a visual indication that the battery is being charged.

Emergency Mode – The A.C. power fails. The **I-42-EM-B** senses the A.C. power failure and automatically switches to the *Emergency Mode*. One lamp or two lamps are illuminated, at reduced output, for a minimum of 90 minutes. When the A.C. power is restored, the **I-42-EM-B** switches the system back to the *Normal Mode* and resumes battery charging. See page 1 of the Instruction Manual.

TESTING & MAINTENANCE

Pressing the red lens on the **TBTS** turns off the light on the **TBTS** and forces the unit into emergency mode, interrupting power to the designated A.C. ballast. The emergency lamp is now being lit by the **I-42-EM-B** unit. After releasing the **TBTS**, the fixture returns to normal operation after a momentary delay. To simulate a “BLACK OUT” use the circuit breaker to turn off A.C. power.

Initial Testing – Allow the unit to charge approximately 1 hour, then conduct a short discharge test by depressing the test switch. Allow a 24 hour charge before conducting a one hour test.

The **I-42-EM-B** is a maintenance free unit, however, periodic inspection and testing is required. NFPA 101, Life Safety Code, outlines the following schedule:

Monthly – Insure that the **TBTS** light is illuminated. Conduct a 30 second discharge test by depressing the **TBTS**. One lamp or two lamps should operate at reduced output.

Annually – Insure that the **TBTS** light is illuminated. Conduct a full 1½ hour discharge test. The unit should operate as intended for the duration of the test.

“Written records of testing shall be kept by the owner for inspection by the authority having jurisdiction.”

SERVICING SHOULD BE PERFORMED BY QUALIFIED PERSONNEL.

Consult Customer Service for current warranty information.

TYPICAL WIRING DIAGRAMS

Use in conjunction with Rapid Start ballasts and 4 pin lamps only

Wiring and Troubleshooting Tips are available on-line

1. ONE LAMP RAPID START BALLAST

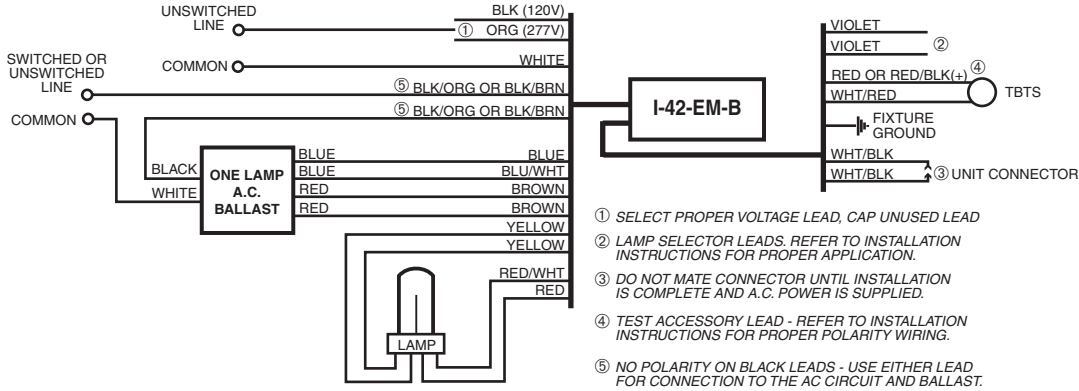

2. TWO LAMP RAPID START BALLAST WITH ONE LAMP EMERGENCY OPERATION

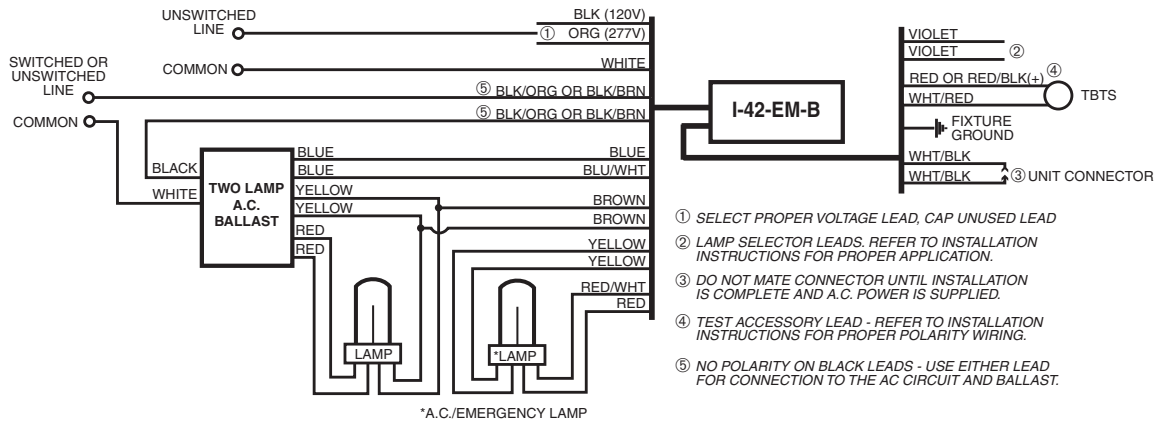

3. TWO LAMP RAPID START BALLAST WITH TWO LAMP EMERGENCY OPERATION

