

Features & Specifications

PLT & FLOOD LIGHTS

INTENDED USE – Combined with LED technology, these flood lights have a unique optical design equal to HID light sources yet consume less power, last longer, and are more energy efficient. They are often used to illuminate outdoor areas during low-light conditions. When you own a business, warehouse, or commercial space, LED flood lights are an effective way to protect the outside area and ensure that it stays brightly illuminated both day and night. Having your area illuminated lessens the chance of break-ins and helps ensure the safety of everyone who works in the area. In most cases, flood lights are used for security and landscape lighting purposes. However, lower-powered flood lights can be used indoors to create lighting effects and to help illuminate large event spaces.

CONSTRUCTION – High-density aluminum alloy housing with a bronze corrosion-resistant powder coat finish for lasting durability. Transparent and weather resistant lens. Housing is sealed against moisture and environmental contaminants (IP65 rated). Designed to protect each fixture from inclement weather.

OPTICS – High-performance LEDs maintain a 6790 Lumen output at 5000K for up to 35,000 hours. Use lower Lumen flood lights (5,000-7,000 lumen range) for indoor and soft setting applications and higher Lumen flood lights for commercial use.

ELECTRICAL – Integral heat sink, Input voltage of 120-277 VAC, 50/60Hz. Consider adding a surge protector to protect your fixtures from power surges in your electrical system as an added insurance policy to your investment.

MOUNTING – Trunnion option for adjustable wall, pole, or roof mounting; ideal for flag and sign lighting. Slipfitter option for pole top or bullhorn mounting; ideal for landscape and signs. Adjustable knuckle mount with optional ground stake for landscape applications.

LISTINGS – UL Certified to safety standards for wet locations. Rated for -40°C to 45°C ambient temperature. DesignLights Consortium® (DLC) qualified product. IP-65 Rated.

WARRANTY – 5-year warranty. PLT products that are damaged or defective will be repaired or replaced at PLT's choosing for a period of 5 years. Contact 1-800-624-4488 for more information.

ADD-ONS – Pair with timers, photocells, and motion sensors for hassle free bright nighttime lighting and energy savings during the day without needing to worry about manually turning the fixture on and off. If pairing with a photocell, it must be LED compatible in order to operate properly. If using a conventional photocell, be sure to replace it with one rated for use with LEDs. While conventional light sensors will still work with LED fixtures at first, they will burn out prematurely. The same is true for motion sensors.

Photocells: Detects the presence of visible light, infrared (IR) and/or ultraviolet (UV) energy and turns on or off according to those measured light levels. The most commonly used type of control for wall packs and lighting fixtures.

Timers: An electronic component which adjusts the when a light operates according to pre-set schedule. Consistently turns lights on or off for a specified time frame.

Motion Sensors: Senses occupancy of a space and turns lights on and off when movement is detected. Ideal for areas where the traffic of occupants fluctuates. Passive Infrared (PIR) sensors detect body heat (infrared energy). Typically used in exterior parking and structure applications and requires a direct line of sight to function properly. Ultrasonic sensors send out pulses of ultrasonic waves and measure the reflection of an object. Not regularly used for outdoor applications due to high sensitivity to moving objects such as trees and small animals.



Dimensions
Height: 15.6 in.
Width: 12.6 in.
Depth: 3.27 in.
Weight: 9.3 lbs

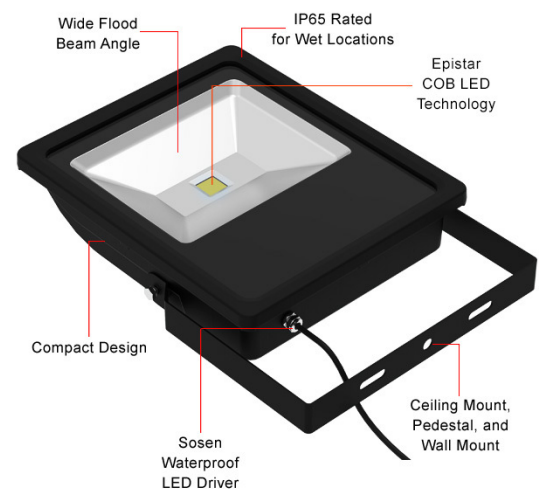

SKU#	Kelvin	Lumens	Angle	Wattage	Voltage	DLC?	Mounting	Life Hours	Warranty
PLT-10634	5000	6790	120	70	120-277	Yes	Ceiling/Wall	35,000	5 Year

Dimension (Unit:mm):

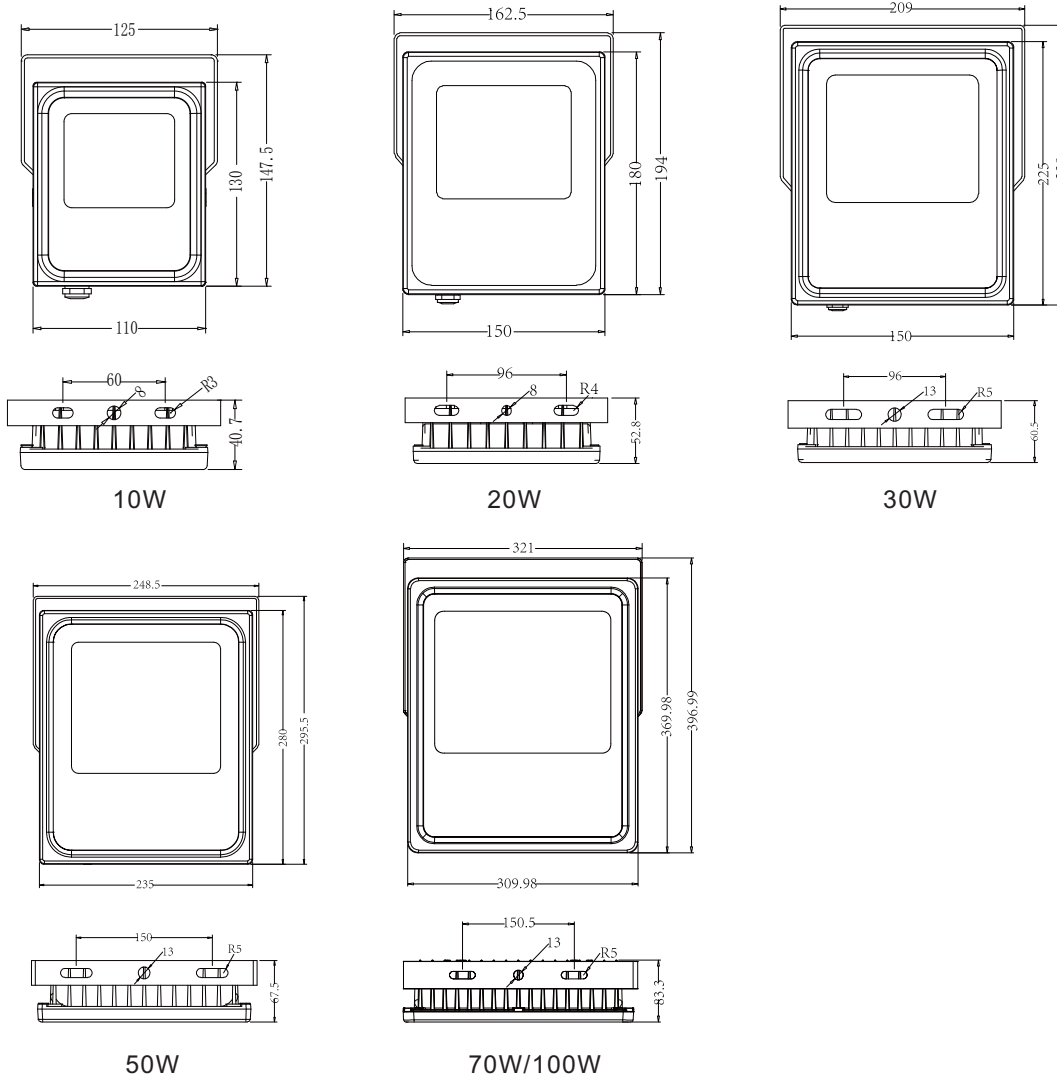

Installation:

1.surface mounting

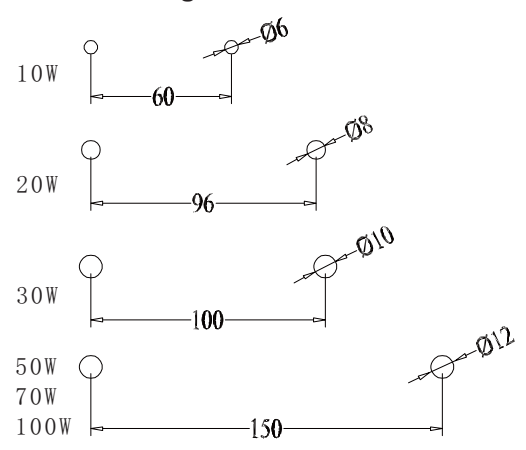

ceiling installation

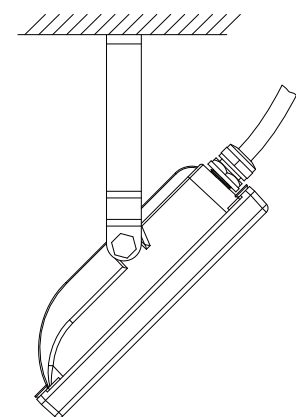

Pedestal installation

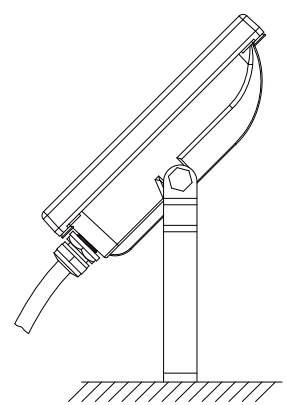

Step 1: Drill holes on installation surface to install M6/M8/M10/M12 bolt

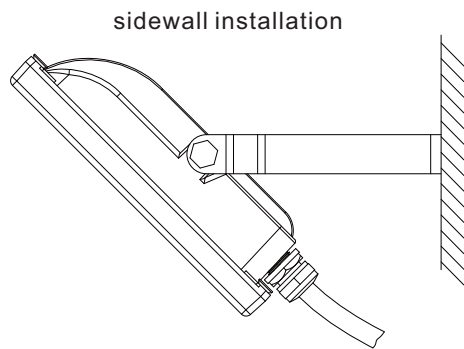

Step2: Install lamp on expansion bolts

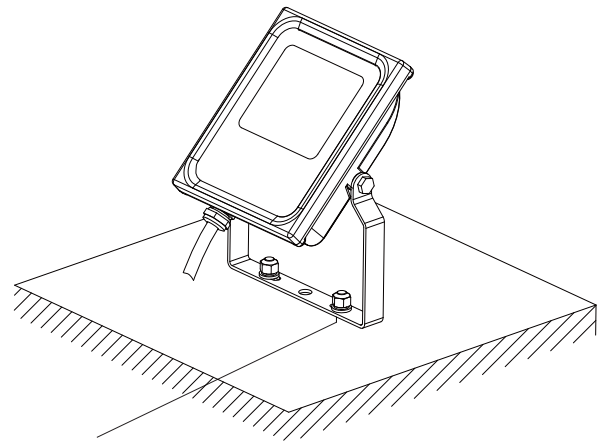

Step3: Install flat gasket, spring washer and nut to fasten bracket and expansion bolts

Packing information :

10W

Net weight: 0.70 KG

Gross weight 0.75KG

Packing box dimension: 137*62*195mm

Outer carton dimension:

565*405*205mm (24 pcs/carton)

Total weight:19.0KG

20W

Net weight: 1.1 KG

Gross weight 1.2KG

Packing box dimension: 173*70*218mm

Outer carton dimension:

535*453*230mm (18 pcs/carton)

Total weight:22.5KG

30W

Net weight: 1.7 KG

Gross weight 1.8KG

Packing box dimension: 219*78*258mm

Outer carton dimension:

533*455*255mm (12 pcs/carton)

Total weight:22.7KG

50W

Net weight: 2.5 KG

Gross weight 2.7KG

Packing box dimension: 257*87*314mm

Outer carton dimension:

540*275*335mm (6 pcs/carton)

Total weight:17.3KG

70W

Net weight: 4.2 KG

Gross weight 4.7KG

Packing box dimension: 340*120*420mm

Outer carton dimension:

500*440*360mm (4 pcs/carton)

Total weight:19.0KG

100W

Net weight: 4.5 KG

Gross weight 5.0KG

Packing box dimension: 340*120*420mm

Outer carton dimension:

500*440*360mm (4 pcs/carton)

Total weight:22.0KG

Installation requirement:

- 1.Please prepare two sets of bolts to install the light;
- 2.Power off before installation;
- 3.Make sure the installed surface can endure the weight of light, and fix the light on the installed surface securely (according to installation diagram);
4. Connect light wire to power wire, seal the joint with insulation.

Notice :

- 1.Please read the specification first, to make sure the service environment matches the conditions in the specification before using;
- 2.Please confirm input voltage, frequency before using;
3. The lamp must be installed by professionals;
4. The lamp can't be used if the power wire, housing are damaged;
5. The lamp can't be maintained by non-professionals;
- 6.If the exterior flexible cable or wire is damaged, it must be exchanged by the supplier, its agent or other relevant qualified personnel to avoid dangers;
- 7.Using environment: -20°C-35°C.