

**READ AND FOLLOW ALL SAFETY INSTRUCTIONS!  
SAVE THESE INSTRUCTIONS AND DELIVER TO OWNER AFTER INSTALLATION**

## IMPORTANT SAFETY INSTRUCTIONS

### **▲WARNING**

To reduce the risk of death, injury or property damage from fire, electric shock, cuts, abrasions, falling parts, and other hazards:

- Service of the equipment must be performed by qualified service personnel.
- Installation and maintenance must be performed by a person familiar with the construction and operation of this product and any hazards involved. All applicable codes and ordinances must be followed.
- Read this document before installing, servicing, or maintaining this equipment or installing a lamp. These instructions do not cover all installation, service, and maintenance situations. If your situation is not covered, or if you do not understand these instructions or additional information is required, contact *Lithonia Lighting* or your local *Lithonia Lighting* Distributor.
- Read and follow all warnings and instructions provided by the lamp manufacturer.

### **▲WARNING**

Before installing, servicing, or maintaining this equipment, follow these general precautions.

To reduce the risk of electrocution:

- Make sure the equipment is properly grounded.
- Always de-energize the circuit and/or equipment before connecting to, disconnecting from, or servicing the equipment.

To reduce the risk of fire:

- Keep material away that can burn from hot lamp.
- Make sure lamps are correctly installed.
- Use supply conductors with a minimum installation temperature rating as specified on equipment.

To reduce the risk of personal injury from cuts, abrasions, or falling parts:

- Wear gloves to prevent cuts or abrasions from sharp edges when removing from carton, handling and maintaining this equipment.
- Do not use abrasive materials, glass cleaners or other solvents on reflector or lens. These substances may damage equipment and cause parts to eventually break and fall.
- Do not install a damaged fixture.

**▲CAUTION:** Observe lamp manufacturer's recommendations and restrictions on lamp operation, including but not limited to ballast type, burning position, replacement and cycling. Use only lamps that comply with applicable ANSI standards.

**NOTICE:** If lamp is marked  it contains mercury. Follow disposal laws. See [www.lamprecycle.org](http://www.lamprecycle.org)

*Lithonia Lighting*, a division of *Acuity Brands Lighting*, Inc., assumes no responsibility for claims arising out of improper or careless installation or handling of this product.

**SAVE THESE INSTRUCTIONS**

**Installation Instructions**  
**TWA TWAC**

Delivery: Upon receipt of fixture and accessories (packed separately), thoroughly inspect for any freight damage. All damage should be reported to the delivery carrier. Compare the catalog description listed on the packing slip with the fixture label on the inside of the housing to be sure you have received the correct merchandise.

<b>TWA</b>	<b>TWAC</b>	<ol style="list-style-type: none"> <li>1. Loosen the 2 captive lens screws and remove front cover. (Figure 1) Remove cartoned lamp (if provided).</li> <li>2. Loosen 2 captive screws from component cover and hinge downward. (Figure 2)</li> </ol> <p><b>▲ CAUTION: APPLY A CONTINUOUS BEAD OF WEATHER - PROOF CAULKING BETWEEN MOUNTING PLATE AND WALL TO ENSURE WEATHER - TIGHT INTEGRITY OF ELECTRICAL COMPONENTS.</b></p>
------------	-------------	---

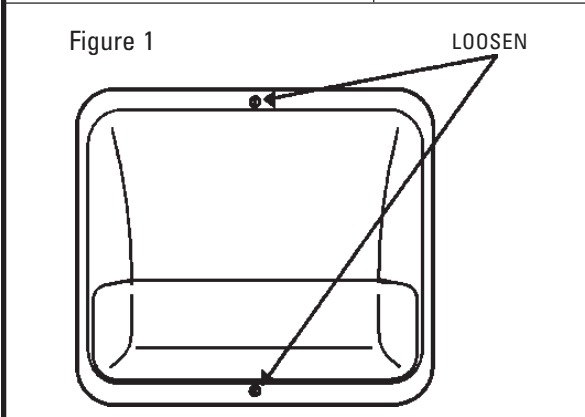

3. Preferred mounting method: Punch out the 3/8" knockouts (3) in the cast back plate. Position cast back plate against the wall and mount with 1/4" screws (by others). (Figure 2)
4. Alternate mounting method: Attach adaptor strap to outlet box with 2 screws. Make sure strap is attached so screws are somewhat horizontally opposed from each other (Figure 3). Position cast back plate such that the 2 adaptor strap screws fit through the keyhole slots in the cast back plate. Rotate entire assembly clockwise until fixture seats tightly against the wall.
5. Make wiring connections. For multi-tap ballast, follow instructions below. Push wires back through the oblong opening in the back housing, into the outlet box. (Figure 4)

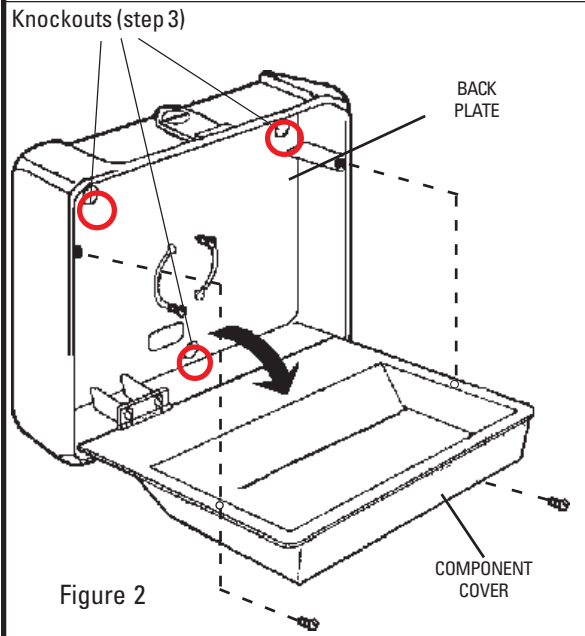

6. Reverse step 2: Raise hinged component cover and tighten screws.
7. Remove lamp from package and install per lamp installation instructions below.
8. Reverse step 1: Reinstall the front cover by tightening lens screws. (Optional Tamper Resistant Torx . screws are provided. For installation, remove existing door closure screws and insert the optional screws. These fasteners require a Torx T20 with center pin reject driver or bit to install and remove.

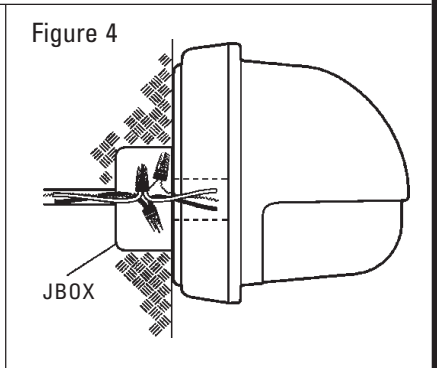
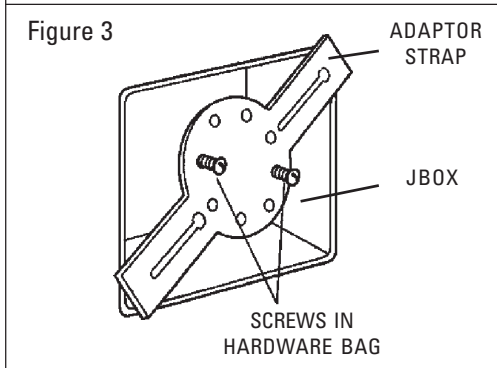

**Lamp Installation:** Loosen the 2 closing screws, hinge door assembly forward to access lamp compartment . Verify that the lamp source and wattage corresponds with the fixture and ballast label. HID -Screw the lamp securely into the socket, back it out one or two turns, and tighten securely again. This procedure properly seats the lamp in the socket. Close door using the standard closing screws. Compact Fluorescent: Push lamp into socket until the socket retention clips snap secure (you will hear a click).

**Multi-tap Ballast (TB):** The multi-tap ballast will be prewired for 277V at the factory. First determine the correct line voltage. Then select the corresponding fixture voltage lead, remove the crimped cap and connect to the supply voltage lead. The fixture lead marked COM should be connected to the neutral supply lead for 120 or 277. For 208 or 240, connect the other incoming hot leg to the fixture lead marked "COM". Be sure to cap off all unused fixture leads individually.

**Troubleshooting:** If this fixture fails to operate properly, check to make sure: The proper lamp is installed correctly. • The fixture is wired correctly. • The lamp is not faulty. • The fixture is grounded correctly. • The line voltage at the fixture is correct.