





**READ AND FOLLOW ALL SAFETY INSTRUCTIONS!
SAVE THESE INSTRUCTIONS AND DELIVER TO OWNER AFTER INSTALLATION**

- To reduce the risk of death, personal injury or property damage from fire, electric shock, falling parts, cuts/abrasions, and other hazards please read all warnings and instructions included with and on the fixture box and all fixture labels.
- Before installing, servicing, or performing routine maintenance upon this equipment, follow these general precautions.
- Installation and service of luminaires should be performed by a qualified licensed electrician.
- Maintenance of the luminaires should be performed by person(s) familiar with the luminaires' construction and operation and any hazards involved. Regular fixture maintenance programs are recommended.
- It will occasionally be necessary to clean the outside of the refractor/lens. Frequency of cleaning will depend on ambient dirt level and minimum light output which is acceptable to user. Refractor/lens should be washed in a solution of warm water and any mild, non-abrasive household detergent, rinsed with clean water and wiped dry. Should optical assembly become dirty on the inside, wipe refractor/lens and clean in above manner, replacing damaged gaskets as necessary.
- **DO NOT INSTALL DAMAGED PRODUCT!** This luminaire has been properly packed so that no parts should have been damaged during transit. Inspect to confirm. Any part damaged or broken during or after assembly should be replaced.
- These instructions do not purport to cover all details or variations in equipment nor to provide every possible contingency to meet in connection with installation, operation, or maintenance. Should further information be desired or should particular problems arise which are not covered sufficiently for the purchaser's or owner's purposes, this matter should be referred to Acuity Brands Lighting, Inc.

<div style="display: flex; align-items: center; margin-bottom: 10px;">  <div style="border: 1px solid black; padding: 5px; text-align: center;"> <p>WARNING RISK OF ELECTRIC SHOCK</p> </div> </div> <ul style="list-style-type: none"> ✓ Disconnect or turn off power before installation or servicing. ✓ Verify that supply voltage is correct by comparing it with the luminaire label information. ✓ Make all electrical and grounded connections in accordance with the National Electrical Code (NEC) and any applicable local code requirements. ✓ All wiring connections should be capped with UL approved recognized wire connectors. 	<div style="display: flex; align-items: center; margin-bottom: 10px;">  <div style="border: 1px solid black; padding: 5px; text-align: center;"> <p>WARNING RISK OF BURN</p> </div> </div> <ul style="list-style-type: none"> ✓ Allow lamp/fixture to cool before handling. Do not touch enclosure or light source. ✓ Do not exceed maximum wattage marked on luminaire label. ✓ Follow all manufacturer's warnings, recommendations and restrictions for: driver type, burning position, mounting locations/methods, replacement and recycling.
<div style="display: flex; align-items: center; margin-bottom: 10px;">  <div style="border: 1px solid black; padding: 5px; text-align: center;"> <p>CAUTION RISK OF INJURY</p> </div> </div> <ul style="list-style-type: none"> ✓ Wear gloves and safety glasses at all times when removing luminaire from carton, installing, servicing or performing maintenance. ✓ Avoid direct eye exposure to the light source while it is on. 	<div style="display: flex; align-items: center; margin-bottom: 10px;">  <div style="border: 1px solid black; padding: 5px; text-align: center;"> <p>CAUTION RISK OF FIRE</p> </div> </div> <ul style="list-style-type: none"> ✓ Keep combustible and other materials that can burn, away from lamp/lens. ✓ Do not operate in close proximity to persons, combustible materials or substances affected by heat or drying.



CAUTION: RISK OF PRODUCT DAMAGE

- ✓ Never connect components under load.
- ✓ Do not mount or support these fixtures in a manner that can cut the outer jacket or damage wire insulation.
- ✓ Controls for dimming, auto-sensing, or remote control of a luminaire that are not factory-wired to the luminaire must be checked for compatibility with the luminaire prior to installation. Never connect an LED product directly to a dimmer pack that has not been pre-approved. LED fixtures must be powered directly off a switched circuit.
- ✓ Unless individual product specifications deem otherwise: Do not restrict fixture ventilation. Allow for some volume of airspace around fixture. Avoid covering LED fixtures with insulation, foam, or other material that will prevent convection or conduction cooling.
- ✓ Unless individual product specifications deem otherwise: Do not exceed fixtures maximum ambient temperature.
- ✓ Only use fixture in its intended location.
- ✓ LED products are Polarity Sensitive. Ensure proper Polarity before installation.
- ✓ Electrostatic Discharge (ESD): ESD can damage LED fixtures. Personal grounding equipment must be worn during all installation or servicing of the unit.
- ✓ Do not touch individual electrical components as this can cause ESD, shorten lamp life, or alter performance.
- ✓ Some components inside the fixture may not be serviceable. In the unlikely event your unit may require service, stop using the unit immediately and contact an ABL representative for assistance.
- ✓ Always read the fixtures complete installation instructions prior to installation for any additional fixture specific warnings.

Please see product specific installation instructions for additional warnings or any applicable FCC or other regulatory statements.

Failure to follow any of these instructions could void product warranties.

Installation Instructions TWP-LED

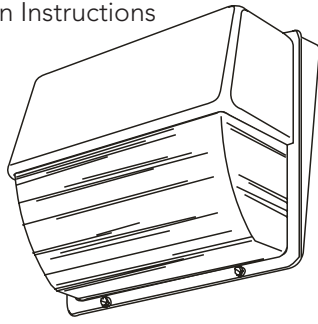

DELIVERY: Upon receipt of fixture and accessories (packed separately), thoroughly inspect for any freight damage. All damage should be reported to the delivery carrier. Compare the catalog description listed on the packing slip with the fixture label on the inside of the housing to be sure you have received the correct merchandise.

This device complies with Part 15 of the FCC Rules. Operation is subject to the following two conditions: (1) this device may not cause harmful interference, and (2) this device must accept any interference received, including interference that may cause undesired operation.

5 year limited warranty

Outlet box mounting:

1. Loosen the 2 captive screws in the front housing and remove front cover from fixture.
2. Remove electrical splice compartment cover. Keep (2) 8-32 screws for reinstallation.
3. Remove center knock out and feed wires through.
4. Mount fixture using dimensions shown in Figure A.
- 4a. If provided with an ALO device, adjust the dial to the required lumen level (use ALO table as reference), by turning it using a small flat head screwdriver.
5. Make supply connections. Reinstall the (2) 8-32 screws and electrical splice component cover removed in step 2, making sure no wires are pinched.
6. Replace front cover.
7. Tighten the 2 captive screws (30-35in lbs). Do not over tighten. Over tightening will cause stripping and void all warranties.

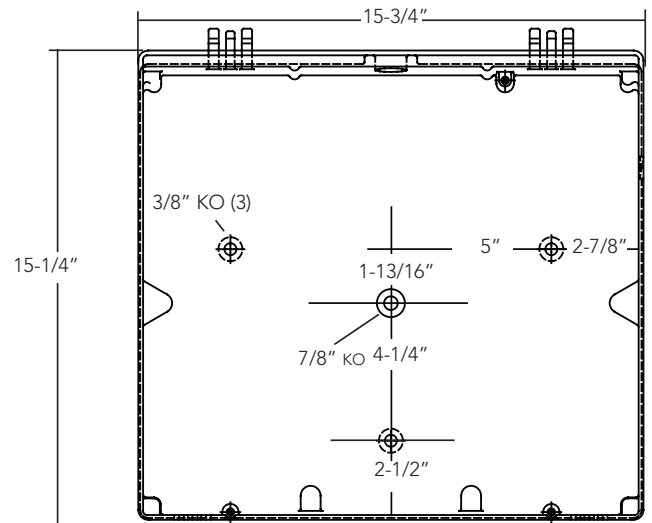
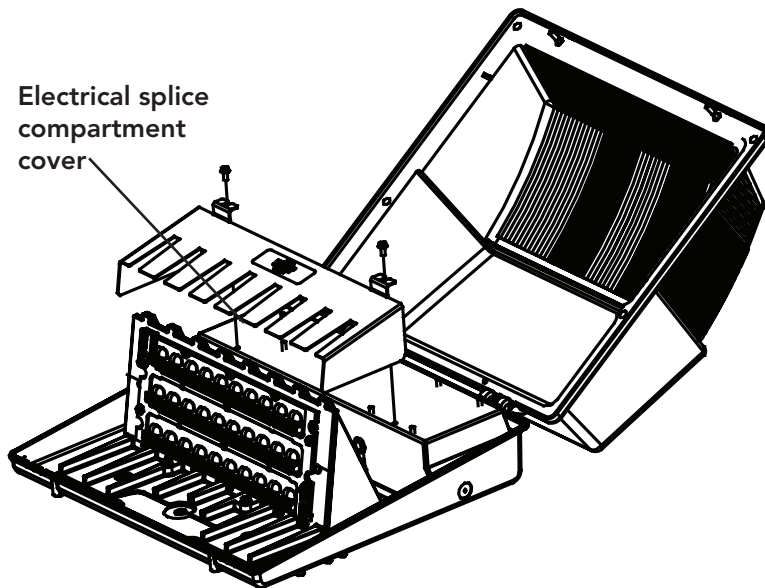

Conduit Tee mounting:

1. Loosen the 2 captive screws in the front housing and remove front cover from fixture.
2. Remove electrical splice compartment cover and driver cover. Keep (2) 8-32 and (2) 10-24 screws for reinstallation.
3. Remove top conduit cover disc.
4. Mount fixture using dimensions shown in Figure A. Thread conduit into fixture.
5. Make supply connections. Reinstall both compartment cover and driver cover using (2) 8-32 and (2) 10-24 screws removed in step 2, making sure no wires are pinched.
6. Replace front cover.
7. Tighten the 2 captive screws. Do not over tighten. Over tightening will cause stripping and void all warranties.

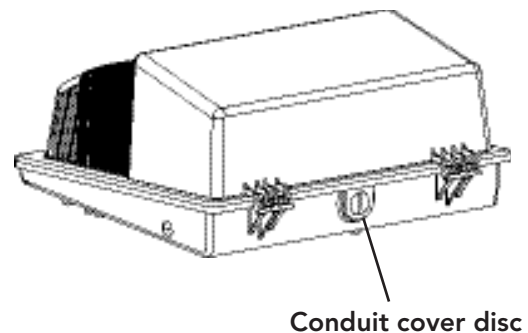

Installation Instructions
TWP-LED

Wire Guard

WALL MOUNT:

1. Drill wall in two places for two (2) 10-24 fasteners (not provided) per drilling detail (Figure D).
2. Place wire guard over fixture.
3. Secure in place with fasteners from step 1.

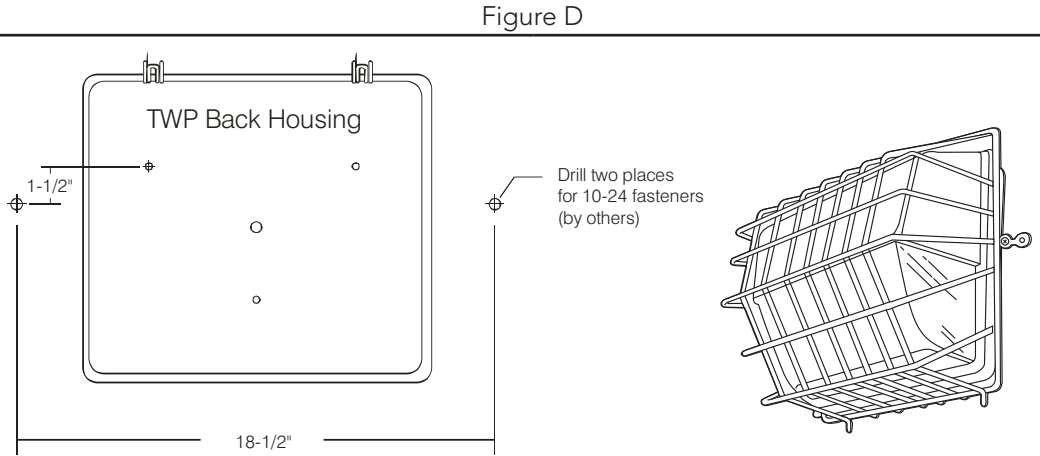

FIXTURE MOUNT:

1. Drill fixture per drilling detail (Figure E). NOTE: Remove photoelectric cell (when provided) before drilling for fixture mounted wire guard.
2. Place wire guard over fixture.
3. Secure in place with two (2) 10-24 fasteners, washers, and spacers (provided) as shown (Figure F).

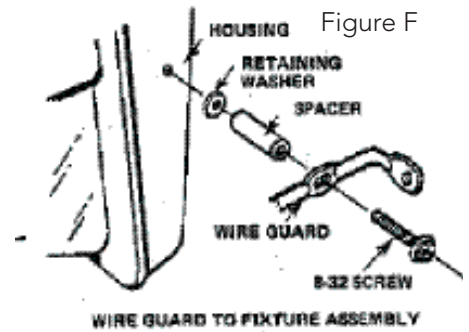
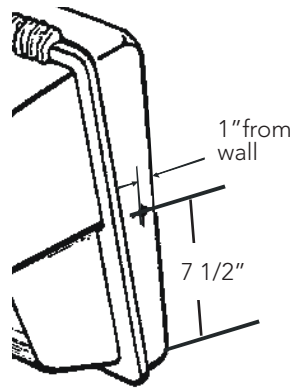

Troubleshooting: If this fixture fails to operate properly, check to make sure: • The fixture is wired correctly. • The fixture is grounded correctly. • The line voltage at the fixture is correct. If all these variables have been checked and the fixture still does not operate as specified, contact your local Lithonia Lighting distributor.