



**READ AND FOLLOW ALL SAFETY INSTRUCTIONS!
SAVE THESE INSTRUCTIONS AND DELIVER TO OWNER AFTER INSTALLATION**

- To reduce the risk of death, personal injury or property damage from fire, electric shock, falling parts, cuts/abrasions, and other hazards please read all warnings and instructions included with and on the fixture box and all fixture labels.
- Before installing, servicing, or performing routine maintenance upon this equipment, follow these general precautions.
- Installation and service of luminaires should be performed by a **qualified licensed electrician**.
- Maintenance of the luminaires should be performed by person(s) familiar with the luminaires' construction and operation and any hazards involved. Regular fixture maintenance programs are recommended.
- It will occasionally be necessary to clean the outside of the refractor/lens. Frequency of cleaning will depend on ambient dirt level and minimum light output which is acceptable to user. Refractor/lens should be washed in a solution of warm water and any mild, non-abrasive household detergent, rinsed with clean water and wiped dry. Should optical assembly become dirty on the inside, wipe refractor/lens and clean in above manner, replacing damaged gaskets as necessary.
- **DO NOT INSTALL DAMAGED PRODUCT!** This luminaire has been properly packed so that no parts should have been damaged during transit. Inspect to confirm. Any part damaged or broken during or after assembly should be replaced.
- Recycle: For information on how to recycle LED electronic products, please visit www.epa.gov.
- These instructions do not purport to cover all details or variations in equipment nor to provide every possible contingency to meet in connection with installation, operation, or maintenance. Should further information be desired or should particular problems arise which are not covered sufficiently for the purchaser's or owner's purposes, this matter should be referred to Acuity Brands Lighting, Inc.



WARNING
RISK OF ELECTRIC SHOCK

- ✓ Disconnect or turn off power before installation or servicing.
- ✓ Verify that supply voltage is correct by comparing it with the luminaire label information.
- ✓ Make all electrical and grounded connections in accordance with the National Electrical Code (NEC) and any applicable local code requirements.
- ✓ All wiring connections should be capped with UL approved recognized wire connectors.



WARNING
RISK OF BURN

- ✓ Allow lamp/fixture to cool before handling. Do not touch enclosure or light source.
- ✓ Do not exceed maximum wattage marked on luminaire label.
- ✓ Follow all manufacturer's warnings, recommendations and restrictions for: driver type, burning position, mounting locations/methods, replacement and recycling.



CAUTION
RISK OF INJURY

- ✓ Wear gloves and safety glasses at all times when removing luminaire from carton, installing, servicing or performing maintenance.
- ✓ Avoid direct eye exposure to the light source while it is on.



CAUTION
RISK OF FIRE

- ✓ Keep combustible and other materials that can burn, away from lamp/lens.
- ✓ Do not operate in close proximity to persons, combustible materials or substances affected by heat or drying.



CAUTION: RISK OF PRODUCT DAMAGE

- ✓ Never connect components under load.
- ✓ Do not mount or support these fixtures in a manner that can cut the outer jacket or damage wire insulation.
- ✓ Unless individual product specifications deem otherwise: Never connect an LED product directly to a dimmer packs, occupancy sensors, timing devices, or other related control devices. LED fixtures must be powered directly off a switched circuit.
- ✓ Unless individual product specifications deem otherwise: Do not restrict fixture ventilation. Allow for some volume of airspace around fixture. Avoid covering LED fixtures with insulation, foam, or other material that will prevent convection or conduction cooling.
- ✓ Unless individual product specifications deem otherwise: Do not exceed fixtures maximum ambient temperature.
- ✓ Only use fixture in its intended location.
- ✓ LED products are Polarity Sensitive. Ensure proper Polarity before installation.
- ✓ Electrostatic Discharge (ESD): ESD can damage LED fixtures. Personal grounding equipment must be worn during all installation or servicing of the unit.
- ✓ Do not touch individual electrical components as this can cause ESD, shorten lamp life, or alter performance.
- ✓ Some components inside the fixture may not be serviceable. In the unlikely event your unit may require service, stop using the unit immediately and contact an ABL representative for assistance.
- ✓ Always read the fixtures complete installation instructions prior to installation for any additional fixture specific warnings.

Please see product specific installation instructions for additional warnings or any applicable FCC or other regulatory statements.

Failure to follow any of these instructions could void product warranties.

Our Brands	Indoor/Outdoor Lithonia Lighting Carandini HoloPhane RELOC Light Concepts	Indoor Lighting Gotham Mark Architectural Lighting Peerless Renaissance Lighting Winona Lighting	Outdoor Lighting American Electric Lighting Antique Street Lamps Hydrel Tersen	Controls DARK TO LIGHT LC&D ROAM Sensor Switch Synergy	Daylighting SunOptics
------------	--	---	--	---	--------------------------

Acuity Brands Lighting, Inc. assumes no responsibility for claims arising out of improper or careless installation or handling of its products.

ABL LED General Warnings, Form No. 503.203

IBG LED HIGHBAY

INSTALLATION INSTRUCTIONS

WARNING: Please read all “important safety instructions” prior to installation of this product.

A) Identification of IBG Luminaire – Page 4

- 1) IBG 12000LM, 15000LM
- 2) IBG 18000LM, 24000LM
- 3) BPK Option
- 4) PS30250 Option
- 5) WGX Option
- 6) IBG V-HANGER Accessory
- 7) THUN (Surface Mount) Accessory
- 8) PMP (Pendant Mount) Option

B) Required Handling Locations – Page 5

C) Pre-installation for all mounting – Page 5

D) Installation – Suspended Fixture – Page 5

E) Installation – THUN (Surface) Mount – Page 6

F) Installation – PMP (Pendant) Mount – Page 6

G) Wiring – IMP Connector – Page 7

H) Servicing – Page 7

SECTION A: Identification of IBG Luminaire

IBG 12000LM, 15000LM

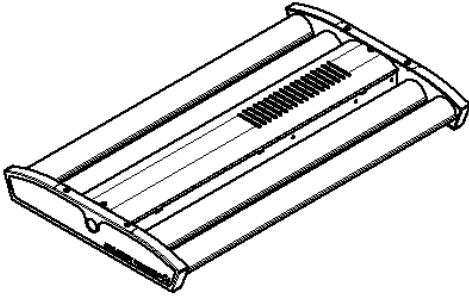

IBG 18000LM, 24000LM

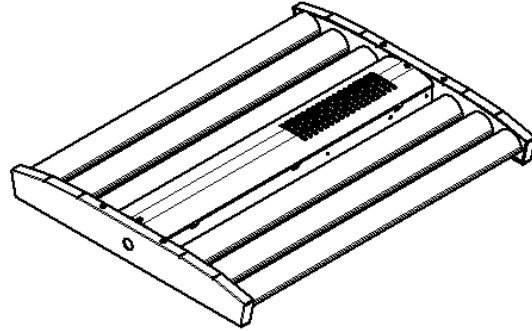

BPK OPTION (Access Plate not removable)

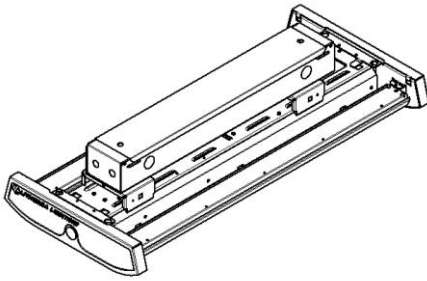

PS30250 OPTION (Access Plate not removable)

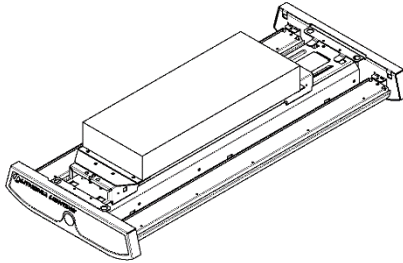

WGX OPTION

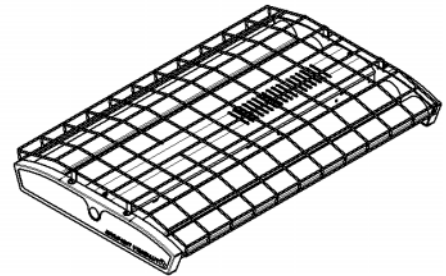

HBBS V-HANGER ACCESSORY

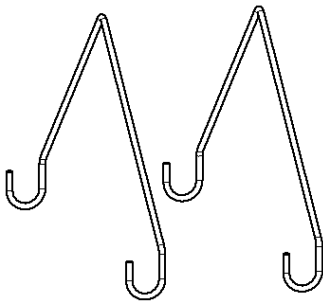

THUN ACCESSORY

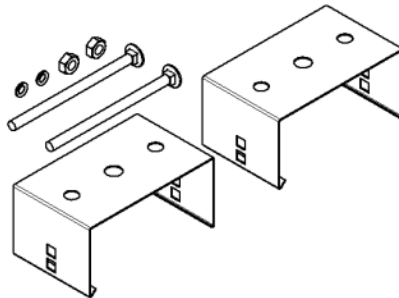

IBG PMP ACCESSORY

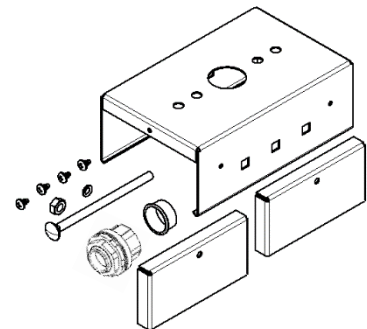

SECTION B: REQUIRED HANDLING LOCATIONS

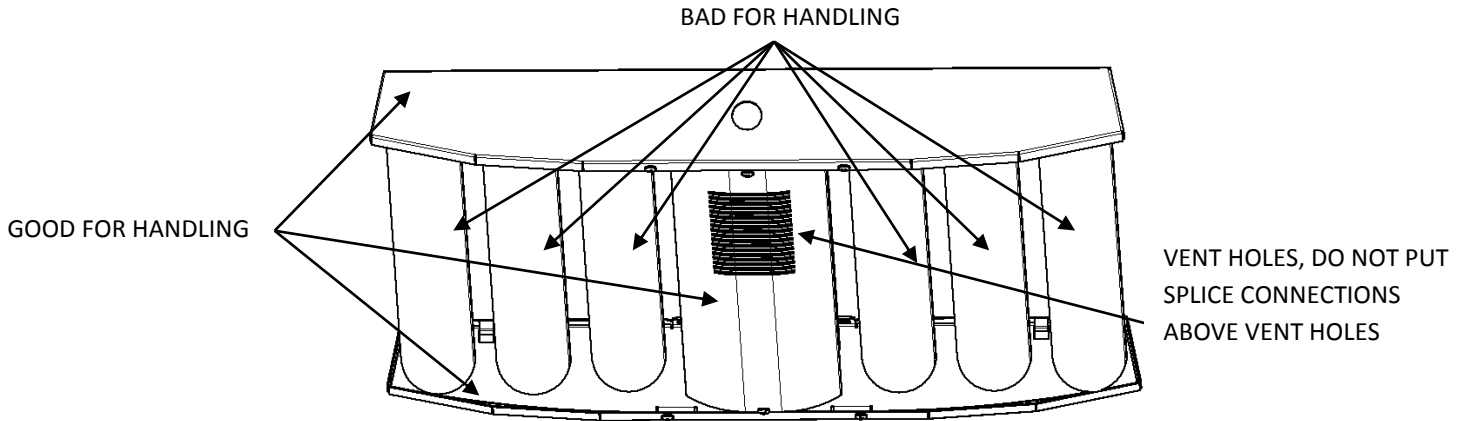

When handling the fixture during unpacking and installation do NOT use LED Modules for carrying/support. DO use the center channel and end caps for carrying/support

Section C: PRE-INSTALLATION FOR ALL MOUNTING

- 1) Ensure power is OFF.
- 2) Inspect the mounting location for damage before installing new IBG Luminaire. Ensure mounting structure is properly sized to support the weight of the fixture.
- 3) BPK and PS30250 are not available with THUN (Surface) or PMP (Pendant) mounting.
- 4) Remove luminaire from packing and inspect for any damages. If the fixture is damaged do not use; call your local representative for assistance.
- 5) If a protective wrapping is included, do not remove until the final building/inspection stage. Do not use this luminaire as a work light during construction. Do not touch the LEDs.
- 6) After installation ensure no wires are pinches or caught outside the electrical channel.

SECTION D: INSTALLATION - SUSPENDED FIXTURE

- 1) If using the V-hanger and chain, feed hanger through chain link.
- 2) If using the HBBS V-Hanger (supplied with HBBS36 and HBBSACVH), hook the hanger through holes in end cap shown below and crimp closed. If using aircraft cable and hook, use the same holes to suspend the fixture. If using the HC V-Hanger (supplied with HC36 and ZACVH), hook the hanger through holes in the electrical channel shown below. **WARNING:** For GYM applications additional safety cables are needed.

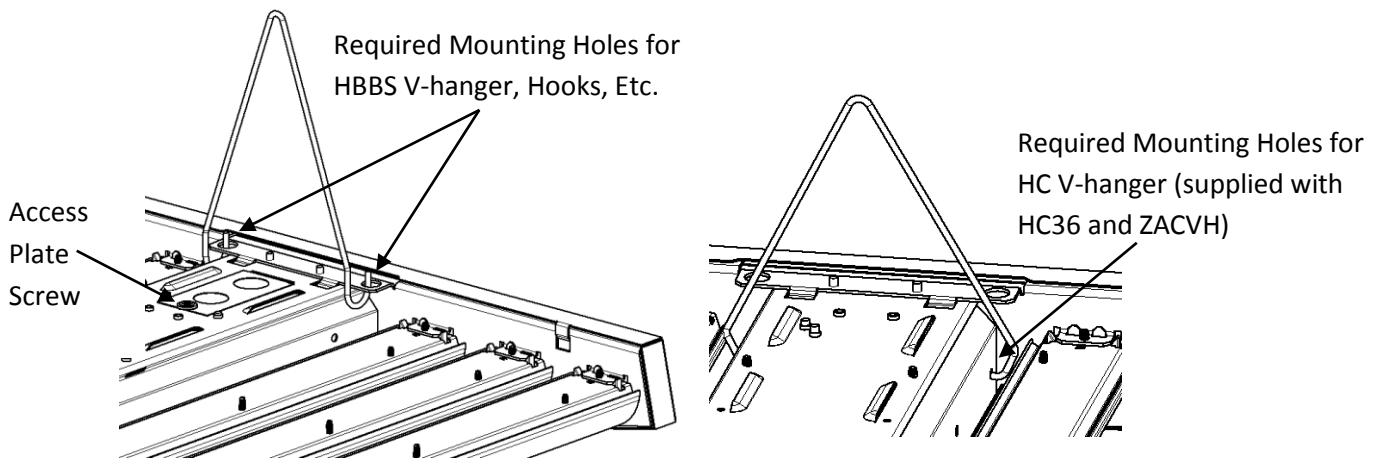

- 3) Remove access plate screw as shown above. Input wires will be attached to the access plate. Remove the necessary knockout(s) and connect input wires black to black, white to white and green to green. Use only UL listed connectors rated 90C or greater. Purple and Gray wires are low voltage dimming leads.
- 4) Make any necessary electrical connections. Supply wire must meet applicable electrical codes and be rated for a minimum of 90°C. Purple and gray leads are 0-10V (low voltage) dimming leads.
- 5) Push wires inside center channel, ensure electrical connections are not located above vent holes as shown in the Section B image. FAILURE TO DO SO WILL VOID CERTIFICATION AND WARRANTY.

SECTION E: INSTALLATION – THUN MOUNT

- 1) Follow Steps 3-5 from Section D
- 2) Attach THUN brackets to structure (not supplied). Two THUN brackets MUST be used on all configurations.
- 3) Support fixture while snapping fixture into THUN brackets. Ensure fixture is balanced.
- 4) Use supplied hardware to tighten THUN brackets around center channel as shown below. Tighten bolts to 13 in/lbs.

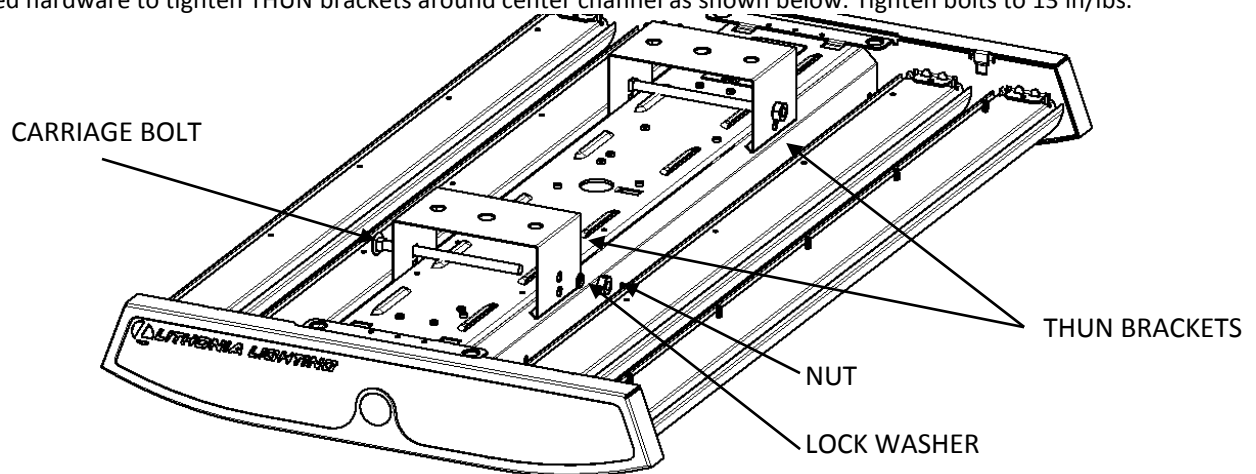

SECTION F: INSTALLATION – PMP MOUNT

- 1) PMP Mounting is not available with BPK or PS30250
- 2) Attach PMP Hub to threaded pendant/conduit (not supplied) using 3/4" - 14 NPT THREAD HUB and Nut (supplied) as shown below.
- 3) If luminaire is 2FT install plastic bushing (supplied) in center hole.
- 4) Support fixture while snapping fixture into PMP Bracket. PMP bracket may need to be shifted off center in order for the fixture to remain balanced. Ensure PMP Bracket Teeth fit inside center channel as shown below.

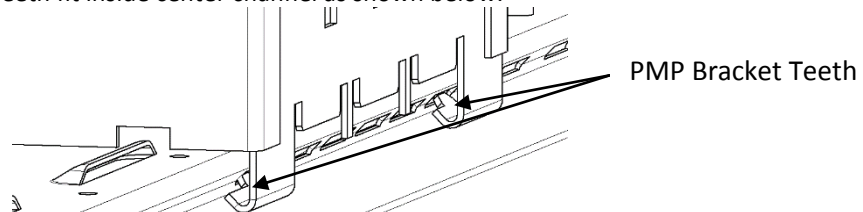

- 5) Use supplied carriage bolt, washer, and nut to tighten PMP Hub around center channel. Tighten to 13 in/lbs
- 6) Input wires will be pulled out of the center of the fixture. Make any necessary electrical connections. Supply wire must meet applicable electrical codes and be rated for a minimum of 90°C. Purple and gray leads are 0-10V (low voltage) dimming leads.
- 7) Attach PMP Bracket sides with screws, one each as shown below. Ensure wires are not pinched.
- 8) DO NOT LEAN ON FIXTURE ONCE PMP IS ATTACHED.

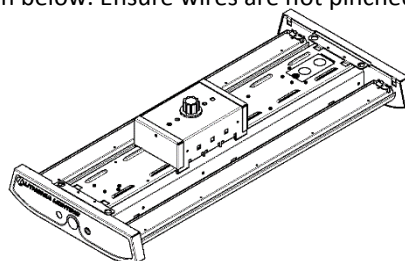
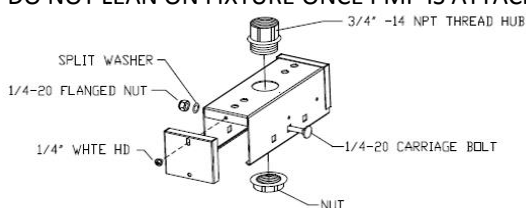

Section J: Wiring – IMP Connector

- 1) Install fixture based on specified mounting instructions.
- 2) A 5/8" knock out is located on the IMP access plate. If dimming is required remove access plate and knock out knockout. Pull dimming wires through access plate and connect to dimming circuit. Reattached access plate to fixture.
- 3) Snap supply power with IMP male connector (not supplied) into luminaire female IMP connector.

SECTION K: SERVICING

- 1) Clean fixture as needed. Double check all mounting hardware.
- 2) After installation, wear protective gloves if the lenses need to be removed
- 3) The lens snaps around LED channel. To remove lens, carefully pull on outer leg to disengage from LED channel. Continue pulling outer leg along the fixture length to disengage lens.
- 4) To replace the lens snap around LED Channel as shown in the image below.

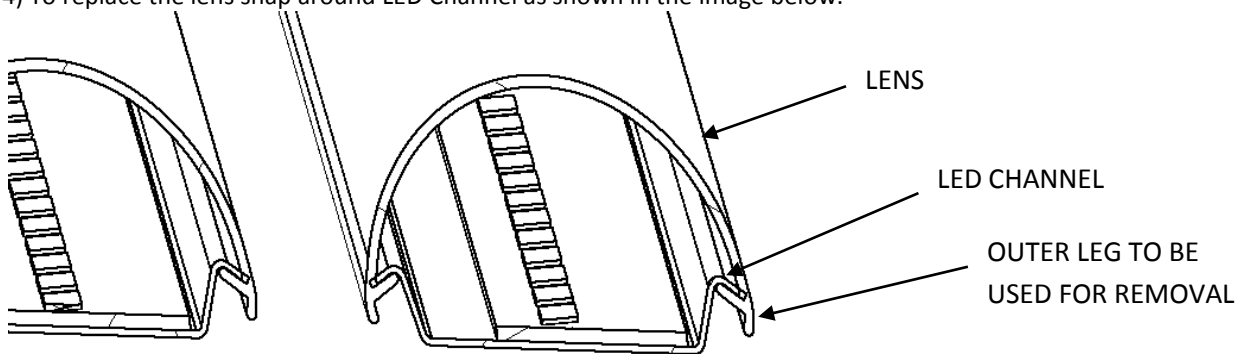

- 5) To access electrical components, loosen the two captive screws from central channel cover as shown below.
- 6) Driver Channel Cover will hang on central channel during servicing. Be cautious to avoid bumping fixture as the driver channel cover can become disengaged.

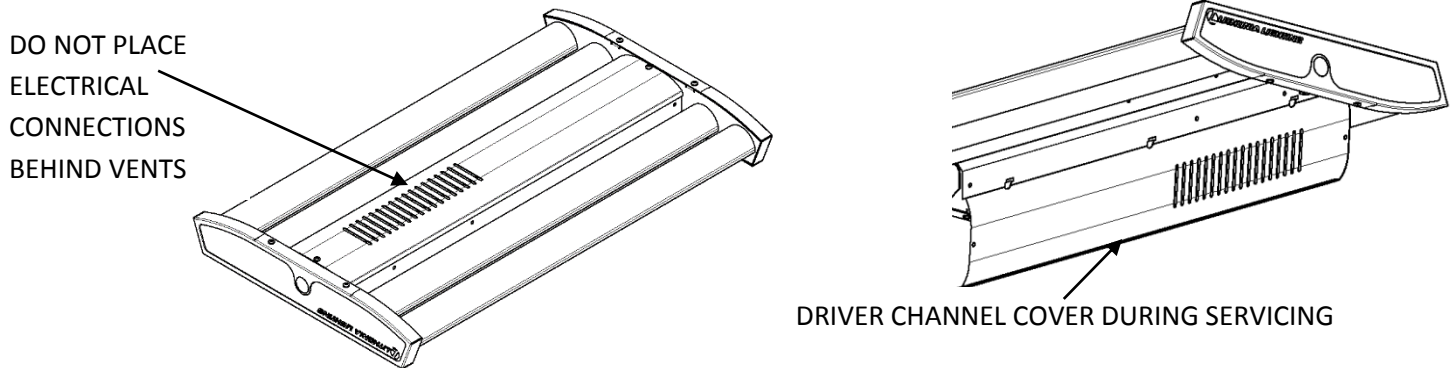

- 7) Make any necessary adjustments or driver changes. DO NOT PLACE ELECTRICAL CONNECTIONS ABOVE DRIVER CHANNEL COVER VENTS
- 8) Close Driver channel cover and secure using two screws.