

# 50mm (2") LED Track Light - 120VAC

**SORAA arc™**

The Soraa Arc™ Track light combines elegant design with Soraa's unique quality of light to create a dynamic and versatile solution for retail, hospitality, and residential applications. Soraa Arc gets its name from its unique die-cast curved heat sink, which features a form carefully engineered for optimal thermal performance. Soraa Arc is compatible with Soraa SNAP™, which allows you to shape beams, shift color, and more - in a snap.

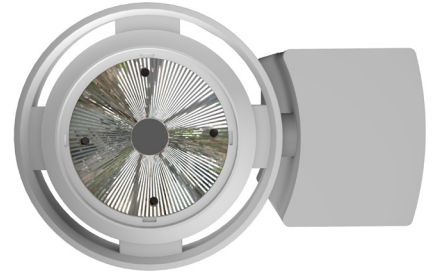
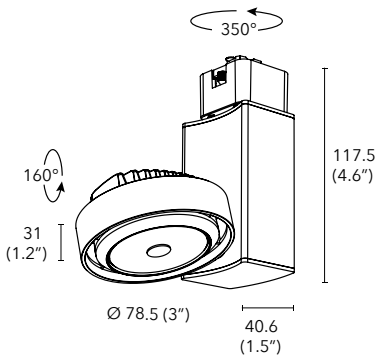

## Soraa VIVID™ LED

Soraa Full Spectrum integral LED Light Engine available in 2700K, 3000K, and 4000K with 95 CRI and 95 R9. IR and UV free.

## Soraa Optics

Soraa optic technology with exceptional beam control and smooth uniform light distribution. The 10° and 15° beam versions are compatible with Soraa SNAP accessories.

## Construction and Finish

Light engine is made of die cast aluminium, transformer case from extruded aluminium. Durable satin finish. Custom colors available. Tilt: 160°, rotation: 350°.

## Electrical

120VAC fully integral LED electronic constant current driver (included).  
Frequency: 50/60Hz  
Power Factor: 0.93  
Wattage: 11,18

## Dimming and Flicker

Dimmable to <1%  
Percent Flicker: < 30%  
Triac and ELV dimming standard  
Visit [www.soraa.com](http://www.soraa.com) for details

## Operating Temperature

Minimum -40°C, 25°C typical.

## Applications

Suitable for damp or dry locations. For interior use only.

## Accessories

Luminaire accommodates both Arc accessories and Soraa SNAP simultaneously.

## Compliance

cULus Listed. FCC CFR Title 47 Part 15 Class B compliant. NOM compliant.

## Warranty

Five year warranty. .



## Build Your Luminaire Sample Number: ART50-25D-927-U-L-W

Series	Beam & Wattage	CCT	Driver	Track Compatibility	Finish	Region
<b>ART50</b> Soraa Arc Track, 50mm	<b>10D</b> 10° Narrow Spot - 11W ☺ <b>15D</b> 15° Narrow Spot - 18W ☺ <b>25D</b> 25° Narrow Flood - 18W <b>36D</b> 36° Flood - 18W	<b>927</b> 2700K <b>930</b> 3000K <b>940</b> 4000K	<b>U</b> 120VAC Triac & ELV	<b>H</b> H style -120VAC <b>J</b> J style - 120VAC <b>L</b> L style - 120VAC (other adapters available)	<b>B</b> Black <b>W</b> White <b>S</b> Silver <b>C</b> Custom	<b>US</b> , Canada <b>S7</b> Mexico

# Photometrics - Soraa Arc™ 50mm (2")

Data is shown for 3000K, for 2700K multiply FC by 0.95, for 4000K by 1.04.

## Narrow Spot 10°

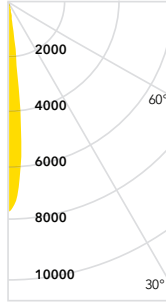

W	CCT	Lm	CBCP
11	2700	505	7360 cd
11	3000	535	7800 cd
11	4000	555	8090 cd

### Candelas at Nadir

0°	8139
5°	5415
15°	248
25°	91
35°	54
45°	25



Soraa SNAP  
Compatible

## Spot 15°

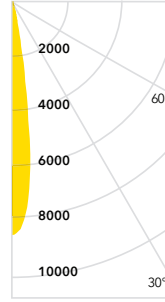

W	CCT	Lm	CBCP
18	2700	880	7650 cd
18	3000	930	8080 cd
18	4000	965	8380 cd

### Candelas at Nadir

0°	8165
5°	6573
15°	628
25°	151
35°	87
45°	46



Soraa SNAP  
Compatible

## Narrow Flood 25°

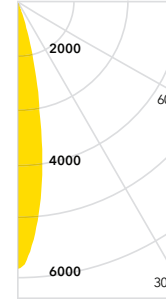

W	CCT	Lm	CBCP
18	2700	950	5510 cd
18	3000	1000	5800 cd
18	4000	1040	6030 cd

### Candelas at Nadir

0°	5870
5°	4970
15°	1562
25°	128
35°	37
45°	25

## Flood 36°

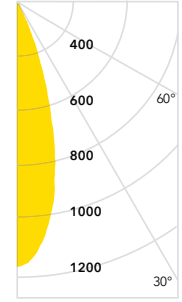

W	CCT	Lm	CBCP
18	2700	950	2560 cd
18	3000	1000	2700 cd
18	4000	1040	2800 cd

### Candelas at Nadir

0°	2771
5°	2683
15°	1627
25°	408
35°	82
45°	32

## Aiming Angles

L and W refer to outer points where footcandles drop to 50% of maximum. FC refers to initial footcandles at the center of the beam.

Key  
**L** Beam Distance    **FC** Footcandles  
**D** Distance        **C** Distance to Center Beam  
**W** Beam Width

### 0° Horizontal

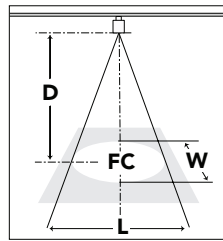

### 30° Horizontal

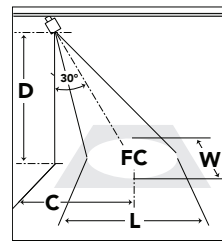

### 30° Vertical

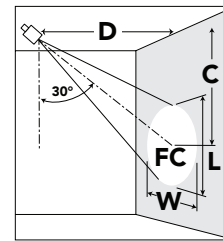

### 60° Vertical

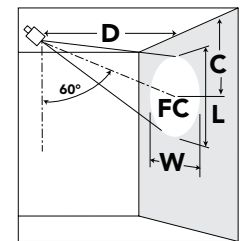

### Narrow Spot 10° (11W)

D	FC	L	W
6	223	1.3	1.2
8	127	1.7	1.7
10	82	2.1	2.1
12	58	2.5	2.5

D	C	FC	L	W
6	3.7	148	1.6	1.4
8	4.8	85	2.2	1.9
10	5.9	54	2.7	2.3
12	6.9	39	3.2	2.8

D	C	FC	L	W
2	3.7	287	1.4	0.7
3	5.4	130	2.1	1.0
4	7.0	75	2.7	1.4
5	8.6	48	3.4	1.7

D	C	FC	L	W
2	1.4	1226	0.6	0.5
3	2.0	580	0.8	0.7
4	2.6	330	1.1	1.0
5	3.2	212	1.4	1.2

### Spot 15°

6	226	1.6	1.6
8	127	2.1	2.1
10	82	2.6	2.6
12	57	3.1	3.1

6	3.7	151	2.1	1.8
8	4.8	86	2.8	2.3
10	5.9	55	3.4	2.9
12	7.0	39	4.1	3.5

2	3.7	307	1.7	0.9
3	5.4	140	2.5	1.3
4	7.1	79	3.3	1.8
5	8.7	51	4.1	2.1

2	1.4	1274	0.7	0.6
3	2.1	591	1.0	0.9
4	2.7	335	1.4	1.2
5	3.3	216	1.7	1.5

### Narrow Flood 25°

6	164	2.2	2.2
8	93	2.9	2.9
10	61	3.6	3.6
12	43	4.3	4.3

6	3.6	109	2.9	2.5
8	4.8	62	3.8	3.3
10	6.0	41	4.6	4.1
12	7.1	28	5.5	4.9

2	3.9	239	2.1	1.2
3	5.7	108	3.1	1.8
4	7.5	62	4.1	2.4
5	9.3	40	5.1	2.9

2	1.3	943	1.0	0.9
3	1.9	429	1.4	1.3
4	2.5	244	1.9	1.7
5	3.1	156	2.4	2.1

### Flood 36°

6	78	3.3	3.2
8	45	4.3	4.2
10	29	5.3	5.3
12	21	6.2	6.2

6	3.8	57	3.8	3.5
8	5.0	32	5.0	4.6
10	6.1	21	6.2	5.5
12	7.1	15	7.5	6.6

2	4.2	152	2.1	1.5
3	6.0	68	3.2	2.2
4	7.7	39	4.2	3.0
5	9.3	25	5.1	3.6

2	1.4	490	1.3	1.2
3	2.0	221	1.9	1.8
4	2.6	126	2.6	2.4
5	3.3	82	3.1	2.9

# Soraa Arc™ Color and Whiteness Rendering

CCT	CRI	R9	Rf	Rg	Rfh1	Rw	McA
2700	95	95	90	100	95	120	3
3000	95	95	90	100	95	120	3
4000	95	95	90	100	95	70	4

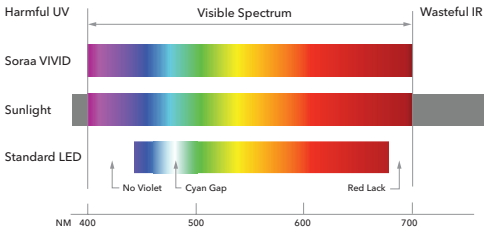

Soraa has engineered the perfect balance between color rendering and white rendering. Soraa's core technology uses a violet LED emitter as the basis for full spectrum light. This allows both Vivid™ color rendering and Natural White™ white rendering, which creates whiteness by exciting fluorescing agents with violet radiation, without the harmful effect of UV.

**Rf:** The TM-30 metric for color fidelity (similarity to colors under natural light), a more accurate version of the CRI Ra. Rf is 100 for natural light.

**Rg:** The TM-30 metric for color gamut (whether colors are more saturated than under natural light). Rg is 100 for natural light.

**Rfh1:** The TM-30 metric for color fidelity for red tones. Rfh1 is a more accurate version of the CRI R9. Rfh1 is 100 for natural light.

**Rw:** The Soraa-developed metric for white fidelity. Rw measures the magnitude of excitation of whitening agents within white materials. Rw is 100 for natural light.

2700K

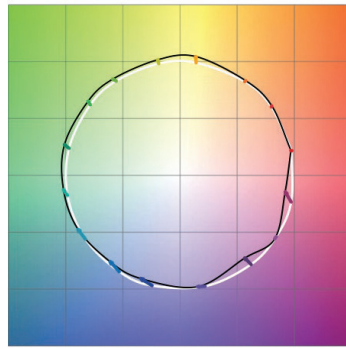

Rf: 90, Rg: 100, Rfh1: 95

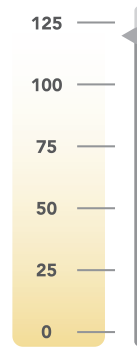

Rw: 120

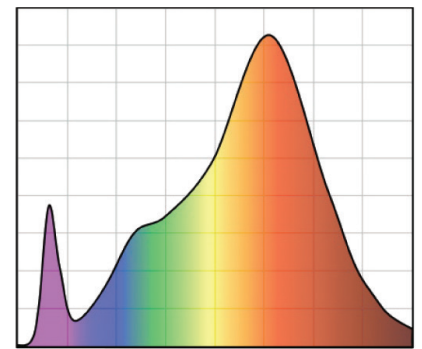

CRI: 95, R9: 95

3000K

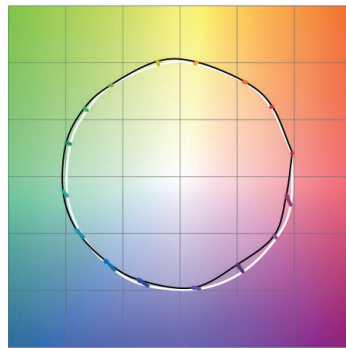

Rf: 90, Rg: 100, Rfh1: 95

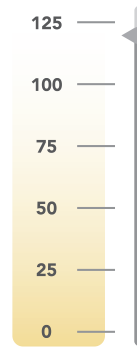

Rw: 120

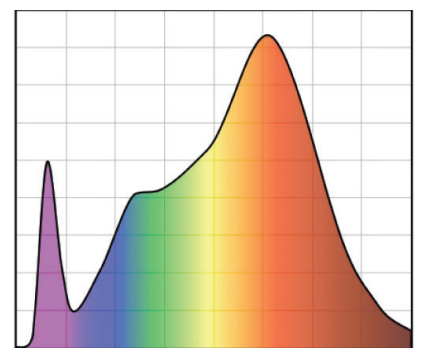

CRI: 95, R9: 95

4000K

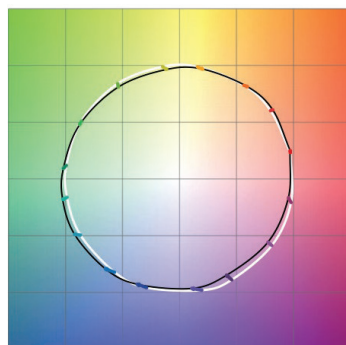

Rf: 90, Rg: 100, Rfh1: 95

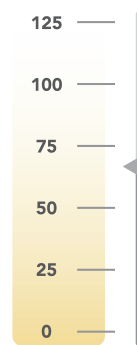

Rw: 70

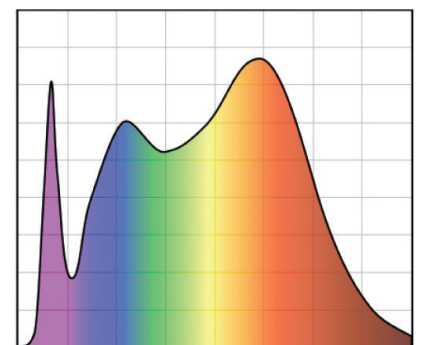

CRI: 95, R9: 95