

INSTALLATION INSTRUCTIONS FOR THE LLL SERIES FIXTURE

APPLICATION: General/Perimeter Lighting

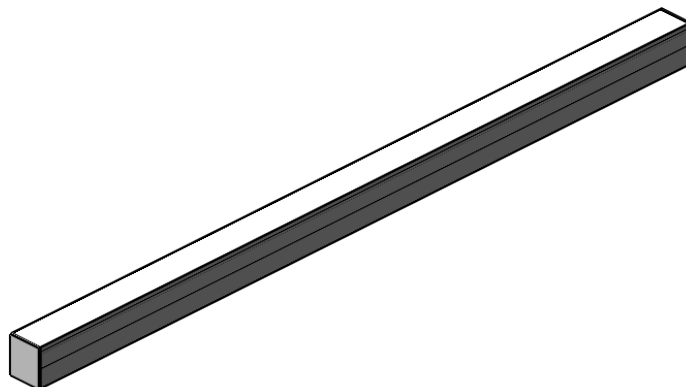

STOP! - READ THIS FIRST! - IMPORTANT SAFETY INSTRUCTIONS!

- For information on how to recycle LED/Fluorescent electronic products, please visit www.epa.gov.
- Do not install damaged product. This fixture is properly packed to prevent damage during transit.
- All wiring connections should be capped with UL approved recognized wire connectors.
- Do not touch LED diodes or any connecting clips; these parts are very sensitive.
- Do not exceed maximum wattage marked on fixture label.

Carefully read the instructions pertaining to your fixture thoroughly. IF YOU HAVE ANY QUESTIONS REGARDING THE PROPER INSTALLATION OR LOCAL CODES, CONSULT A QUALIFIED ELECTRICIAN.	Injury to persons and damage to the fixture and/or mounting surface may occur if the fixture is pulled from the surface. To reduce risk of injury or damage, mount only to a mechanically sound surface.
Both cord set and hard wired fixtures are intended for connection to a grounded, three-wire source of supply.	Install and wire the fixture in locations in accordance with all national, state and local codes.
Do not install outdoors or in applications other than intended use.	To avoid shock hazard, do not work with live electrical wires.
Ensure fixture is properly grounded before testing.	This fixture is intended for dry applications only.



WARNING: THIS PRODUCT MUST BE INSTALLED IN ACCORDANCE WITH THE APPLICABLE INSTALLATION CODE BY A PERSON FAMILIAR WITH THE CONSTRUCTIONS AND OPERATIONS OF THE PRODUCT AND THE HAZARDS INVOLVED.



WARNING: RISK OF FIRE; MINIMUM OF 90°C SUPPLY CONDUCTOR SHOULD BE USED. CONSULT A QUALIFIED ELECTRICIAN TO ENSURE CORRECT BRANCH CIRCUIT CONDUCTOR.



WARNING: TO AVOID ELECTRIC SHOCK HAZARD, DISCONNECT THE POWER AT THE PANEL BOARD (CIRCUIT BREAKER BOX) BEFORE BEGINNING INSTALLATION.



WARNING: TO AVOID FIRE HAZARD RISK, WHEN INSTALLING HARD WIRED UNITS, BE AWARE IF SUPPLY WIRES ARE LOCATED WITHIN THREE INCHES OF BALLAST. IF SO, USE WIRE RATED FOR AT LEAST 90°C (194°F). IF UNSURE, CONSULT A QUALIFIED ELECTRICIAN BEFORE INSTALLING.

PLEASE NOTE: SYSTEM CONTAINS BOTH MALE AND FEMALE WIRE HARNESSSES

1



REMINDER: TO AVOID ELECTRIC SHOCK HAZARD, DISCONNECT THE POWER AT THE PANEL BOARD (CIRCUIT BOX) BEFORE BEGINNING INSTALLATION!

2

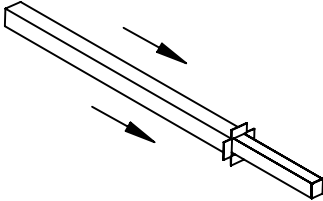

Carefully remove fixture from packaging. Use gloves to prevent dirt and oils from transferring to the unit. Inspect the fixture for any defects before proceeding.

3

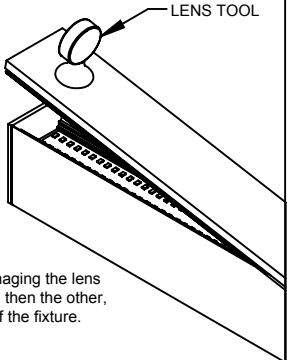

NOTE: Avoid damaging the lens by lifting one side, then the other, down the length of the fixture.

Using the Lens Tool provided, remove the lens by pressing the Lens Tool to the lens on one end, the pull back gently.

4

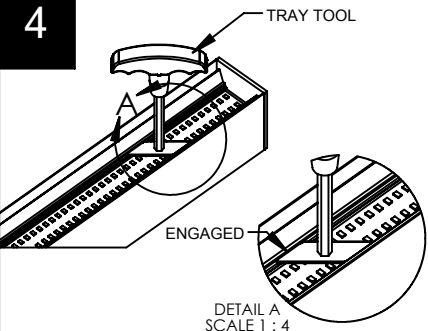

TRAY TOOL
ENGAGED
DETAIL A SCALE 1 : 4

Remove the tray from the fixture by inserting the Tray Tool on one end of the tray. Rotate the tool so that the edges engage the track of the tray as shown.

5

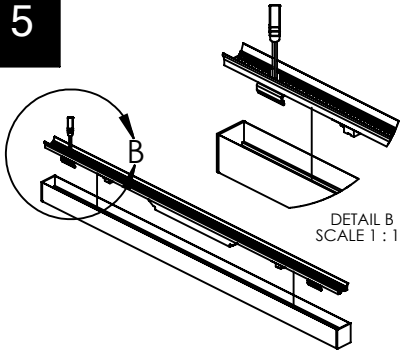

DETAIL B SCALE 1 : 11

Pull the tray straight up and out of the fixture. A moderate amount of force may be used. Lay the tray behind the fixture. Note the tray is connected by safety cables.

6

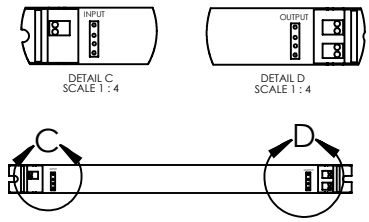

DETAIL C SCALE 1 : 4
DETAIL D SCALE 1 : 4

Note the directional flow of current. The driver is labeled as "Input" side and "Output" side. This is extremely important, especially for continuous run. See step 14 for details.

7

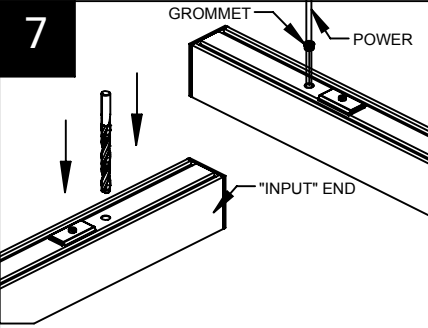

GROMMET
POWER
"INPUT" END

On the "Input" side of the fixture, drill a 3/8" hole center to the back of the fixture, approx 6" from the end. Install a 3/8" grommet. Feed the power wire thru the grommet, from inside the fixture - leading out.

8

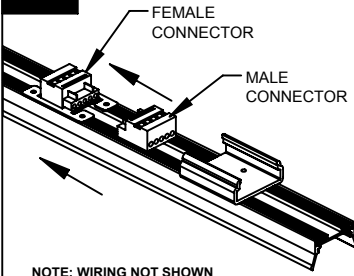

FEMALE CONNECTOR
MALE CONNECTOR

NOTE: WIRING NOT SHOWN FOR CLARITY

Plug the power supply in to the driver on the side marked "Input".

9

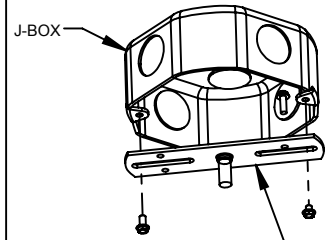

J-BOX
PENDANT MNT KIT

Install the Power feed Pendant Mnt Kit to the existing J-BOX. See HC401-PF instructions for details.

10

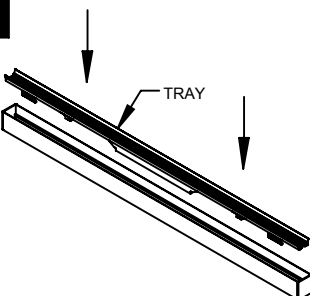

TRAY

Reinstall the tray to the fixture by lining it back up with the pan. Press downward until the pan snaps in to place, making an audible "click" sound.

11

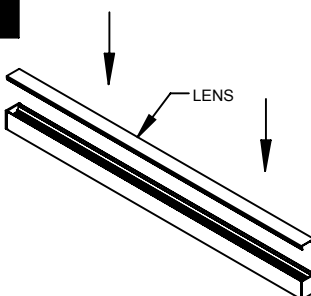

LENS

Reinstall the lens by lining it back up with the top of the fixture. Then, starting from one end and working towards the other, gently press the lens back down in to place.

12

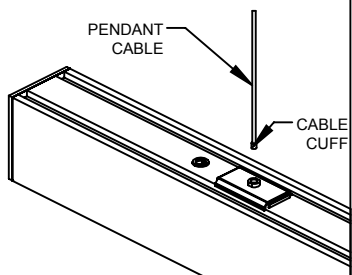

PENDANT CABLE
CABLE CUFF

Attach the Pendant Cable to the Pendant Clip on the back of the fixture by inserting the Cable Cuff and rotating clockwise until the Cuff locks in place.

PLEASE NOTE: SYSTEM CONTAINS BOTH MALE AND FEMALE WIRE HARNESES

