

INSTALLATION INSTRUCTIONS



STOP! - READ THIS FIRST! - IMPORTANT SAFETY INSTRUCTIONS!

- For information on how to recycle LED/Fluorescent electronic products, please visit www.epa.gov.
- Do not install damaged product. This fixture is properly packed to prevent damage during transit.
- All wiring connections should be capped with UL approved recognized wire connectors.
- Do not touch LED diodes or any connecting clips; these parts are very sensitive.
- Do not exceed maximum wattage marked on fixture label.

<p>Carefully read the instructions pertaining to your fixture thoroughly. IF YOU HAVE ANY QUESTIONS REGARDING THE PROPER INSTALLATION OR LOCAL CODES, CONSULT A QUALIFIED ELECTRICIAN.</p>	<p>Lisez attentivement les instructions relatives à votre appareil complètement. SI VOUS AVEZ DES QUESTIONS CONCERNANT LES CODES DE POSE OU LOCAUX, CONSULTEZ UN ÉLECTRICIEN QUALIFIÉ.</p>
<p>Injury to persons and damage to the fixture and/or mounting surface may occur if the fixture is pulled from the surface. To reduce risk of injury or damage, mount only to a mechanically sound surface.</p>	<p>Blessure de personnes et dommages à l'appareil et / ou Surface de montage peut se produire si l'appareil est la surface. Pour réduire les risques de blessures ou de dommages, Seulement à une surface mécaniquement saine.</p>
<p>Both cord set and hard wired fixtures are intended for connection to a grounded, three-wire source of supply.</p>	<p>Les ensembles à cordon et les appareils câblés sont destinés Connexion à une source d'alimentation à trois fils mise à la terre.</p>
<p>Install and wire the fixture in locations in accordance with all national, state and local codes.</p>	<p>Installer et câbler l'appareil dans des endroits conformes aux Tous les codes nationaux, étatiques et locaux.</p>
<p>To avoid shock hazard, do not work with live electrical wires.</p>	<p>Pour éviter tout risque d'électrocution, ne pas travailler avec des fils.</p>
<p>Do not install outdoors or in applications other than intended use.</p>	<p>Ne pas installer à l'extérieur ou dans des applications autres que L'utilisation prévue.</p>
<p>Ensure fixture is properly grounded before testing.</p>	<p>Assurez-vous que l'appareil est correctement mis à la terre avant le test.</p>
<p>This fixture is intended for dry applications only.</p>	<p>Ce luminaire est réservé aux applications sèches.</p>

LED

LED RETROFIT STRIP LIGHT WITH LENS



WARNING: THIS PRODUCT MUST BE INSTALLED IN ACCORDANCE WITH THE APPLICABLE INSTALLATION CODE BY A PERSON FAMILIAR WITH THE CONSTRUCTIONS AND OPERATIONS OF THE PRODUCT AND THE HAZARDS INVOLVED.



ATTENTION: CE PRODUIT DOIT ÊTRE INSTALLÉ CONFORMÉMENT À L'INSTALLATION APPLICABLE CODE PAR UNE PERSONNE FAMILIALE AVEC LES CONSTRUCTIONS ET LES OPÉRATIONS PRODUIT ET LES DANGERS ENVOLVÉS.



WARNING: RISK OF FIRE; MINIMUM OF 90°C SUPPLY CONDUCTOR SHOULD BE USED. CONSULT A QUALIFIED ELECTRICIAN TO ENSURE CORRECT BRANCH CIRCUIT CONDUCTOR.



ATTENTION: RISQUE D'INCENDIE; MINIMUM DE 90 ° C DE CONDUCTEUR D'ALIMENTATION DOIT ÊTRE UTILISÉ. CONSULTEZ A ELECTRICIEN QUALIFIE POUR ASSURER UN CONDUCTEUR DE CIRCUIT DE BRANCHE CORRECT.



WARNING: TO AVOID ELECTRIC SHOCK HAZARD, DISCONNECT THE POWER AT THE PANEL BOARD (CIRCUIT BREAKER BOX) BEFORE BEGINNING INSTALLATION.



ATTENTION: POUR ÉVITER TOUT RISQUE D'ÉLECTROCUTION, DÉBRANCHEZ L'ÉNERGIE DU PANNEAU (CIRCUIT BREAKER BOX) AVANT DE COMMENCER L'INSTALLATION.



WARNING: TO AVOID FIRE HAZARD RISK, WHEN INSTALLING HARD WIRED UNITS, BE AWARE IF SUPPLY WIRES ARE LOCATED WITHIN THREE INCHES OF BALLAST. IF SO, USE WIRE RATED FOR AT LEAST 90°C (194°F). IF UNSURE, CONSULT A QUALIFIED ELECTRICIAN BEFORE INSTALLING.



ATTENTION: POUR ÉVITER LE RISQUE DE RISQUE D 'INCENDIE, LORS DE L' INSTALLATION D 'UNITÉ CÂBLÉE, CONSULTEZ SI L' APPROVISIONNEMENT LES FILS SONT SITUÉS DANS LES TROIS POUCHES DE BALLAST. SI CELUI-CI, UTILISEZ LE FIL POUR UN AU MOINS 90 ° C (194 ° F). SI VOUS ÊTES SÛR, CONSULTEZ UN ÉLECTRICIEN QUALIFIÉ AVANT D'INSTALLER.

<p>WARNING – Risk of fire or electric shock. Install this kit only in luminaires that have the construction features and dimensions shown in the photographs and/or drawings and where the input rating of the retrofit kit does not exceed the input rating of the luminaire.</p>	<p>AVERTISSEMENT – RISQUE D'INCENDIE OU DE CHOC ÉLECTRIQUE. L'INSTALLATION DE CE NÉCESSAIRE DE MODERNISATION EXIGE UNE PERSONNE FAMILIÈRE AVEC LA CONSTRUCTION ET LE FONCTIONNEMENT DU SYSTÈME ÉLECTRIQUE DU LUMINAIRE ET DES RISQUES ASSOCIÉS. TOUTE PERSONNE QUI N'EST PAS QUALIFIÉE NE DOIT FAIRE AUCUNE TENTATIVE D'INSTALLATION ET DOIT CONTACTER UNE PERSONNE QUALIFIÉE.</p>
<p>WARNING – To prevent wiring damage or abrasion, do not expose wiring to edges of sheet metal or other sharp objects.</p>	<p>AVERTISSEMENT – AFIN DE PRÉVENIR L'ENDOMMAGEMENT OU L'ABRASION DES CÂBLES, ÉVITER TOUT CONTACT ENTRE CES DERNIERS ET LE BORD D'UN OBJET TRANCHANT TEL QU'UNE TÔLE.</p>
<p>DO NOT MAKE OR ALTER ANY OPEN HOLES IN AN ENCLOSURE OF WIRING OR ELECTRICAL COMPONENTS DURING KIT INSTALLATION.</p>	<p>IL EST INTERDIT DE FAIRE OU DE MODIFIER UNE OUVERTURE DANS UN BOÎTIER DE CÂBLAGE OU DE COMPOSANTS ÉLECTRIQUES AU COURS DE L'INSTALLATION DU NÉCESSAIRE.</p>
<p>THIS RETROFIT KIT IS ACCEPTED AS A COMPONENT OF A LUMINAIRE WHERE THE SUITABILITY OF THE COMBINATION SHALL BE DETERMINED BY AUTHORITIES HAVING JURISDICTION.</p>	<p>LE NÉCESSAIRE DE MODERNISATION EST ACCEPTÉ À TITRE DE COMPOSANT D'UN LUMINAIRE LORSQUE LA PERTINENCE DE LA COMBINAISON DOIT ÊTRE DÉTERMINÉE PAR PAR LES AUTORITÉS COMPÉTENTES.</p>

LED

LED RETROFIT STRIP LIGHT WITH LENS



1



REMINDER: TO AVOID ELECTRIC SHOCK HAZARD, DISCONNECT THE POWER AT THE PANEL BOARD (CIRCUIT BOX) BEFORE BEGINNING INSTALLATION!

2

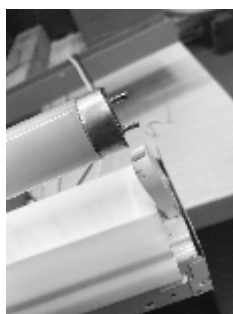

Retrofit only! Otherwise skip to Step 7: Remove all existing lamps.

3

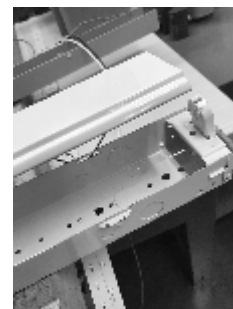

Remove the ballast cover from the fixture.

4



Remove the sockets from the socket bars.

5

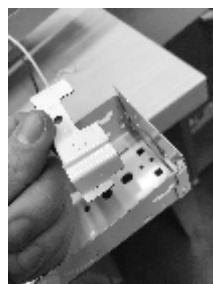

Remove the socket bars from the pan.

6



Remove the ballast from the pan.

7

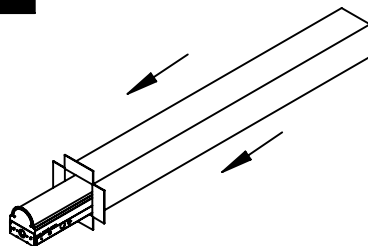

Carefully remove fixture from packaging. Use gloves to prevent dirt and oils from transferring to the unit. Inspect the fixture for any defects before proceeding.

8

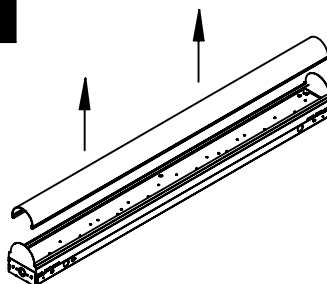

CAUTION: EDGES MAY BE SHARP: For easier installation, carefully remove lens from fixture by gently un-snapping one side at a time, and set aside.

9

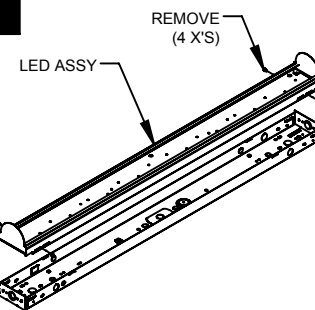

Remove LED assy from the C-Strip by removing (4) screws. **For retrofit, skip to Step 12.**

LED

LED RETROFIT STRIP LIGHT WITH LENS



10

Remove 7/8" knockout from bottom of fixture in desired location to allow for wiring.

11

Mount fixture to secure structure using mounting holes as shown above (if pendant mounting, attach pendant mount stud using 1/2" knockout before proceeding to Step 13).

12

Wire fixture according to all national, state and local codes. Test fixture.

13

Reinstall the LED assy by completing Step 9 in reverse. Wire fixture according to all national, state and local codes. Test fixture.

14

CAUTION: EDGES MAY BE SHARP: Reinstall the lens to the fixture.

15

PENDANT MOUNT OPTION: Bring stud of hanging kit through 1/2" knock-out and secure using nut provided (see HC-301/302 assembly instructions for details).

16

TONG HANGER OPTION: Insert tong hooks in to oblong cut outs, and rotate hanger so that the hooks exit the fixture thru the exit point. Attach chain as needed.