

INSTALLATION INSTRUCTIONS FOR THE SKD SERIES FIXTURE

APPLICATION: General/Perimeter Lighting



STOP! - READ THIS FIRST! - IMPORTANT SAFETY INSTRUCTIONS!

- For information on how to recycle LED/Fluorescent electronic products, please visit www.epa.gov.
- Do not install damaged product. This fixture is properly packed to prevent damage during transit.
- All wiring connections should be capped with UL approved recognized wire connectors.
- Do not touch LED diodes or any connecting clips; these parts are very sensitive.
- Do not exceed maximum wattage marked on fixture label.

Carefully read the instructions pertaining to your fixture thoroughly. IF YOU HAVE ANY QUESTIONS REGARDING THE PROPER INSTALLATION OR LOCAL CODES, CONSULT A QUALIFIED ELECTRICIAN.	Injury to persons and damage to the fixture and/or mounting surface may occur if the fixture is pulled from the surface. To reduce risk of injury or damage, mount only to a mechanically sound surface.
Both cord set and hard wired fixtures are intended for connection to a grounded, three-wire source of supply.	Install and wire the fixture in locations in accordance with all national, state and local codes.
Do not install outdoors or in applications other than intended use.	To avoid shock hazard, do not work with live electrical wires.
Ensure fixture is properly grounded before testing.	This fixture is intended for damp applications.



WARNING: THIS PRODUCT MUST BE INSTALLED IN ACCORDANCE WITH THE APPLICABLE INSTALLATION CODE BY A PERSON FAMILIAR WITH THE CONSTRUCTIONS AND OPERATIONS OF THE PRODUCT AND THE HAZARDS INVOLVED.



WARNING: RISK OF FIRE; MINIMUM OF 90°C SUPPLY CONDUCTOR SHOULD BE USED. CONSULT A QUALIFIED ELECTRICIAN TO ENSURE CORRECT BRANCH CIRCUIT CONDUCTOR.



WARNING: TO AVOID ELECTRIC SHOCK HAZARD, DISCONNECT THE POWER AT THE PANEL BOARD (CIRCUIT BREAKER BOX) BEFORE BEGINNING INSTALLATION.



WARNING: TO AVOID FIRE HAZARD RISK, WHEN INSTALLING HARD WIRED UNITS, BE AWARE IF SUPPLY WIRES ARE LOCATED WITHIN THREE INCHES OF BALLAST. IF SO, USE WIRE RATED FOR AT LEAST 90°C (194°F). IF UNSURE, CONSULT A QUALIFIED ELECTRICIAN BEFORE INSTALLING.

1



REMINDER: TO AVOID ELECTRIC SHOCK HAZARD, DISCONNECT THE POWER AT THE PANEL BOARD (CIRCUIT BOX) BEFORE BEGINNING INSTALLATION!

2

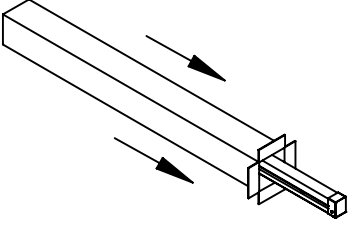

Carefully remove fixture from packaging. Use gloves to prevent dirt and oils from transferring to the unit. Inspect the fixture for any defects before proceeding.

3

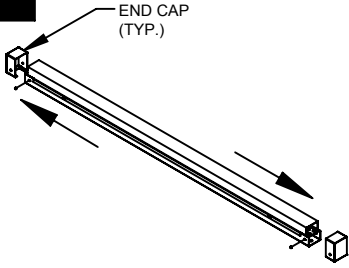

END CAP (TYP.)

Take off the end caps by removing (2) screws. Repeat on the opposite end.

4

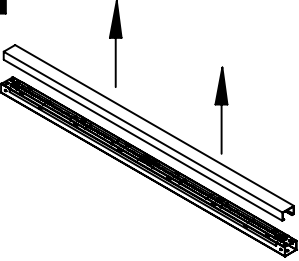

CAUTION: EDGES MAY BE SHARP: Carefully remove lens from fixture by gently un-snapping one side at a time, and set aside.

5

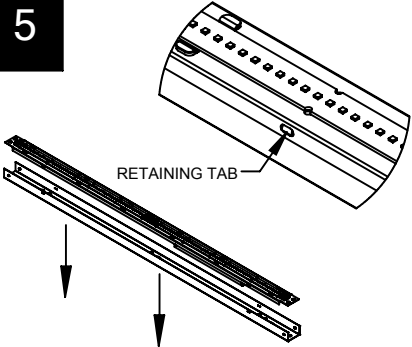

RETAINING TAB

Remove the gear tray by gently squeezing in on the sides of the pan under the retaining tab. Start on end of the fixture, working towards the other.

6

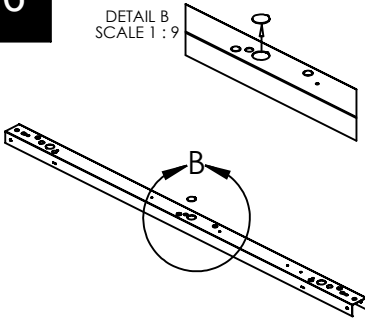

DETAIL B SCALE 1 : 9

Remove 7/8" knockout from bottom of fixture in desired location to allow for wiring.

7

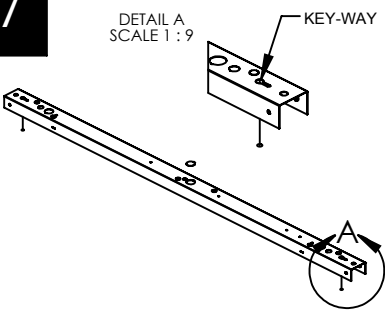

DETAIL A SCALE 1 : 9

KEY-WAY

Bringing the supply line thru the knockout, use key-ways to mount the pan in desired location with appropriate hardware.

8

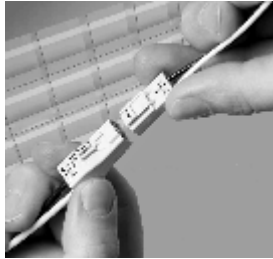

Wire fixture according to all national, state and local codes. Test Fixture.

9

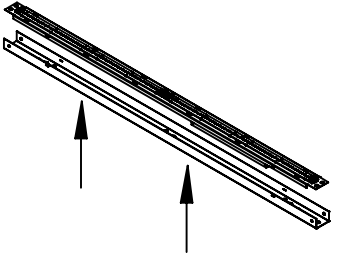

Re-install the gear tray to the pan by lining up the tabs on the pan to the slots on the gear tray, and gently snapping the tabbed side back in to place.

10

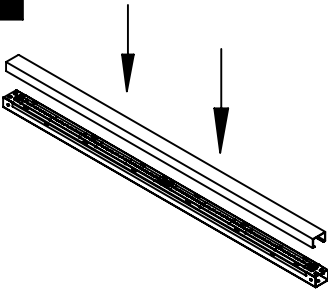

Re-install the lens by following step 4 in reverse, gently snapping the lens in to place.

11

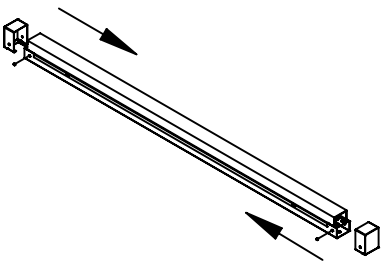

Re-install the end caps by following step 3 in reverse, making sure to re-install the screws.