

INSTALLATION INSTRUCTION MANUAL

Item number:
LDL-6-13-120D-930-WH

PACKAGING CONTENTS

A.LED module and connector

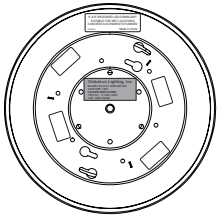

B.(2)#8-32 x 1-3/8 in.
junction box screws(use the size that
fits your junction box)

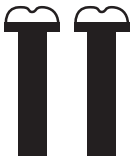

C.Green ground wire with
#8-32 x 5/16 in. machine screw
and #8-32 hex nut

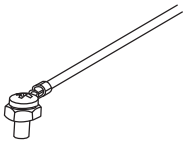

D.(3)Wire Nuts

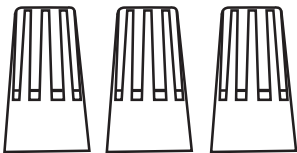

ITEMS REQUIRED

(Purchase separately)

- #2 Screwdriver

IMPORTANT SAFETY INSTRUCTIONS

When using product,basic precautions should always be followed,including the following:

- Heed all warnings,including below warnings and those included on product.
- Disk Light (fixtures) and retrofits are designed to meet the latest NEC requirements and are ETL/cETL listed in full compliance with UL 1598. This code sets the wiring standards for your locality and should be carefully studied before starting.

- Read and follow these instructions.
- Risk of fire.MINIMUM 90°C SUPPLY CONDUCTORS.
- Risk for Fire or Electric Shock:Please consult an electrician for installation if uncertain of housing electrical systems.
- Risk of electric shock.To avoid possible electrical shock,be sure that power supply is turned off at fuse box or circuit breaker before installing or servicing fixture.
- To prevent wiring damage or abrasion,do not expose wiring to edges of sheet metal or other sharp objects.

CAUTION

- Connect fixture to a 120volt,60Hz power source.Any other connection voids the warranty.
- Fixture should be installed by persons with experience in household wiring or by a qualified electrician.The electrical system,and the method of electrically connecting the housing to it,must be in accordance with the National Electrical Code and local building codes.
- This device complies with Part 15 of the FCC Rules.Operation is subject to the following two conditions:
 - (1) this device may not cause harmful interference;
 - (2) this device must accept any interference received,including interference that may cause undesired operation;
- Do not make or alter any open holes in an enclosure of wiring or electrical components during kit installation .

SAVE THESE INSTRUCTIONS AND WARNINGS.

Disk Light is designed for dimming with many 120V Leading Edge(LE) and Trailing Edge (TE) phase control dimmers. Dimming capability may be enhanced with select dimmers that feature low end trim adjustment.(Consult dimmer manufacturer for specific load compatibility and application information. (Note some dimmers require a neutral in the wallbox.) For the latest Disk Light product information , please refer to specifications online at www.globaluxlighting.com.

DETERMINING WHICH INSTALLATION METHOD TO USE

This module can be mounted to recessed mounted standard junction boxes with junction box bracket .

ELECTRICAL JUNCTION BOXES

Mounting to recessed mounted standard junction boxes

NOTE: The module installs onto many standard recessed ceiling and wall mounted junction boxes(Fig.1)

- 4" octagon; 2 1/8" Deep
- 4" square; 2 1/8" Deep
- 4" round; 2 1/8" Deep

(Box types and site condition vary. Installer to ensure compatibility at fit, wiring and proper mounting) The junction box must be a minimum 2 1/8 inch in depth for proper installation.

Recommended boxes shown in Fig 1.

Fig.1

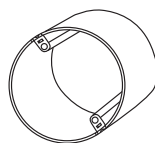

Round-2 1/8"
minimum depth

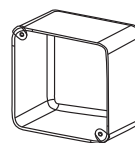

Square-2 1/8"
minimum depth

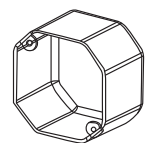

Octagonal-2 1/8"
minimum depth



MOUNTING TO A JUNCTION BOX:

1. Rotate the housing counterclockwise to make them separated (see Fig. 2).

Fig.2

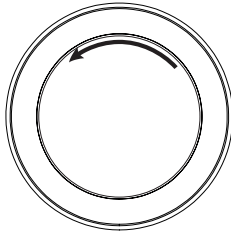

2. Tear the "4" J-BOX Installation Hole" label on the back of the LED Disk Light (see Fig. 3).

Fig.3

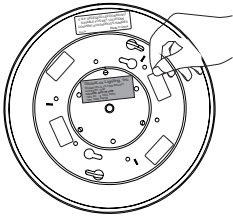

3. Connect the Supply Wire Adapter to the house supply wires. Using the included wire nuts, connect adapters black wire to hot supply wire and connect adapters white wire to supply neutral wire. Connect the ground wire (attached to the bracket) to the ground wire in the junction box using the included wire nuts (Fig. 4).

Fig.4

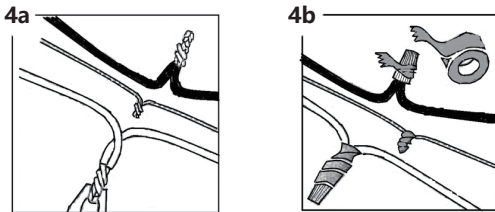

Recommended junction boxes in Figure 1.

4. Arrange the supply wire adapter as shown in Figure 6 into the back of the junction box.
5. Align appropriate holes (Fig 5) in the mounting bracket with the holes in the junction box. Using 2 of the longer screws (either #6 or #8 screws depending on the size of the holes in your junction box) attach the mounting bracket to the junction box. Tighten screws until bracket is flush with the ceiling. Do not over-tighten screws or fixture will not be tight to ceiling (Fig. 6). For wet location rating, LED module must be flush to the ceiling.

Fig.5

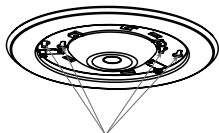
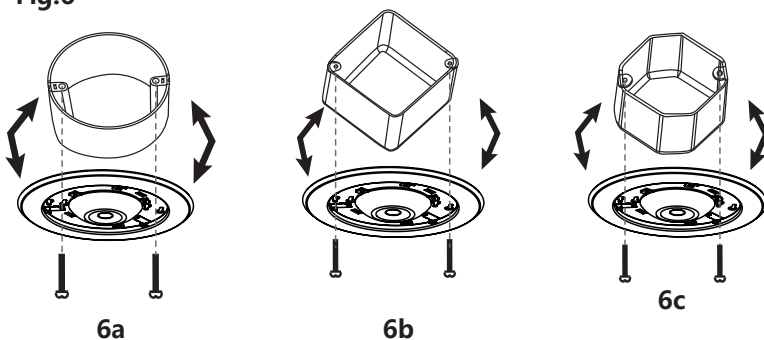
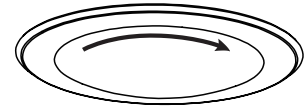

Fig.6



6. Connect the orange plug of the Supply Wire adapter to the orange plug of the LED module and arrange orange connection behind mounting bracket.
7. Rotate the housing clockwise to make them together (see Fig. 7)

Fig.7



GROUND WIRE ATTACHMENT IN RECESSED HOUSINGS

NOTE: Green ground wire must be securely installed to the Junction Box. Three connection methods shown below.

1. For ground connection from LED module to the Junction Box, use provided green ground wire.
2. Connect other end of green ground wire to the Junction Box.
 - Use supplied #8 screw in existing hole (Fig. 8).

Fig.8

(View from inside the housing)

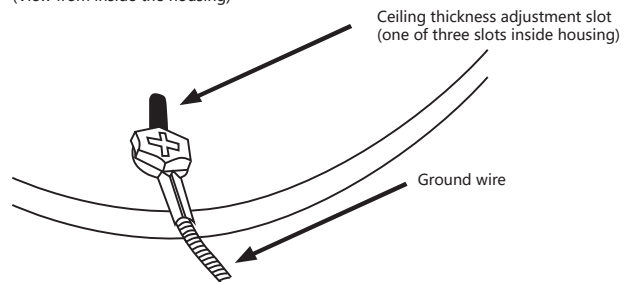

WARNING:

For WET locatin applications, after fixture is installed on ceiling, put silicone glue to seal the gap between fixture and ceiling.