

LED Center Basket

DIMENSIONS

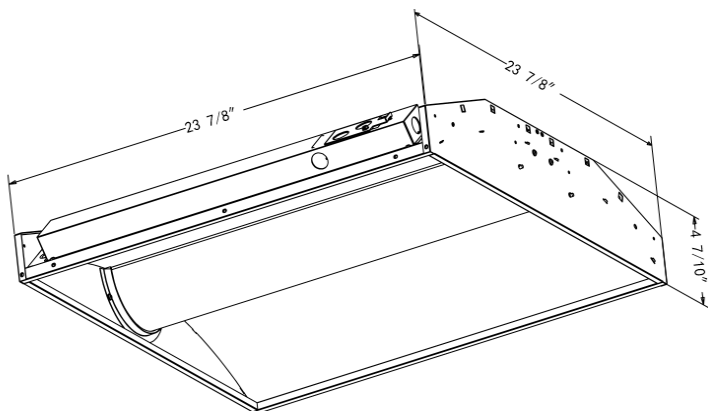

APPLICATION

The new GlobalLux LED Architectural LCD's fixture adopts the latest in optical and LED technology for use in many commercial applications. The LCD provides a very pleasant volumetric soft light that fills any interior space giving it a larger, brighter, and more productive ambiance and will be the perfect fit for any commercial or institutional application. Designed to lay in drop ceilings in offices, schools and healthcare application. The LCD Series is fully dimmable and are compatible with building controls, motion sensors, and daylight harvesting systems. The design of the LCD series panels produces an even and consistent shadow-less light. The LED's enable long life, high lumen maintenance, high CRI, are low maintenance, and constructed without hazardous materials.

FEATURES

- All reflective surfaces are finished after fabrication with high reflectivity white paint for uniform illumination.
- Enclosed high efficiency lens provides visual comfort and high performance without pixelation
- Equipped standard with a 0-10V continuous dimming driver that works with any standard 0-10V control/dimmer
- Low W/ft2 ratio typically meets most restrictive lighting power density codes
- Long life, 60,000 hour LEDs at L80 reduce life cycle maintenance costs
- Optional On/Off or Bi Level Motion Sensor, High voltage transformers, emergency battery backups, cords and whips

CONSTRUCTION

Rugged construction, solid die formed, cold-rolled steel housing. All surfaces powder coated after fabrication. Frosted acrylic diffuser provides even consistent light while reducing glare.

MOUNTING

Suitable for recessed mounting within T-Bar grid.

ELECTRICAL

Equipped standard with 0-10V continuous dimming driver that works with any standard 0-10V control/dimmer. Long-Life LED's 60,000 hours at L80 with projected life over 100,000 hours for reduced life cycle maintenance costs.

CERTIFICATION

All luminaires are built to UL 1598 and 2108 standards, and bear appropriate ETL labels. Wet location labeling is standard. Emergency equipped fixtures labeled UL924. Adheres to LM70, LM80, and TM21 industry standards. Design Lights Consortium (DLC) qualified product. Not all models of this product maybe DLC qualified. Please check the DLC Product List.

WARRANTY

5-year limited warranty. See complete warranty for terms and exclusions. (Labor not included).

ORDERING INFORMATION

Example Model Number: LCD-22-40-MVD-850-EML8

SERIES	FORM FACTOR	RATED WATTAGE	DRIVER TYPE	CRI AND KELVIN	OPTIONS
LCD	22-2'x2' ² Housing 24-2'x4' ² Housing	2x2 Housing 40- 40W 4000 Lumens ² 26- 26W 3100 Lumens ^{1 3} 2x4 Housing 52- 52W 5200 Lumens ² 42-42W 5400 Lumens ^{1 3}	MVD- 120-277V; 0-10V Dimming ² HVD-347-480V,0-10V Dimming	835 - 80 CRI; 3500 Kelvin ^{1 2} 840 - 80 CRI; 4000 Kelvin ² 850 - 80 CRI; 5000 Kelvin ^{1 2}	MOS- Integrated Microwave Sensor, On/Off FW3- 6', 3 Wire Fixture Whip FW4- 6', 4 Wire Fixture Whip MOSB- Integrated Bi Level Microwave sensor EML8- Emergency Battery Pack, 800 Lumens EML16- Emergency Battery Pack, 1400 Lumens

Notes:
¹Made to order items. Minimum 90 day lead time. Minimum 500 order quantity.
²DLC Listed
³DLC Premium Listed
⁴Quick ship: XK. Other CCTs may require lead time or special orders.
⁵Typical color consistency may vary or be changed