



INSTALLATION GUIDE

MODEL #: EPN22-1040s-2 / EPN22-1050s-2

MODEL #: EPN24-1040s-2 / EPN24-1050s-2

LED Panel Series | 2x2 Class

2 ft. x 2 ft. All in One Retrofit Kit

LED Panel Series | 2x4 Class

2 ft. x 4 ft. All in One Retrofit Kit

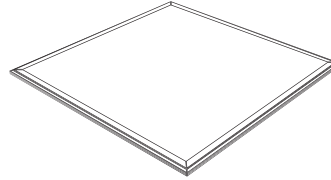

LED Panel
2 ft. x 2 ft.
2 ft. x 4 ft.

PLEASE REVIEW THE INSTRUCTIONS AND WARNINGS LISTED BELOW PRIOR TO PROPER INSTALLATION

WARNINGS	CAUTIONS
<ul style="list-style-type: none"> • Risk of fire / electrical shock . • LED Panel installation requires knowledge of luminaire electrical systems. • Risk of electric shock – disconnect power at source before installation. • Do not make or alter any open holes in an enclosure of wiring or electrical components during installation. • If lamp or luminaire exhibits abnormal operation (buzzing, flickering, minimal light, etc.), turn off power, remove luminaire and contact us. <p>For more information please visit www.eurilighting.com or call our toll-free number 1-888-743-5766.</p>	<ul style="list-style-type: none"> • Do not look directly at the operating LED Panel. • Do not touch this product with wet hands. • Do not disassemble, repair or alter lamp. • Designed for indoor applications only. • Suitable for damp locations. • The luminaires should be grounded. • This device is not intended for use with emergency exits or emergency lights. • Please make sure the driver supply wiring is of adequate length and rating. Avoid any tension. • Observe proper polarity when connecting power to driver. Unit must be grounded as per code. L = Input Line or Hot, W = Neutral • All connections should be according to NEC or any applicable local code. • Wear gloves and safety glasses every time when working with the luminaire for installing, servicing or performing maintenance.

INSTALLATION INSTRUCTIONS - Wiring the Driver

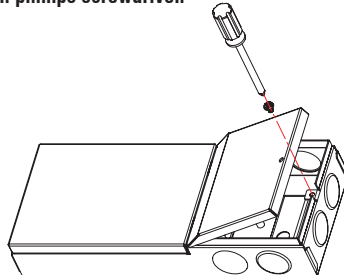
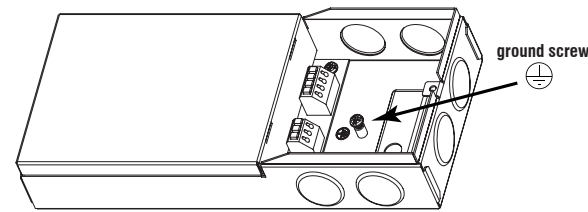
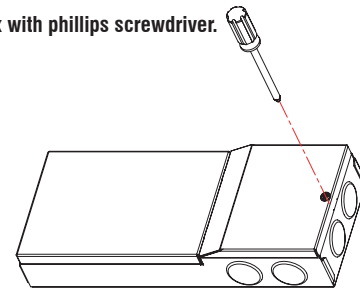
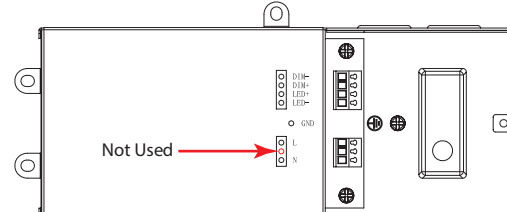
<p>STEP 1: Open the cover of junction box with phillips screwdriver.</p> 	<p>STEP 2: Remove round knock-out and connect conduit to wiring box with proper connectors: press the binding post with flat screwdriver, insert the wire and secure. For AC input, connect neutral wire(White) to AC-N, Live wire(Black) to AC-L and Ground wire(Green) to the ground screw - ⊕. For 0-10V dimmer wiring: connect the dimmer+ wire to the DIM+, connect the dimmer- wire to the DIM-.</p> 
<p>STEP 1: Open the cover of junction box with phillips screwdriver.</p> 	

Additional mounting hardware not included



INSTALLATION GUIDE

MODEL #: EPN22-1040s-2 / EPN22-1050s-2

MODEL #: EPN24-1040s-2 / EPN24-1050s-2

LED Panel Series | 2x2 Class

2 ft. x 2 ft. All in One Retrofit Kit

LED Panel Series | 2x4 Class

2 ft. x 4 ft. All in One Retrofit Kit

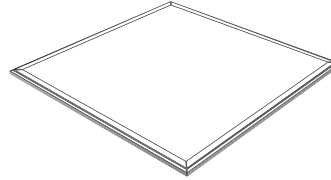

LED Panel

2 ft. x 2 ft.

2 ft. x 4 ft.

RECESSED INSTALLATION FOR DROP-DOWN CEILINGS

STEP 1:
Move away ceiling tile.

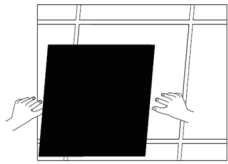

STEP 2:
Connect power supply.

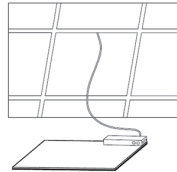

STEP 3:
Put the panel light into framework.

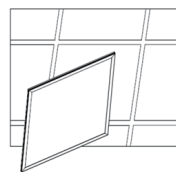

STEP 4:
Finish the installation.

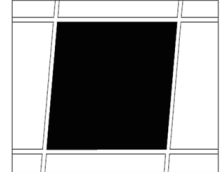

T-bar clips should be bent outwards to provide additional safety and support.
Additional support means may be required by local or national codes.

Hole provided may be used to further secure fixture from above.

Notes:

Secure to grid per state and local codes.

Ceiling grid must adequately support weight of fixture.

