

# LED MINI WALL PACKS

17W / 25W

## INSTALL INSTRUCTIONS



### SPECIFICATIONS

ITEM#	DESCRIPTION	WATT	COLOR	LUMENS	CRI	VOLT	HOURS
83216NP	LED MINI WALL PACK/BLACK/17W/40K/120-277V - SUPERIOR LIFE®	17	4000K	1685	83	120-277V	50,000
83216PC	LED MINI WALL PACK/BLACK/17W/40K/PHOTO CELL/120V - SUPERIOR LIFE®	17	4000K	1685	83	120V	50,000
83217NP	LED MINI WALL PACK/BLACK/25W/40K/120-277V - SUPERIOR LIFE®	25	4000K	2126	83	120-277V	50,000
83217PC	LED MINI WALL PACK/BLACK/25W/40K/PHOTO CELL/120V - SUPERIOR LIFE®	25	4000K	2126	83	120V	50,000

### WARNING

- To avoid electric shock, disconnect power at source prior to installation.
- The installation should be performed by qualified electricians or lighting technicians.
- Before conducting any installation, maintenance, or removal, disable all power to the luminaries and wait until the fixture cool down.
- Do not touch the fixture while it is in service.
- If there is any problem with the fixture, DO turn off power and DO NOT attempt repair unless you are a qualified technician or the customer service member.
- The electrical rating of 83216NP and 83217NP is 120-277V AC. Items 83216PC and 83217PC have a photo cell and are 120V. Please read the label information carefully to get proper input voltage for this product.
- Suitable for wet locations

### INSTALLATION

#### 1. MOUNTING WITH A 1/2" CONDUIT AT THE BOTTOM

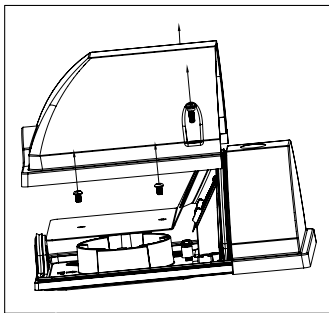

1. Removing the lens by loosening the two screws on the sides of the lens, removing the reflector by loosening the two screws.

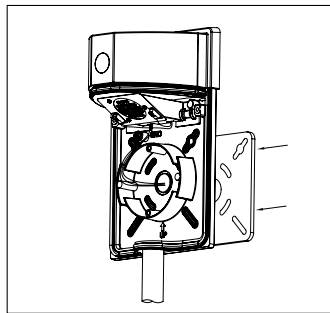

2. Remove the threaded plug from the bottom, Plug the 1/2" conduit into the fixture, knock out 2 screw holes on the back housing and attach the fixture on the wall with proper screws, use the supplied gasket for a weather tight seal.

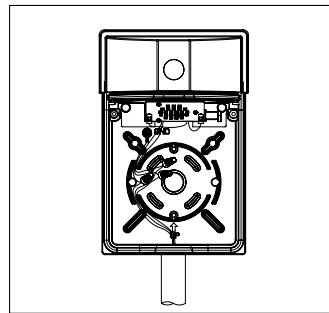

3. Connect Black for line, White for Neutral and bare wire for Ground to complete the wiring.

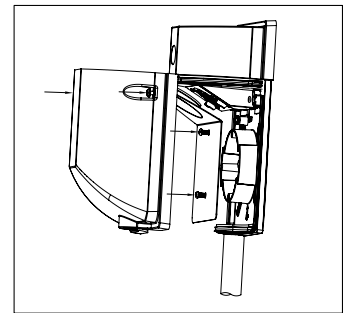

4. Replace the reflector and lens carefully by reversing procedure used to remove it.

#### 2. MOUNTING WITH J-BOX

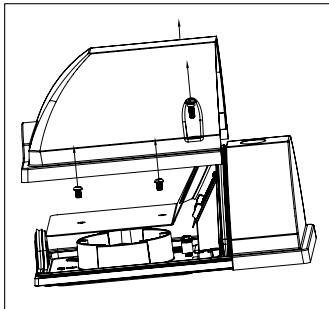

1. Removing the lens by loosening the two screws on the sides of the lens, removing the reflector by loosening the two screws.

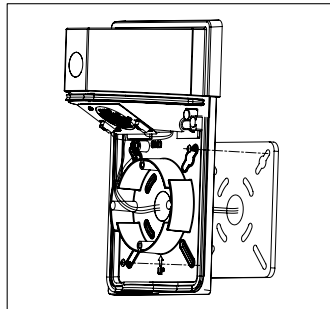

2. Knock out the 2 screw holes and the holes in the center of the back housing, Plug the wires from the J-BOX into the fixture through the center hole, and attach the fixture to the J-box with proper screws. use the supplied gasket for a weather tight seal.

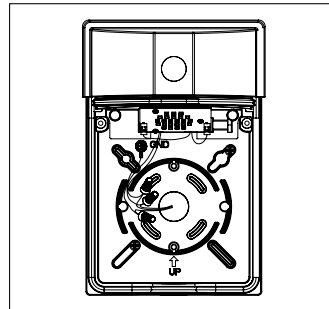

3. Connect Black for line, White for Neutral and bare wire for Ground to complete the wiring.

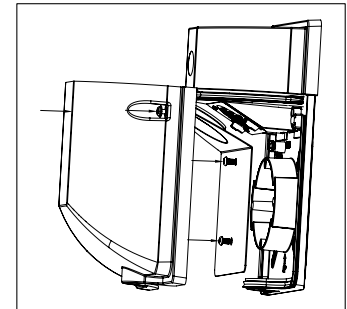

4. Replace the reflector and lens carefully by reversing procedure used to remove it.