

Single Pole (One Location)  
**Wireless Occupancy Sensor Products**  
 Cat. No. WSS10, WSC04, WSC15, and WSS0S  
 Incandescent: 800W @ 120V – Ballast: 1200VA @ 120V, 2700VA @ 277V  
 120-277VAC, 50/60Hz, Motor: 1/4 HP @ 120V  
**INSTALLATION INSTRUCTIONS**

**WARNINGS AND CAUTIONS:**

- To be installed and/or used in accordance with appropriate electrical codes and regulations.
- If you are unsure about any part of these instructions, consult a qualified electrician.
- WSS10-GDx products do not require a neutral wire, there is a minimum requirement of 25 watts for these products.

**WARNINGS AND CAUTIONS:**

- Disconnect power at circuit breaker or fuse when servicing, installing or removing fixture.
- Use this device only with copper or copper clad wire.
- Recommended minimum wall box depth is 2-1/2".

PK-93664-10-00-0B

**Description**

Cat. No. WSS10 is the receiver switch. This switch has a single switch pad that toggles the relay and its corresponding load, ON and OFF. If the relay is OFF, the relay will turn ON when the push-button is pressed, and vice-versa. The Indicator LED will blink Red when a flag/packet is received from the sensor or remote switch. **NOTE:** the no-neutral version has a minimum load requirement of 25 watts.

Cat. No. WSCxx is the sensor(s). The Sensor Unit sends a flag/packet with the presence of motion to the receiver switch which then keeps the load ON. In the absence of motion, the Sensor Unit will stop sending flag/packets to the receiver switch; when the receiver switch no longer receives a packet, the Time Out will start, then time-out and turn the relay OFF. Time Delay starts as of the last motion detected in the space. The Motion Indicator LED will blink Red (1 blink per minute) every time motion is detected, sending a flag/packet to the receiver.

- **WSCxx & WSS10 (together):** In Manual-ON/Auto-Off mode, the button must be pressed to turn the lights ON. In the absence of flags/packets sent from the sensor, the receiver switch will Time-Out and turn the lights OFF.
- **WSCxx & WSS10 (together):** In Auto-ON/Auto-Off mode, the sensor will send a flag/packet to the receiver to turn the lights ON. In the absence of flags/packets sent from the sensor, the receiver switch will Time-Out and turn the lights OFF. **NOTE:** The sensor must sense motion and send a packet to start the time delay and enable Auto-Off.
- **WSCxx & WSS10 (together):** They allow the 30 second vacancy confirmation feature which exists to turn the relay back ON in case of false OFF.

**Self Powered Products:** The sensor and remote switch are self powered devices using EnOcean technology.

- The Sensor utilizes a solar panel which powers the sensor from the rooms ambient light. The sensor will start to function within a minute of exposure to light. The total charge time for the sensor will vary depending on intensity of light and length of exposure to light. The minimum light requirement for the sensor is 40LUX (4FC).
- The remote switch utilizes kinetic energy from the mechanical switch when pushing the pad. This friction then stores enough energy to transmit another signal on the next press action of the pad, tested over 50,000 cycles.

**Battery option:** The use of (3) AAA batteries (not included) is not required but can be used in areas where no light is expected for long periods of time.

**Low Voltage option:** The 5-24VDC connection, is provided and recommended when used in areas where no light is expected for long periods of time.

**Tools needed**

- Slotted/Phillips Screwdriver
- Electrical Tape
- Pliers
- Pencil
- Wire Cutters
- Ruler
- Wire Nuts

**Changing the color of your Switch**

Color change options are available from Leviton, consult you local Leviton Distributor. To change color of frame, proceed as follows:

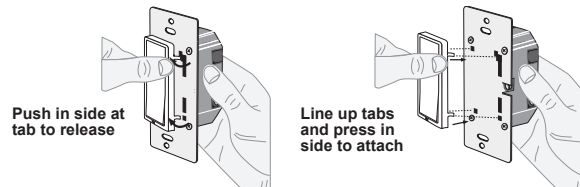

**Installation**

**NOTE:** Use check boxes  when Steps are completed.

**Step 1** **WARNING: TO AVOID FIRE SHOCK OR DEATH; TURN OFF POWER** at circuit breaker or fuse and test that power is off before wiring!

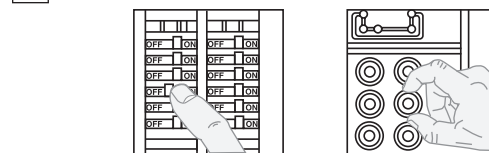

**Step 2** **Identifying your wiring application (most common):**

**NOTE:** If the wiring in your wall box does not resemble this configuration, consult an electrician.

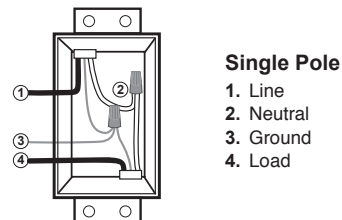

**Step 3** **Single Pole Wiring Application:**

- WSS10 Receiver Control Switch is only intended as a Single Pole device.

**Multiple Location Wiring Application:**

- WSS0S Wireless Remote Switch can be used for additional switches (3-way and 4-way), no wires necessary.

**WIRING SWITCH:**

Connect wires per **WIRING DIAGRAM** below as follows:

- Connect (Hot) wire from wall box to black wire on switch.
- Connect (Load) wire in wall box to blue wire on switch.
- Connect (Neutral) wire in wall box to white wire on switch.

**NOTE:** For No Neutral model, white wire will not be available.

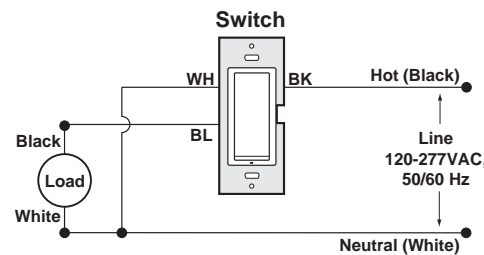
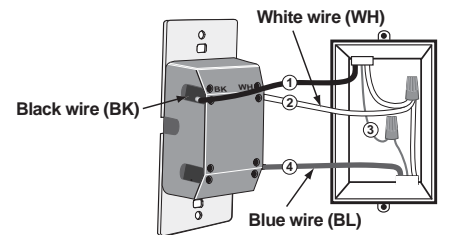

**Step 4** **Dip Switch Settings:**

**NOTE:** To access dip switch settings, lift up the bottom of the switch pad.

**Auto ON / Auto Off mode:** Auto mode can be enabled using the dip switches, product comes from the factory in Manual On/ Auto Off.

**Walk-through:** can be used only in Auto-ON mode and is recommended only when using batteries or low voltage power connection.

**Timeout:** 2 (test), 10, 20, 30min; (Longer time delay is recommended for continuous self powering of the sensor and to ensure packets are sent to the receiver switch).

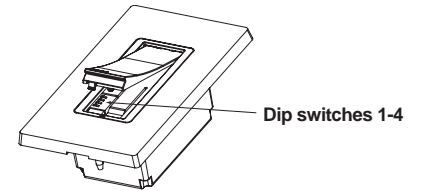

| DIP SWITCH SETTINGS |                  |                    |
|---------------------|------------------|--------------------|
| Dip Switch          | OFF Position     | ON Position        |
| 1                   | Auto ON/Auto OFF | Manual ON/Auto OFF |
| 2                   | Walk Through OFF | Walk Through ON    |
| 2 Min Time-Out      |                  |                    |
| 3                   | X                | -                  |
| 4                   | X                | -                  |
| 10 Min Time-Out     |                  |                    |
| 3                   | X                | -                  |
| 4                   | -                | X                  |
| 20 Min Time-Out     |                  |                    |
| 3                   | -                | X                  |
| 4                   | X                | -                  |
| 30 Min Time-Out     |                  |                    |
| 3                   | -                | X                  |
| 4                   | -                | X                  |

**Factory settings:**

WSS10: Manual On/AutoOff, Walk thru = disabled, Time delay = 10min.  
 WSCxx: Range (PIR sensitivity) = 75%

**Factory setting operation:**

When entering the room, the wireless receiver control switch will need to be manually turned ON. Once learned into the receiver switch, the Wireless occupancy sensor will send flag/packets to the receiver switch, keeping the lights on until the room is vacant. Once the sensor stops sending flag/packets, the receiver time out will start, then turn the lights OFF after timeout period.

**Time-Outs:**

The Sensor has four time-out settings: 2 (test), 10, 20, or 30 min. (longer timeout is recommended for self powering in dark spaces). The values of time-out is user selected through the use of the Dip Switch Settings.

**NOTE:** Since the sensor is only sending a packet every minute, the 2 minute time delay is not sufficient for normal operation.

**Walk-Through Time Delay:**

The walk-through feature is only active in the Auto-On/Auto-Off mode with time delay of 10, 20 or 30min, is useful when a room is momentarily occupied. With this feature, the Sensor will turn the lights OFF shortly after the person leaves the room. The walk-through feature works in the following manner: When a person enters the room, the lights will turn ON. If the person leaves the room before the walk-through time-out of 2.5 minutes, the Sensor will turn the lights OFF within 2.5 minutes of no occupancy detected. If the room is occupied for longer than 2.5 minutes, the Sensor will enter the Occupied Mode with the time-out duration specified by the Dip Switch setting.

## Step 5 Programming:

### LEARN MODE (to Learn devices):

When using the Wireless Occupancy Products together, they must be paired to the other devices to perform as desired.

- **WSC04 and WSC15** - Wireless Occupancy Sensor(s) – has learn button on device, under front plastic tab
- **WSS10** - Wireless Receiver Control Switch - use switch pad for learning
- **WSS0S** - Wireless Remote Switch - use switch pad for learning

**STEP A)** To enter programming, press and hold the Receiver Control Switch (WSS10) switch pad for 15 seconds. The receiver will then enter programming and flash AMBER.

There are 2 modes in programming, LEARN and CLEAR modes. Tap the switch pad to toggle between the two programming modes

- 1 AMBER LED flash = LEARN mode
- 2 AMBER LED flashes = CLEAR mode

**STEP B)** Select the desired programming (LEARN or CLEAR) mode, press and hold the pad for 5 seconds to ENTER the desired mode (**continue to step C or D**).

**STEP C)** Press the learn buttons on each of the devices you want to learn into the receiver switch.

- Remote switch, you must press the switch pad to send a signal for learning.
- Occupancy sensor, you must press the learn button on the front of the sensor under plastic tab to send a signal for learning.
- AMBER LED on for 2 seconds = acknowledgement, device is learned.

**NOTE:** Press the learn button once to learn. Pressing it more than once will unlearn the device.

### LED feedback/indicators in learn mode:

- 1 Red flash = no learned devices
- 1 Green flash = 1 learned devices
- 2 Green flashes = 2 learned devices
- 3 Green flashes = 3 learned devices
- Etc. (up to 6 devices)

**To Un-Learn a single device:** Press the remote switch or occupancy sensor learn button again and the address will be removed.

- GREEN LED on for 2 seconds = device is unlearned

**To EXIT:** (programming/learn/clear) Wait 15 seconds and the device will automatically exit.

### CLEAR MODE (to clear All Devices):

- Start at the beginning with STEPS A and B above.
- 1 Red flash = no learned devices
- Multiple Green flashes = devices exist

**STEP D)** Press and hold the switch pad for more than 5 seconds. After the button is released, the LED will flash red to confirm all learned devices have been cleared and then the device will exit programming.

**NOTE:** Product will leave the programming learn or clear modes, without change, after 15 seconds of inactivity.

## WSC04/WSC15

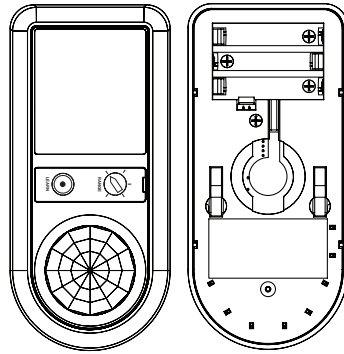

## WSS10

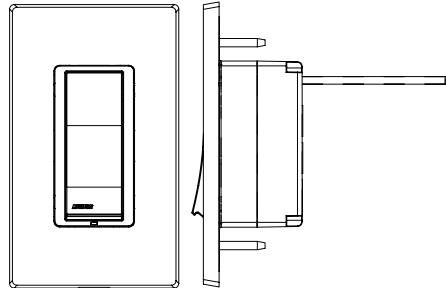

## WSS0S

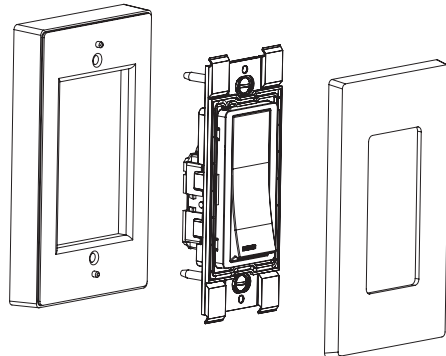

## Step 6 Testing your Switch prior to mounting in wall box:

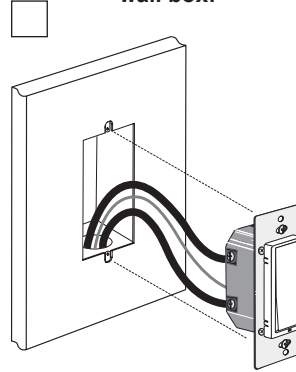

- Position all wires to provide room in outlet wall box for device.
- Ensure that the word "TOP" is facing up on device strap.
- Partially screw in mounting screws in wall box mounting holes.

**NOTE:** Dress wires with a bend as shown in diagram in order to relieve stress when mounting device.

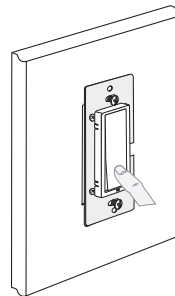

- Restore power at circuit breaker or fuse.
  - Press pad until locator light is OFF. Lights should turn ON.
- If lights do not turn ON, refer to the TROUBLESHOOTING section.**

## Step 7 Switch Mounting: TURN OFF POWER AT CIRCUIT BREAKER OR FUSE.

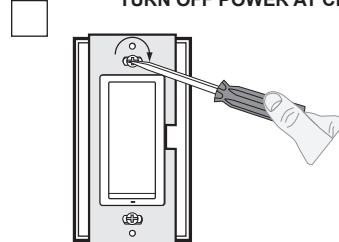

Installation may now be completed by tightening mounting screws into wall box. Attach wallplate.

## Step 8 Restore Power:

Restore power at circuit breaker or fuse.  
**Installation is complete.**

## Operation

**NOTE:** The locator light will illuminate when the load is in the OFF position to facilitate access in the dark.

**Charge time:** 2-4 minutes depending on strength of light source

**Occupancy Sensor minimum light requirement:** 40 LUX

Min 25W (No neutral version)

**Auto ON:** will function with (3) AAA batteries indefinitely when ambient light is present in the room for more than 30 minutes per day.

### Push Pad (Default settings)

**Turn ON from OFF position:**

Tap – Lights turn ON.

**Turn OFF from ON position:**

Tap – Lights turn OFF.

**Cleaning:** Clean with a damp cloth. **DO NOT** use chemical cleaners.

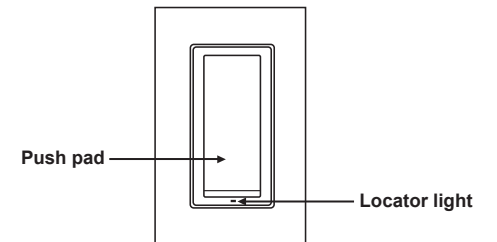

## Troubleshooting

- **Lights Flickering**
  - Lamp has a bad connection.
  - Wires not secured firmly under terminal screws of switch and/or remote.
- **Light does not turn ON and Locator LED does not turn ON**
  - Circuit breaker or fuse has tripped.
  - Lamp is burned out.
  - Lamp Neutral connection is not wired.

**For additional information, contact Leviton's Techline at 1-800-959-6004 or visit Leviton's website at www.leviton.com**

Covered by one or more US & Foreign Patents and patents pending  
All Rights Including Trade Dress Rights Reserved

## FCC COMPLIANCE STATEMENT

This device complies with part 15 of the FCC rules. Operation is subject to the following two conditions: (1) This device may not cause harmful interference, and (2) this device must accept any interference received, including interference that may cause undesired operation. Any changes or modifications not expressly approved by Leviton could void the user's authority to operate this equipment.

© 2009 Leviton Mfg Co., Inc.

PK-93364-10-00-0B

## LIMITED 5 YEAR WARRANTY AND EXCLUSIONS

Leviton warrants to the original consumer purchaser and not for the benefit of anyone else that this product at the time of its sale by Leviton is free of defects in materials and workmanship under normal and proper use for five years from the purchase date. Leviton's only obligation is to correct such defects by repair or replacement, at its option, if within such five year period the product is returned prepaid, with proof of purchase date, and a description of the problem to **Leviton Manufacturing Co., Inc., Attn: Quality Assurance Department, 201 North Service Road, Melville, New York 11747**. This warranty excludes and there is disclaimed liability for labor for removal of this product or reinstallation. This warranty is void if this product is installed improperly or in an improper environment, overloaded, misused, opened, abused, or altered in any manner, or is not used under normal operating conditions or not in accordance with any labels or instructions. **There are no other or implied warranties of any kind, including merchantability and fitness for a particular purpose**, but if any implied warranty is required by the applicable jurisdiction, the duration of any such implied warranty, including merchantability and fitness for a particular purpose, is limited to five years. **Leviton is not liable for incidental, indirect, special, or consequential damages, including without limitation, damage to, or loss of use of, any equipment, lost sales or profits or delay or failure to perform this warranty obligation.** The remedies provided herein are the exclusive remedies under this warranty, whether based on contract, tort or otherwise.