

WARNINGS AND CAUTIONS:

- TO BE INSTALLED AND/OR USED IN ACCORDANCE WITH ELECTRICAL CODES AND REGULATIONS.
- YOU ARE NOT SURE ABOUT ANY PART OF THESE INSTRUCTIONS, CONSULT AN ELECTRICIAN.
- FOR INDOOR USE ONLY.

DESCRIPTION:

The wall-mounted Occupancy Sensor saves energy and adds convenience by accurately detecting when an area is occupied or vacant. It is wireless, solar-powered, and uses a passive infrared (PIR) sensor to detect motion. The occupancy sensor transmits RF signals that control lighting, HVAC and outlets to manage building energy consumption more efficiently.

- Sends wireless signals to receiving devices whenever motion is detected.
- Harvests indoor light to power the sensor and wireless communications.
- Mounts flush on the wall or in a corner; adjustable ceiling corner bracket sold separately.
- Works with other sensors for enhanced occupancy tracking.
- Interchangeable lenses for tailored sensor coverage.
- Built-in tests to confirm operation at installed location.
- Supplemental battery or alternative power supply options for extreme low-light conditions.

If occupation is detected by the permanently active PIR sensor, a radio telegram indicating the occupied status will transmit immediately. An internal timer starts to run with a variable timer length. The timer value may vary between 110 and 130 seconds, depending on the light level. No radio telegrams will be sent out when the timer is counting down.

After the timer has finished the countdown, the unit will transmit again if occupancy is detected after the countdown time period has expired. If occupancy was not detected, the unit will transmit a heartbeat signal - sending the unoccupied status at 10 and 30 minutes. There are two buttons which allow entrance to a "Walk" or "Light-level" test mode. These test modes are for installation purposes only and will be exited automatically after 3 minutes.

PLANNING:

Take a moment to plan for the sensor's successful operation and optimal communication with other system components. Remove the sensor from its packaging and place it under a bright light to provide the required startup charge. To quickly ensure the sensor energy storage is fully charged, insert a CR2032 battery for 5 minutes.

- Ensure the location provides consistent and adequate light.
- Install with the appropriate lens for the required coverage.
- Locate the sensor between 8 and 10 ft (2.4 to 3 m) high with an unobstructed view of the space.
- For wide angle coverage, locate the sensor where traffic moves across the detection pattern, not in and out.
- Consider the area's traffic patterns and principal use, for example, walking, lounging or sleeping.
- Provide a minimum clearance of 4 ft. (1.2 m) away from heat sources, light bulbs, forced air, or ventilation systems.
- Consider the construction materials (such as metal) in the space and obstacles that may interfere with RF signals.

COMPATIBLE DEVICES:

This product is compatible with LevNet RF Advanced Wireless Wall Switches only. Reference the following catalog numbers:

- WSS20-GUZ • WSS20-G9N • WSS20-N9N
- WSS20-G9U • WSS20-N9U

NOTE: This product will not work with LevNet RF Basic Wireless Wall Switches.

EQUIPMENT REQUIRED:

- Power drill, 3/16" bit
- Screwdriver
- Leveling tool
- Light meter
- Battery (CR2032) for testing

INSTALLATION:

The mounting plate can be installed flush to the wall or angled in a corner.

NOTE: It may be easier to associate the sensor before it is mounted on the wall. See the Programming and Activation section.

1. Remove the mounting plate from the sensor assembly by pressing the release tab located on the top of the sensor.
2. Using a level and a pencil, lightly mark two small dots to align the upper edge of the mounting plate
3. Decide which of the two installation options is appropriate:

Flush to the Wall

- Orient the mounting plate using the pencil marks. Mark the two mounting screw drill points.
- Drill two holes with a 3/16" drill bit and insert the wall anchors.
- Insert the first screw loosely and level the mounting plate (see FIGURE 1).
- Insert the second screw then hand-tighten the first screw.

Angled in a Corner

- Orient the mounting plate using the pencil marks.
- Carefully drill through two of the four blind holes on the angled sides of the mounting plate (one on each side).
- Mark the two mounting screw drill points and drill two pilot holes with a 3/16" drill bit and insert the wall anchors.
- Insert the two screws and hand-tighten them (see FIGURE 2).

4. Fit the sensor into the groove at the bottom of the mounting plate and close the top (see FIGURE 3). The sensor snaps into the tab at the top (see FIGURE 4).
5. Confirm the sensor is properly positioned to detect motion and has sufficient light to operate, see the Walk Test and Light Test sections.

PROGRAMMING AND ACTIVATION:

Two or more compatible devices can be linked and configured to provide the desired control. There are two basic types of devices in the system; transmitters and transceivers.

- **Transmit-only:** Transmitters are simple energy-harvesting devices that send RF messages to communicate a condition, level, or state. Transmitters can only be linked to transceivers. Examples > Self-powered Light Switches, Occupancy Sensors
- **Transmit & Receive:** Transceivers are controlling devices that send as well as receive RF messages. They also process relevant control logic, and actuate the appropriate outputs (switching a light on or off for example). Transceivers can be associated with transmitters as well as other transceivers. A transceiver can have up to 30 devices associated to it. Examples > Relays, Gateways

The Occupancy Sensor is a Transmit-only Device. To associate the occupancy sensor to a transceiver; the transceiver must first be powered, within wireless range, and set to accept associations.

Next, the desired transmitter, or another transceiver, is triggered to send a special association/programming message. The awaiting transceiver receives and stores the association permanently so the devices can interact to provide a variety of intelligent control options.

To associate or disassociate an Occupancy Sensor:

1. Set the desired transceiver to accept an association (refer to that device's installation guide).
2. Click the Menu button on the bottom of the sensor once. This sends a associate/disassociate radio telegram (see FIGURE 5). **NOTE:** The button interface on the sensor is used for associating and testing only. The occupancy timer settings are configured on the transceiver to which the sensor is associated.

Refer to the "Programming and Activation" section of the transceiver/controller installation guides to complete the linking process.

TESTING:

Before starting a test, ensure the sensor's energy storage is fully charged by placing it under bright light (at least 200 lux) for 20 minutes, or insert a battery for 5 minutes.

If a battery is used to charge the sensor for a light test, ensure it is removed to get an accurate light measurement.

A test mode will stay active for 3 minutes. To exit a test and resume normal operation, press and hold the Menu button for 5 seconds.

Walk Test

Use the walk test to confirm that motion is within the sensor's range.

1. Press and hold the Set button for 5 seconds.
 - Red LED will blink to confirm that a walk test is active.
2. Move in and out of the sensor's range to determine its coverage area.
 - Sensor will blink when it detects motion.
3. Make small hand movements just inside the limit of the sensor's range to see if the motion triggers a response.

Light Test

Use the light test to measure real-time light levels and confirm whether the occupancy sensor has sufficient light.

1. Create a realistic lighting condition (the test measures the real-time light level).
2. Press and hold the Set button for 10 seconds.
 - Red & green LEDs will blink to confirm light test is active.
3. Watch the LED blink rate to determine the light strength.
 - The highest is 5 blinks which indicates very good light. 1 blink indicates minimum light.

NOTE: If there is no blink rate, consider relocating the sensor or installing a battery to provide supplemental power. If the sensor does not have a sufficient charge, it cannot enter the test modes. No LED light or 1 red blink when the set button is pressed indicates insufficient charge.

CHANGING THE LENS:

The Occupancy Sensor package contains two lenses: a wide angle lens and a long range lens. The wide angle lens is installed by default and can be distinguished from the long range lens by the pattern. To change the lens:

1. If the sensor is mounted, press the top tab and remove it from the mounting plate.
2. Unscrew the front cover screw on the back at the bottom and remove the front cover (see FIGURE 6).
3. Remove the installed lens by gently squeezing it to ease one side out of its groove, and then the other (see FIGURE 7).
4. Insert the lens you want to use by aligning the notch with the top on the front cover. Orient the smooth side facing out, and the textured side facing the sensor.
5. Hold both edges of the lens, flex it gently and push until it pops into the grooves. Make sure the edges are flush. **NOTE:** If the lens is out of position, the sensor will not detect activity properly.
6. Replace the top edge of the front cover and then close it on the sensor (see FIGURE 8).
7. Replace the bottom screw and remount sensor on the plate.

INSTALLING SUPPLEMENTAL BATTERY (OPTIONAL):

If light levels are very low where the sensor is installed, auxiliary battery power (CR2032) can be used to supplement the solar energy harvester.

1. Remove the sensor from the mounting plate.
2. Unsnap sensor cover and identify the battery holder on the circuit board.
3. Insert the battery under the clip with the positive pole (+) up and press it in place (see FIGURE 9).
4. Replace cover and remount the sensor on the wall.

TROUBLESHOOTING:

Sensor does not generate a wireless message:

- Verify the LED blinks when motion is detected during a walk test.
- Verify the solar cell is charged properly.

Sensor is activated when there is nothing to detect:

- Verify there is 4 ft. (1.2 m) clearance from heat sources that may disturb sensing.
- Reduce sensitivity setting by moving the PIR sensitivity switch on the back to low (the left-hand position).

Linked device does not respond to wireless messages:

- Check for environment or range issues.
- Verify the device is linked.
- Check the transceiver connection and the wiring for errors.
- Check if appropriate devices are linked according to good system planning.

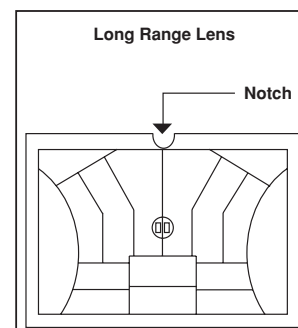
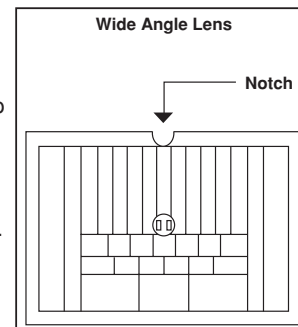

SPECIFICATIONS	
Cat. No. WSWDR-H9W	
Field of View	Wide Angle = 2000 sq. feet Long Range = 1600 sq. feet
Frequency / Range	902 MHz / 50-150 feet
Power Supply	Solar Powered, Battery for backup (optional)
Light Required to Sustain Operation	50 lux for 30 transmissions per hour
Charge Time for Full Charge	3 Hours @ 200 lux (after startup) 6 Hours @ 200 lux (cold Start)
Environmental	Indoor Use Only 14° to 104°F (-10° to 40°C) 20% to 95% relative humidity (non-condensing)
Charge Time before Linking	4 Minutes @ 100 lux
Radio Certification	FCC (United States) SZV-STM300U I.C. (Canada) 5713A-STM300U

DIMENSIONS	
Solar Cell	2.5" (64mm)
Lens	5.8" (148mm)
Button Interface	1.1" (28mm)
	1.8" (45.7mm)

FIGURES

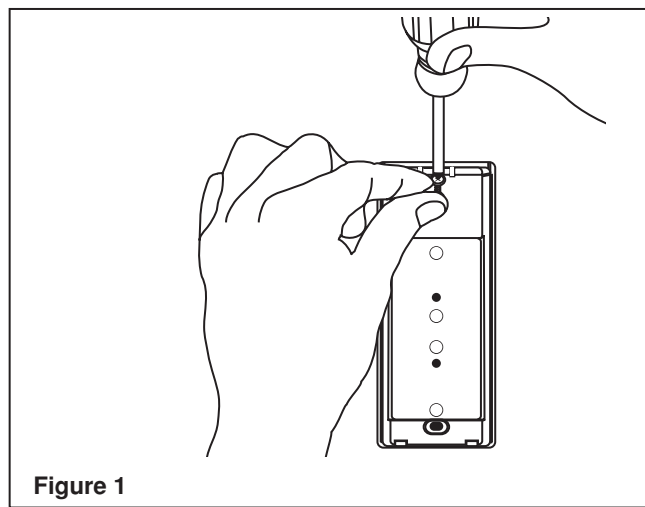

Figure 1

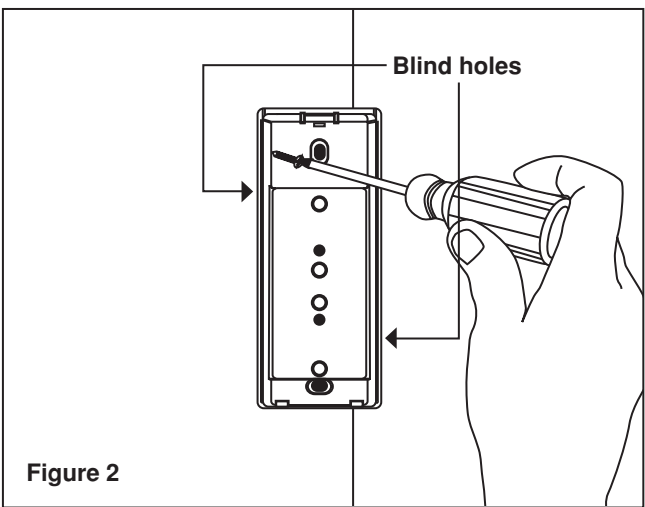

Figure 2

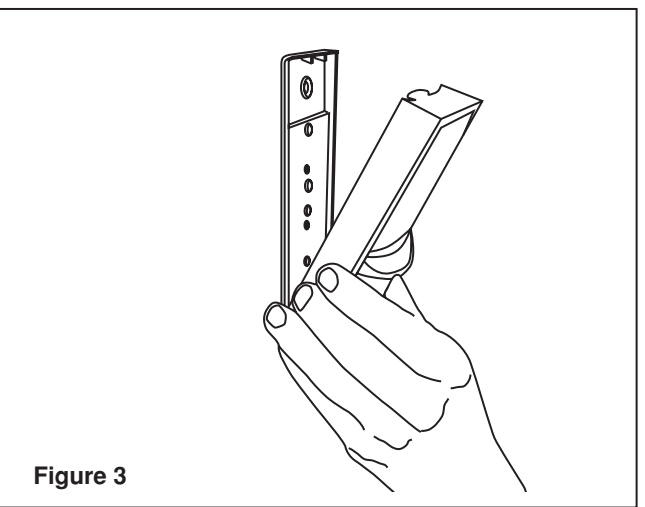

Figure 3

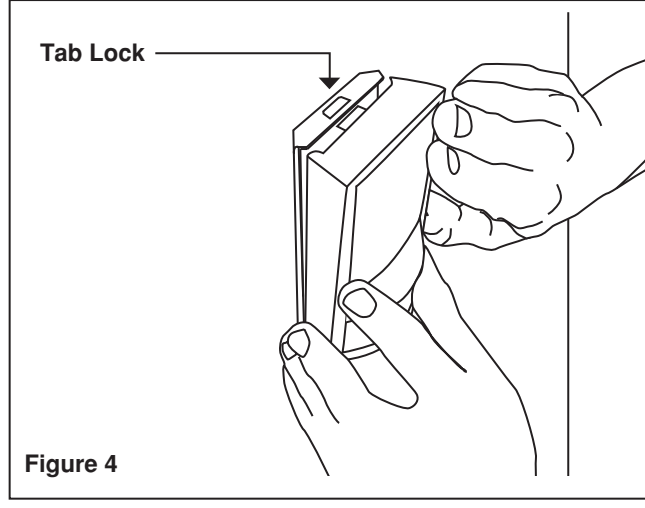

Figure 4

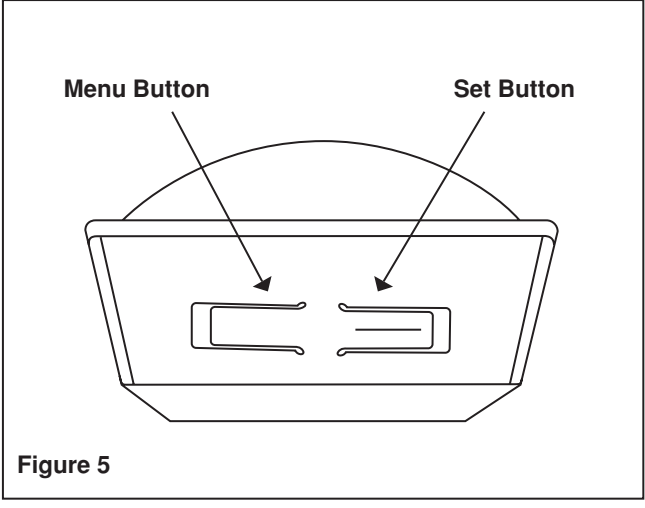

Figure 5

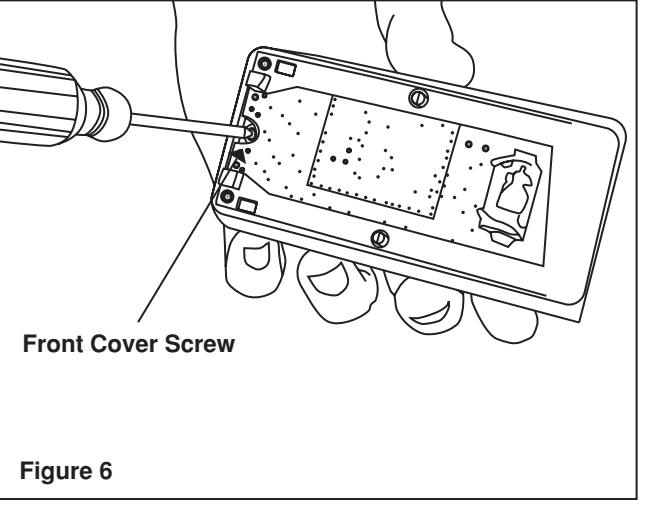

Figure 6

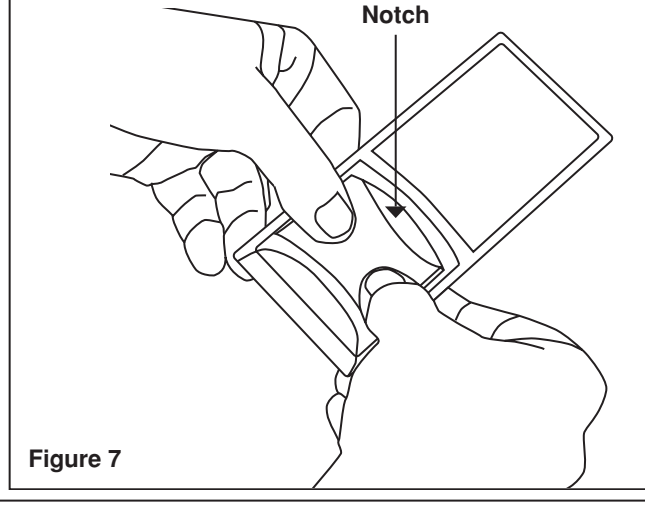

Figure 7

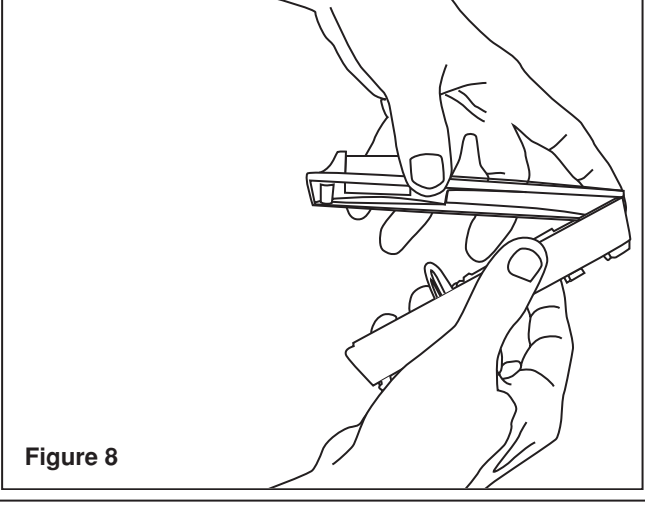

Figure 8

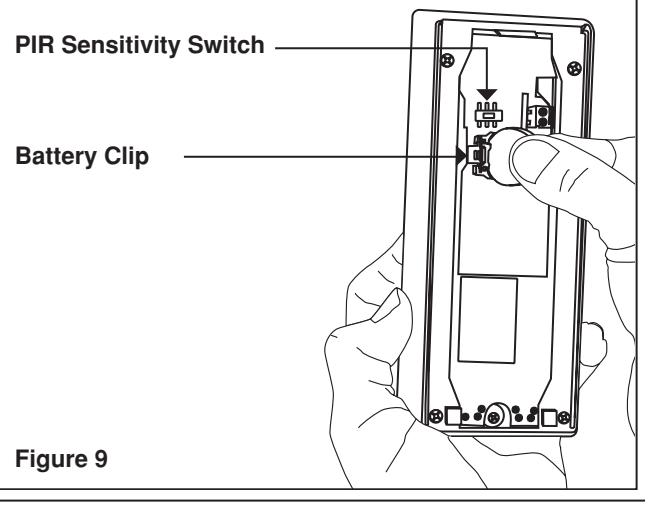
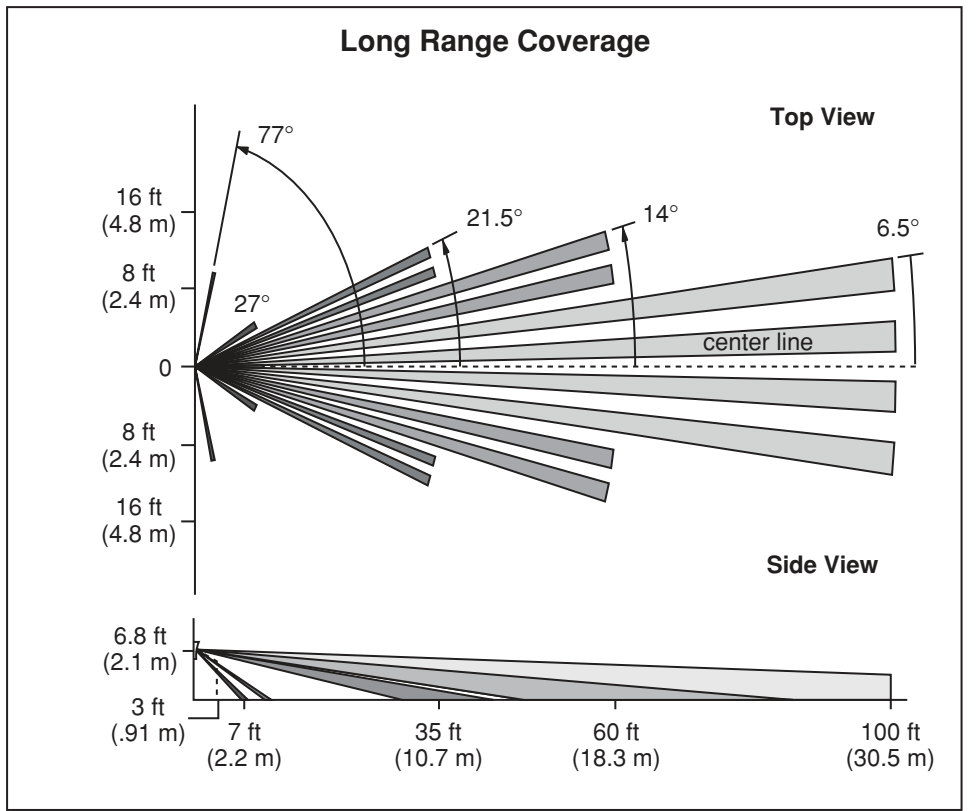
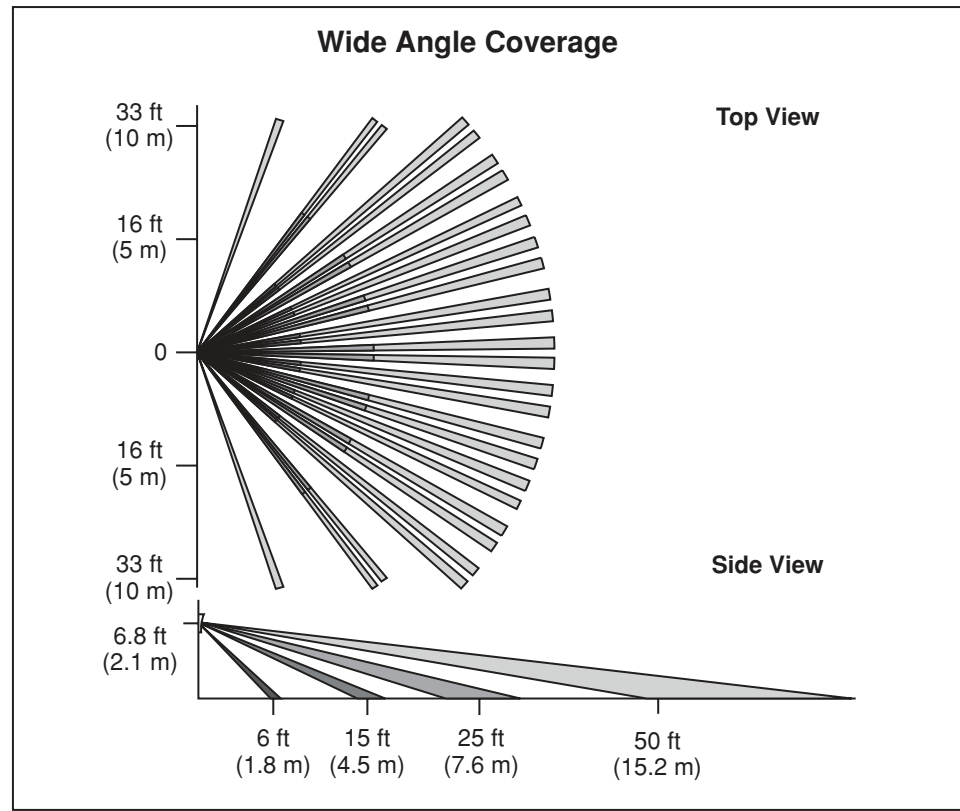

Figure 9

SENSOR RANGE



Note: A single occupancy sensor provides sufficient coverage for most applications. For some applications, multiple sensors may be required to provide complete coverage.

FCC COMPLIANCE STATEMENT:

FCC ID: SZV-STM300U IC: 5713A-STM300U
 The enclosed device complies with Part 15 of the FCC Rules.
 Operation is subject to the following two conditions:
 (i.) This device may not cause harmful interference
 (ii.) This device must accept any interference received, including interference that may cause undesired operation.
 Any changes or modifications not expressly approved by Leviton could void the user's authority to operate this equipment.

Leviton is a registered trademark of Leviton Mfg. Co. in the United States, Canada, Mexico, and other countries. Other trademarks herein are the property of their respective owners.

These products are covered by one or more U.S. & Foreign Patents and Patents Pending
 Copyright © 2013 Leviton Manufacturing Co., Inc.
 All rights Including Trade Dress Rights Reserved

LIMITED 2 YEAR WARRANTY AND EXCLUSIONS

Leviton warrants to the original consumer purchaser and not for the benefit of anyone else that this product at the time of its sale by Leviton is free of defects in materials and workmanship under normal and proper use for two years from the purchase date. Leviton's only obligation is to correct such defects by repair or replacement, at its option. This warranty excludes and there is disclaimed liability for labor for removal of this product or reinstallation. This warranty is void if this product is installed improperly or in an improper environment, overloaded, misused, opened, abused, or altered in any manner, or is not used under normal operating conditions or not in accordance with any labels or instructions. **There are no other or implied warranties of any kind, including merchantability and fitness for a particular purpose, but if any implied warranty is required by the applicable jurisdiction, the duration of any such implied warranty, including merchantability and fitness for a particular purpose, is limited to two years. Leviton is not liable for incidental, indirect, special, or consequential damages, including without limitation, damage to, or loss of use of, any equipment, lost sales or profits or delay or failure to perform this warranty obligation.** The remedies provided herein are the exclusive remedies under this warranty, whether based on contract, tort or otherwise.

FOR CANADA ONLY