

**SAVE THESE INSTRUCTIONS!**  
**READ CAREFULLY AND FOLLOW ALL INSTRUCTIONS FOR YOUR OWN SAFETY**

- DISCONNECT AC POWER SUPPLY BEFORE SERVICING.
- Installation and servicing of this equipment should be performed by qualified service personnel only.
- Ensure the electricity connections conform to the National Electrical Code and local regulations if applicable.
- Do not mount near gas or electrical heaters.
- Equipment should be mounted in locations and at heights where it will not readily be subjected to tampering by unauthorized personnel.
- The use of accessory equipment not recommended by the manufacturer may cause an unsafe condition. Any modification or use of non-original components will void the warranty and product liability.
- Do not use this equipment for other than intended use.



## INSTALLATION INSTRUCTIONS

### Surface Mount

1. Remove end cap by loosening (2) Flat head screws. (Fig. 1)
2. Remove homeplate assembly from enclosure by sliding out. (Fig. 1)
3. Install backplate to enclosure using (2) 6-32 screws, washers and nuts. (Fig. 2)

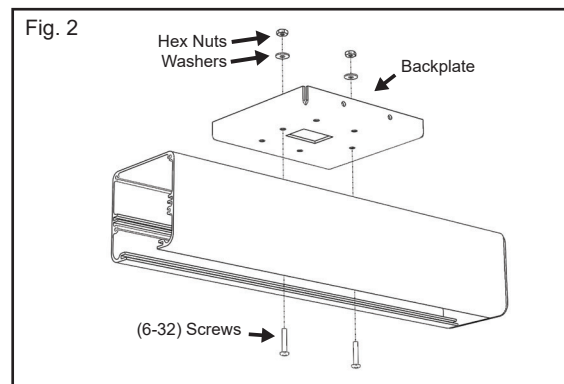
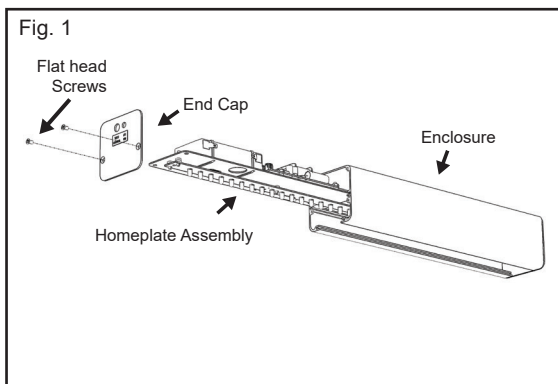

Transformer Board Switch Setting and Location

**Warning:** LED light strip(s) must be connected to transformer board before applying power to sign.

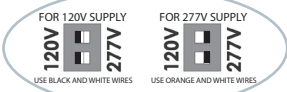

DIP Switch Preset For 277 V AC  
Follow these guidelines before  
applying power to the circuit  
board.

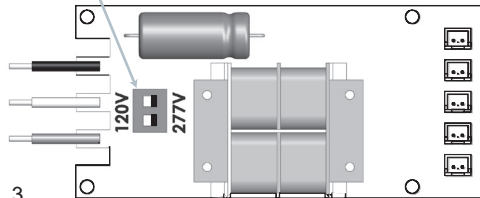

Fig. 3

Fig. 4

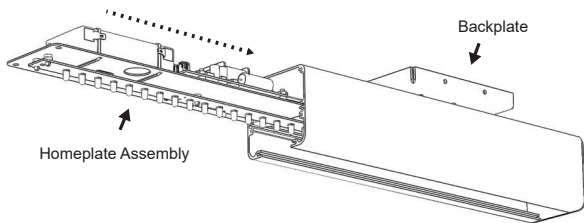
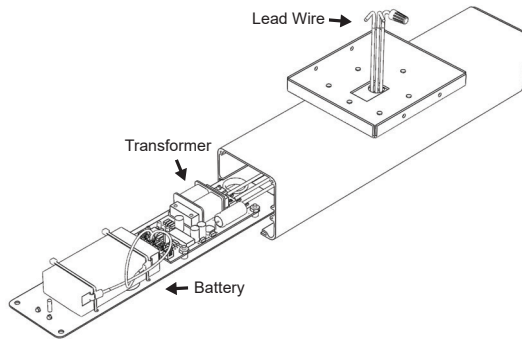
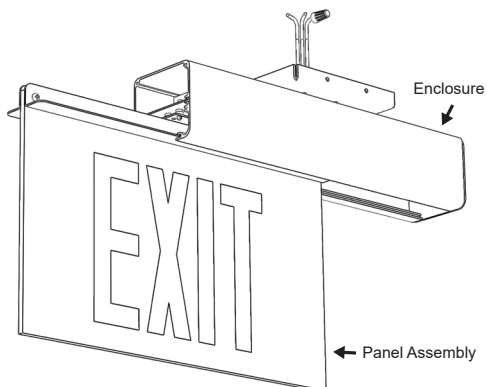

Fig. 5

Fig. 6



4. Leads for AC connection to be pulled out of desired mounting hole. (Fig. 4)

5. Adjust dip switch on unit for desired voltage. (Fig. 3)

**Note:** Battery supplied with units should be connected prior to installing homeplate.

- Red lead to positive (+) terminal
- Black lead to negative (-) terminal

6. Slide homeplate back into enclosure. (Fig. 5)

7. Slide panel assembly into enclosure. (Fig. 6)

8. Mount test button and LED indication to end cap. (Fig. 7)

9. Reinstall end cap. (Fig. 8)

Fig. 7

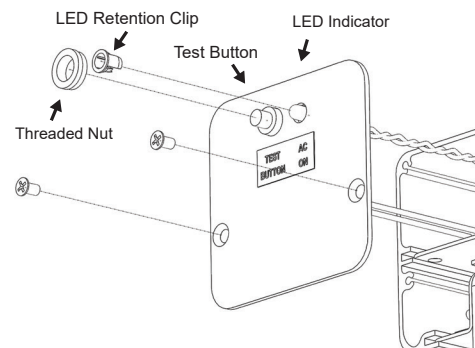
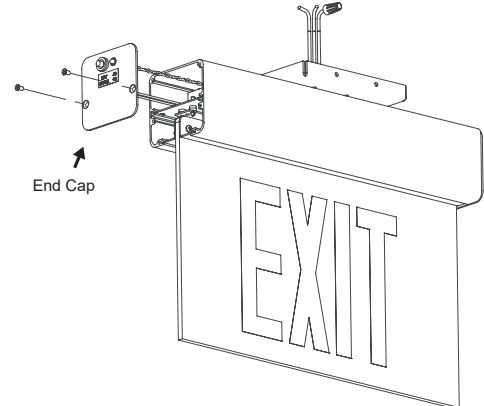

Fig. 8



10. Install 7/8" bushing into opening in mounting plate. (Fig. 7)
11. Install mounting plate to junction box using field supplied screws. (Fig. 8)
12. All Electrical connections should be made inside junction box. (Fig. 8)

Make Electrical Connection as follows:

120V AC	220/230V AC	277V AC
White - Common	White - Common	White - Common
Black - 120V	Yellow - 220/230V	Orange - 277V
Green - Ground	Green - Ground	Green - Ground

**Note:** Cap unused leads to prevent shorting.

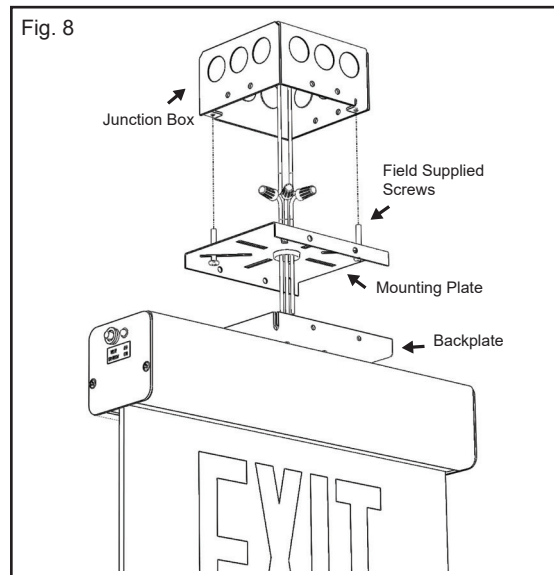
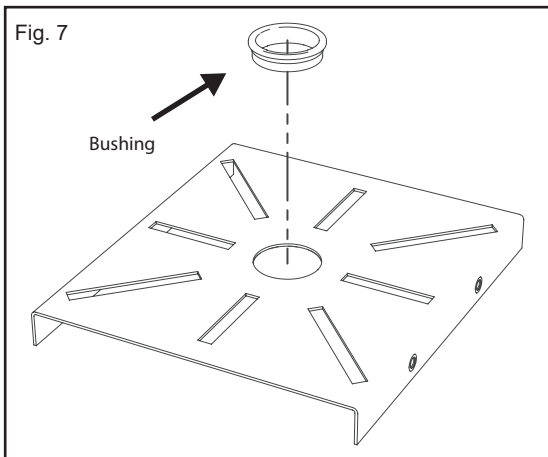

13. Secure backplate to mounting plate with (4) 6-32 x1/4 screws. (Fig. 9)

14. Figures 1-9 for ceiling surface mount. Follow the same steps for wall mount (Fig 10)

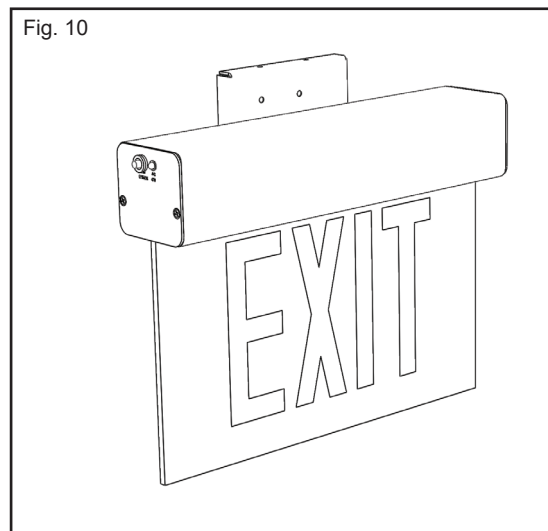
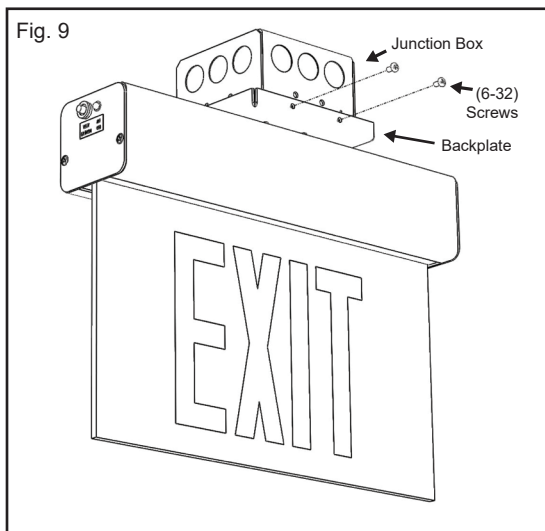

**Recessed**

1. Remove homeplate from recessed box by loosening (2) 6-32 screws and set aside. (Fig. 1)
2. Cut opening in wall or ceiling to accept 3"x15" box. Keeping below the trimplate dimensions of 3' 7/8".
3. Punch out desired knockouts on recessed box.
4. Install hanger bars to the correct sides of recessed box using 6-32 screws. (Fig. 1)
5. Pull wires through knockout holes and connect to homeplate then install homeplate to recessed box by tightening (4) 6-32 screws.
  - If Ceiling mounting; position recessed assembly and bar hangers between joists making sure bar hangers (t-bars) are positioned correctly. Using adjusting slots to guide, bar hanger should be level with the bottom of the joist. (Fig. 2)
  - If Wall mounting; position recessed assembly inside wall and fasten with L-Brackets to wall using screws and anchors (not provided). (Fig. 3)

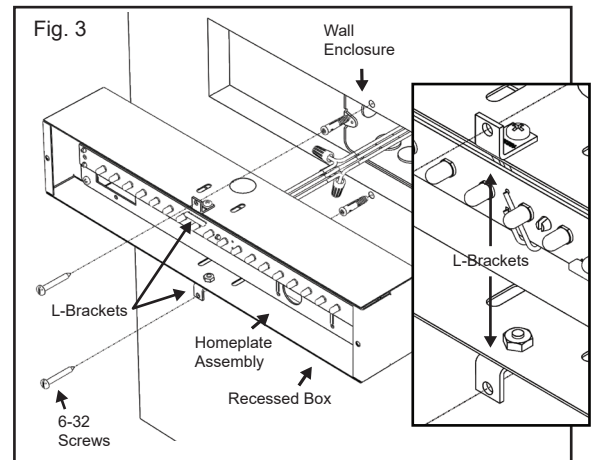
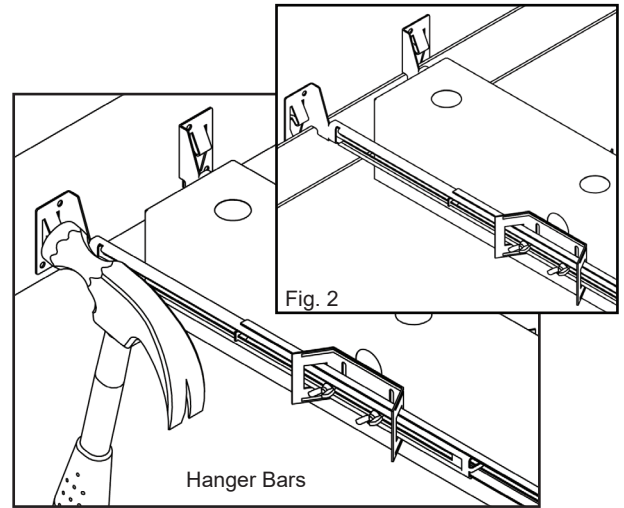
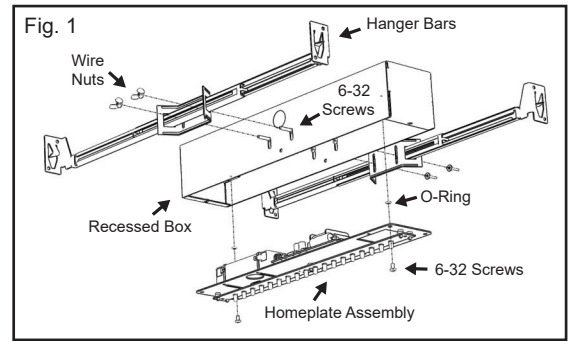

6. Slide trimplate onto panel to proper position for installation. (Fig. 4)

7. Install test button and LED indicator to trimplate. (Fig. 5)

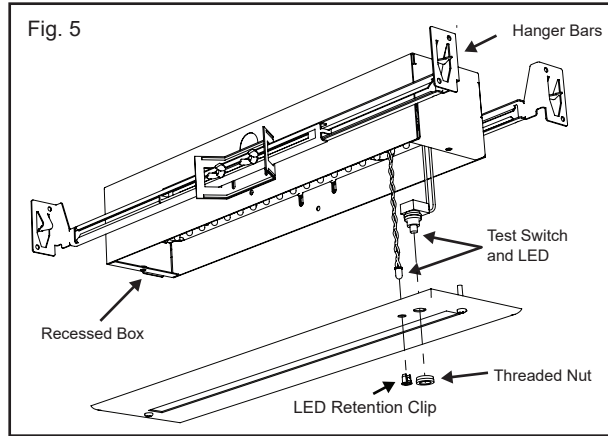
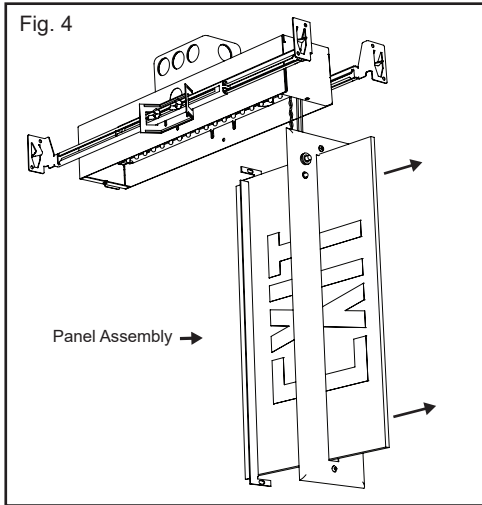

8. Position trimplate/panel assembly to recessed box.

Align center of trimplate with LED strip and secure with (2) 6-32 X 3/4 screws. (Fig. 6) (6b Wall Recessed)

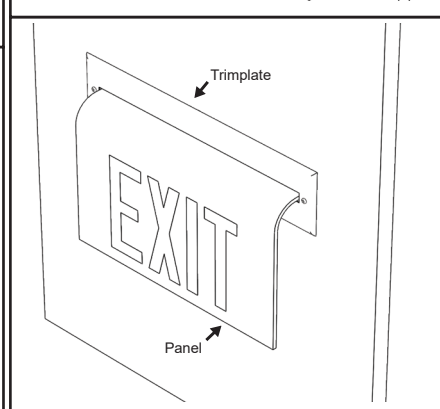
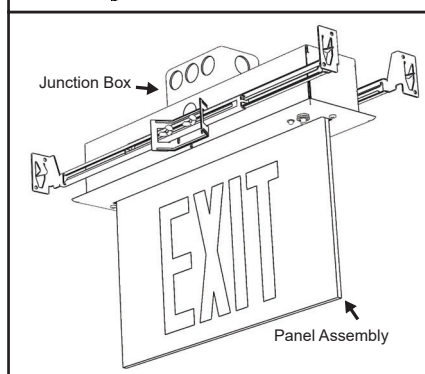
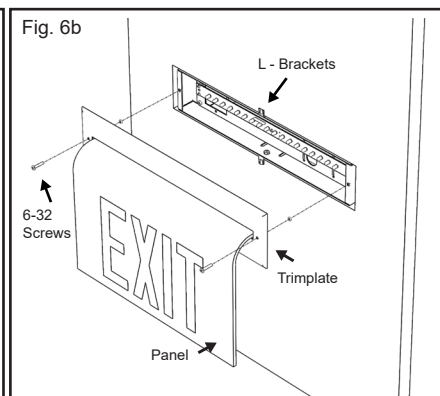
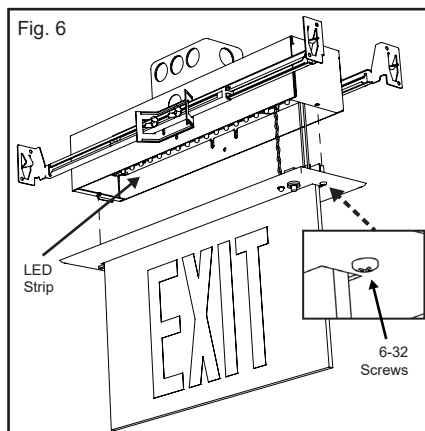

\*\* Units equipped with self-diagnostic/self-testing features do not require DIP switch adjustment. \*\*

**SELF-TEST AND SELF-DIAGNOSTIC (Option)**

**OPERATION**

The purpose of this option is to provide self-testing and self-diagnostic capabilities to the EXIT sign. At predetermined intervals, the EXIT sign will automatically switch into battery mode. Refer to the Self-Test section of this page for timing details. The EXIT sign will also perform various self-diagnostic tests of the unit. Visual signaling will alert maintenance personnel to a fault of the EXIT sign electronics, battery and/or battery charger. The circuitry continuously monitors the operating condition of the EXIT sign and battery charging circuit/battery supply voltage. Refer to Self-Diagnostic section of this page for fault reporting details.

**LEDs**

The EXIT sign is provided with a state-of-the art pulse charging system for the battery. The yellow LED (STEADY STATE) indicates that the charger is turned off. The red LED (CHARGER ON) indicates that the battery is under full charge. NOTE – the “STEADY STATE” and “CHARGER ON” LEDs will toggle faster with a discharged battery. A fully charged battery will cause the “STEADY STATE” LED to be illuminated longer than the “CHARGER ON” LED. The green “AC ON” LED indicates that normal AC power is being supplied to the EXIT sign. The red “UNIT ALERT” indicates whenever the self-diagnostic system has detected a fault condition. An audible alert will sound on units provided with an audible alarm (option “AA”) whenever the self-diagnostic system has detected a fault condition.

**SELF-TEST FEATURES**

The EXIT sign will automatically switch to battery mode every 28 days for a period of 5 minutes OR every 6 months for a period of 90 minutes.

**Test Button Features**

- Pressing the “TEST BUTTON” once will switch the unit into battery mode for a period of 2 seconds.
- MANUAL TEST - Pressing the “TEST BUTTON” twice (in rapid succession), will switch the unit to battery mode for a period of 15 minutes. Pressing the “TEST BUTTON” once while the unit is MANUAL TEST mode will cancel the manual test and return to unit to normal AC power.
- RESET – Pressing the “TEST BUTTON” 3 times will reset the red “UNIT ALERT” LED. If multiple faults are present, it may be necessary to repeat this procedure for each remaining fault indicated by the “UNIT ALERT” LED.
- On units provided with an audible alarm (option “AA”), pressing and holding the “TEST BUTTON” for 5 seconds will disable the alarm for 24 hours.

**Self-Diagnostic Features**

Refer to the chart below when the “UNIT ALERT” LED is blinking.

Number of Blinks	Unit Fault	Corrective Action
1	Battery is Disconnected	Check battery connections
2	Battery	Replace battery
3	Not Applicable	Not Applicable
4	Charger	Check battery then consult factory
5	Transfer (AC to DC )	Check battery then consult factory

Use in accordance with local building codes.