

SPECIFICATIONS

Hurricane™ Centrifugal Inline Fan - 12 Inch

Item #736590

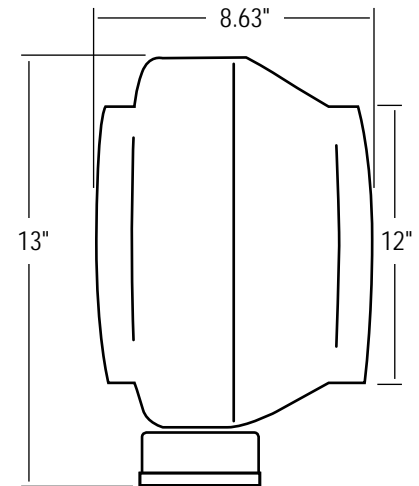

ETL LISTED	Yes
Tested to UL Standard No. 507	
Tested to CSA Standard C22.2 No. 113	
VOLTAGE	120
AMPS	2.5
WATTAGE	300
CFM	1060
RPM	2575
POWER CORD	Integrated 8 ft. - 120 Volt
FAN DIAMETER	12 inch
WEIGHT	16 lbs
WARRANTY	5 year

Hurricane™

This document is not intended to be used for installation purposes. We cannot cover all specific applications or anticipate all requirements. All specifications are subject to change without notice.