

SPECIFICATIONS

Hurricane™ Centrifugal Inline Fan - 6 Inch

Item #736575

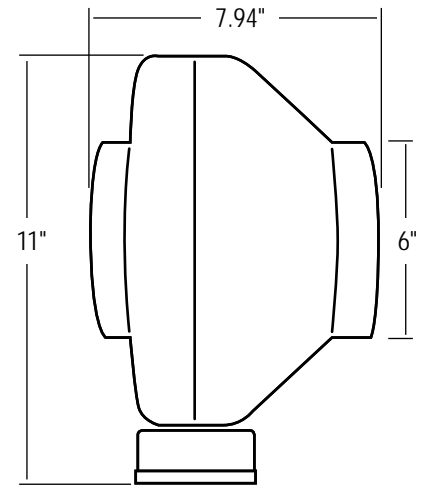

ETL LISTED	Yes
Tested to UL Standard No. 507	
Tested to CSA Standard C22.2 No. 113	
VOLTAGE	120
AMPS	1.0
WATTAGE	115
CFM	435
RPM	2915
POWER CORD	Integrated 8 ft. - 120 Volt
FAN DIAMETER	6 inch
WEIGHT	9 lbs
WARRANTY	5 year



This document is not intended to be used for installation purposes. We cannot cover all specific applications or anticipate all requirements. All specifications are subject to change without notice.