

# SPECIFICATIONS

# Hurricane™ Centrifugal Inline Fan - 4 Inch

Item #736570

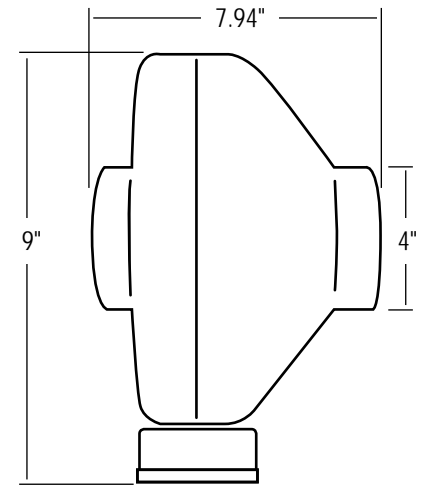

ETL LISTED	Yes
Tested to UL Standard No. 507	
Tested to CSA Standard C22.2 No. 113	
VOLTAGE	120
AMPS	1.0
WATTAGE	113
CFM	171
RPM	2910
POWER CORD	Integrated 8 ft. - 120 Volt
FAN DIAMETER	4 inch
WEIGHT	8 lbs
WARRANTY	5 year

